

GATE ACCESSORIES





25 500 m²

UMAKOV KROMPACHY



Spoločnosť UMAKOV už viac ako 30 rokov vyrába a predáva komponenty pre nerezové a sklenené zábradlia. Spoločnosť má širokú sieť partnerov a pobočiek na Slovensku, v Českej republike, Poľsku a Maďarsku. Má vlastnú produkciu, obchod a administratívu na ploche viac ako 25 000 m². Vysoká kvalita, rýchle doručenie, viac ako 5000 druhov komponentov na sklade a profesionálna technická podpora robí v súčasnosti z UMAKOV-u jedného z lídrov Európskeho trhu v predaji komponentov pre zábradlia. Naše portfólio obsahuje sklenené systémy, prístrešky, schody, brányové príslušenstvo a kované komponenty.



Przez ponad 30 lat firma UMAKOV produkuje i sprzedaje elementy ze stali nierdzewnej oraz skladniki dla balustrad szklanych. Działalność firmy Umakov jest realizowana w ich własnych oddziałach oraz sieciach partnerów na Słowacji, w Czechach, Polsce i na Węgrzech. Firma posiada również własną produkcję, przestrzenie handlowe oraz administracyjne o łącznej powierzchni około 25.000 m². Najwyższa jakość, szybka dostawa, ponad 5000 typów komponentów na magazynie oraz profesjonalne wsparcie techniczne sprawia z firmy UMAKOV jednego z liderów na rynku europejskim w sprzedaży elementów do balustrad nierdzewnych. Nasza oferta obejmuje również systemy szklane, zadaszenia, schody, bramy oraz elementy kute.



Az UMAKOV több, mint 30 éve gyárt és értékesít rozsdamentes acél- és üvegorlát elemeket. Az UMAKOV üzleti tevékenységét saját leányvállalatain és partner hálózatain keresztül gyakorolja Szlovákiában, Csehországban, Lengyelországban és Magyarországon. A cég saját gyártási tevékenysége, kereskedelmi és adminisztratív központja mintegy 25 000 m² alapterületen helyezkedik el. Csúcs minőség, gyors szállítás, több, mint 5000 raktárkészleten lévő termék, valamint professzionális műszaki támogatás teszik az UMAKOV-ot ma Európa egyik vezető vállalatává a korlát elemek területén. Választékunkban megtalálhatók még üveg rendszerek, elötétők, lépcsők, kaputechnika és kovacsoltvas termékek.



For over 30 years UMAKOV has produced and sold components for stainless steel and glass railings. Umakov business activities are carried out in their own branches and network of partners in Slovakia, Czech Republic, Poland and Hungary. Company also owns their own production, commercial and administrative spaces with total area of about 25 000 m². Top quality, fast delivery, over 5000 types of components in stock and professional technical support makes UMAKOV today one of Europe's market leaders in railing components. Our portfolio also includes glass systems, canopies, stairs, gate accessories and forged components.



Firma UMAKOV produziert und verkauft die Komponente für Edelstahl- und Glasgeländer schon länger als 30 Jahren. UMAKOV hat Partnern und Filialen in der Slowakei, in der Tschechischen Republik, in Polen und Ungarn. Das Unternehmen verfügt über eigene Produktion, Geschäft und Betriebsverwaltung auf der Fläche von ca 25 000 m². Hohe Qualität, schnelle Lieferung, mehr als 5000 Arten von Komponenten auf dem Lager und professionelle technische Unterstützung, das alles macht von UMAKOV einer der europäischen Marktführer im Verkauf von Komponenten für Geländer. Unser Portfolio umfasst Glassysteme, Vordachsysteme, Treppen, Tor Zubehör und Schmiedeteile.



Depuis plus de 30 ans UMAKOV produit et vend des composants pour les garde-corps inox et verre. La société UMAKOV dispose d'un réseau de filiales et partenaires en Slovaquie, République Tchèque, Pologne et Hongrie. Elle possède ses propres espaces de production, de vente, au sein de son siège administratif, d'une surface d'environ 25 000 m². Haute qualité, livraison rapide, plus de 5000 types de composants en stock et une assistance technique professionnelle, font aujourd'hui d'UMAKOV un des leaders européens dans le secteur des composants de garde-corps. Notre gamme comprend également des systèmes en verre, auvents, escaliers, accessoires pour portails et pièces forgées.

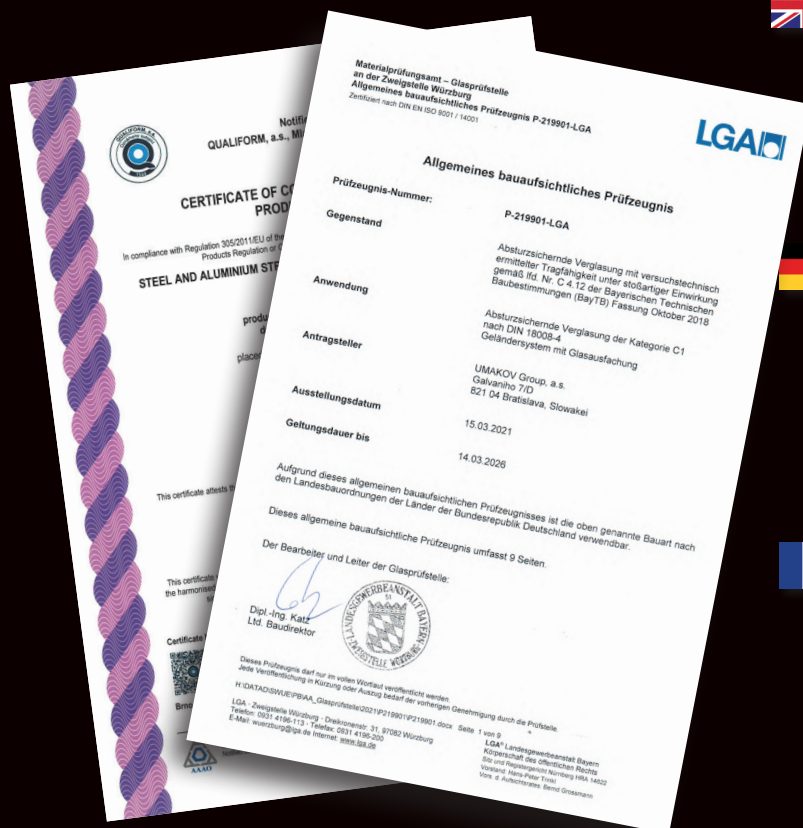



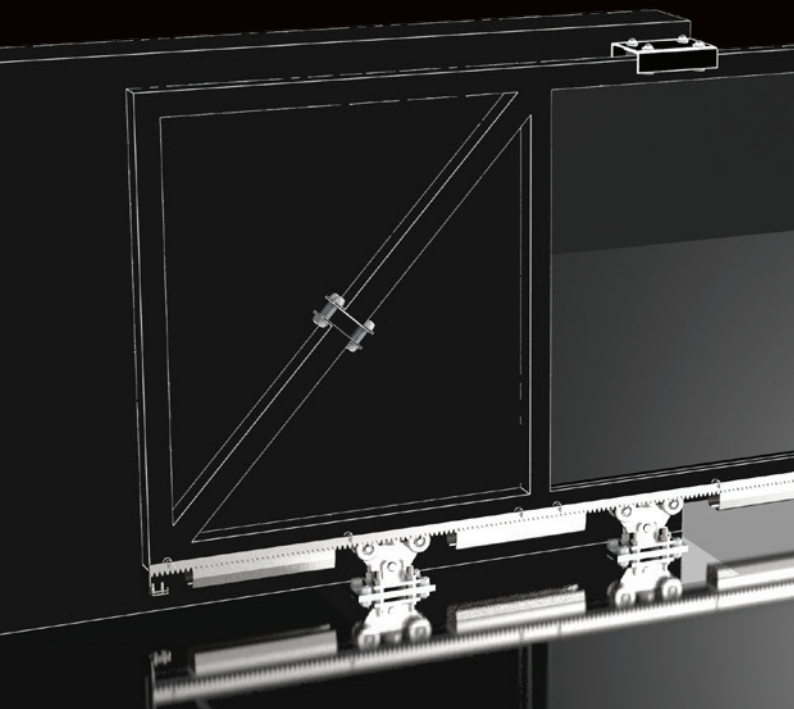

1 POSUVNÉ BRÁNY - SAMONOSNÉ CANTILEVER GATES

4-23

2 POSUVNÉ BRÁNY - KOLIESKOVÉ ROLLING GATES

24-29

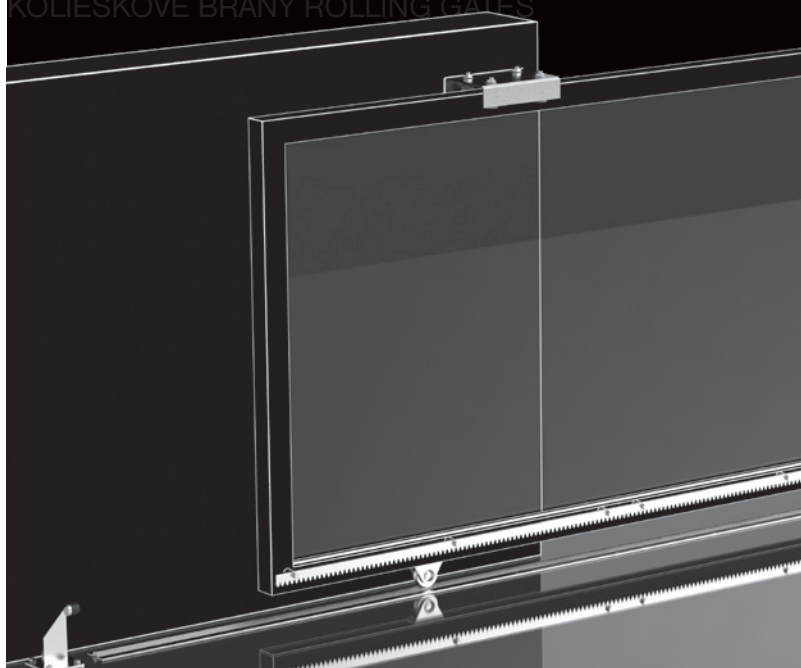

3 POSUVNÉ BRÁNY - PRÍSLUŠENSTVO SLIDING GATES - ACCESORIES

30-51



4 ZÁVESNÉ BRÁNY HANGING GATES

52-59

5 KRÍDLOVÉ BRÁNY SWING GATES

60-123

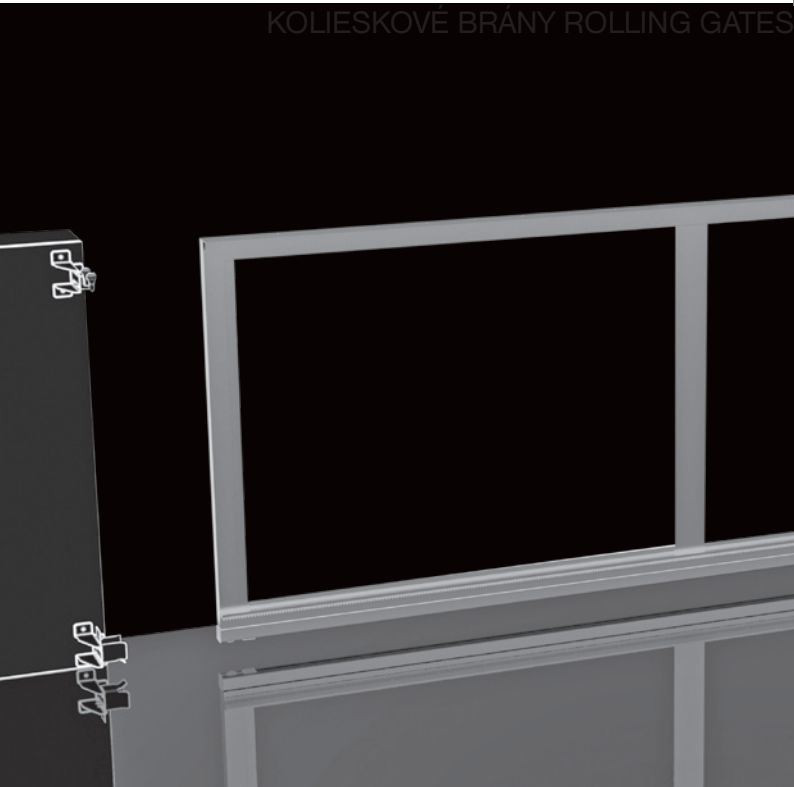
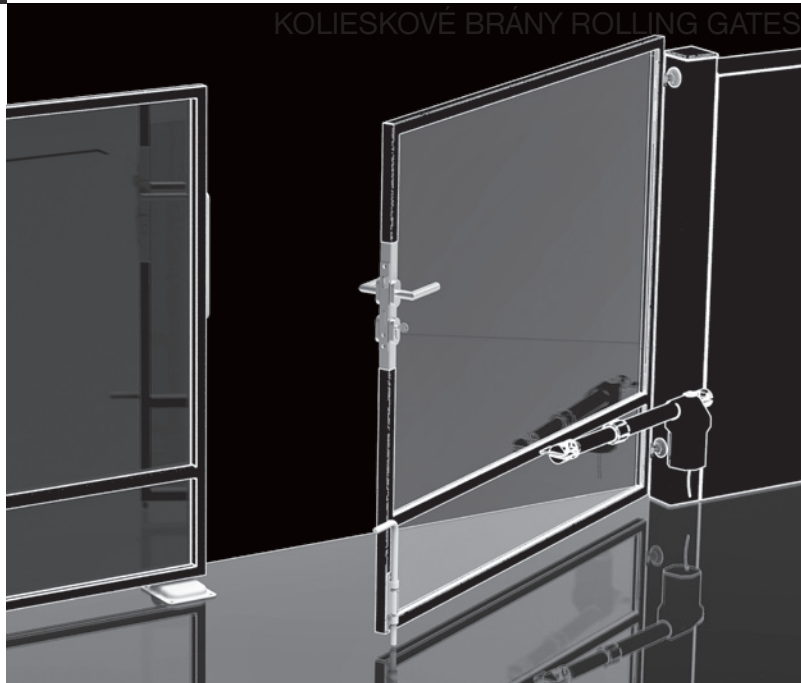

- ## **6**
- **HLINÍKOVÉ BRÁNY**
ALUMINIUM GATES
 - **PRÍSLUŠENSTVO**
ACCESSORIES

124-142

1 POSUVNÉ BRÁNY - SAMONOSNÉ CANTILEVER GATES



SETY
SETS

SETS



PROFILY
PROFILES



VOZÍKY
CARRIAGES



PRÍSLUŠENSTVO
ACCESSORIES

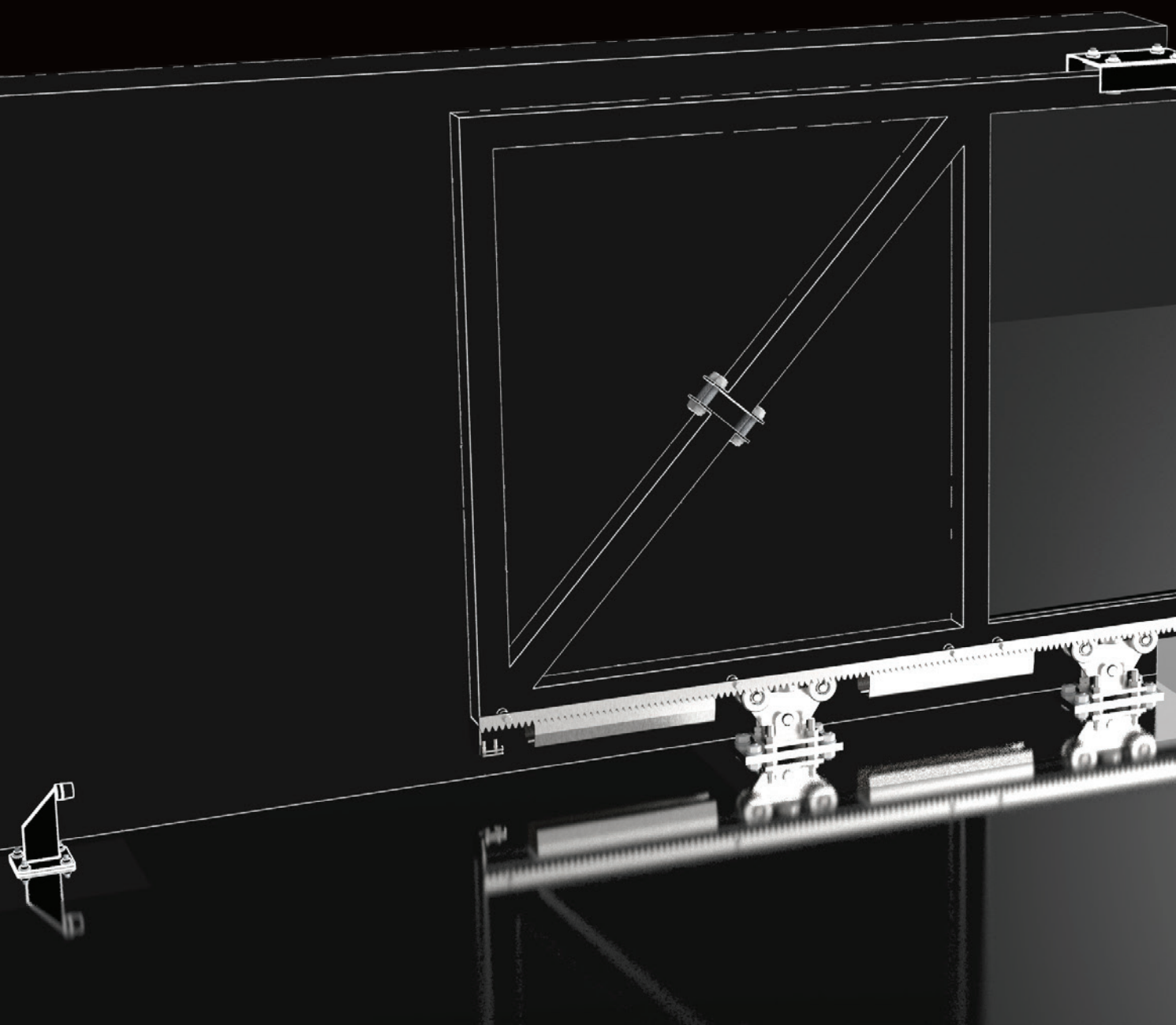

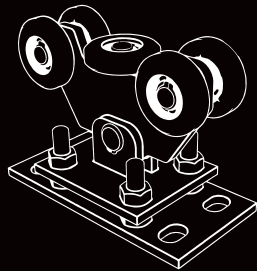
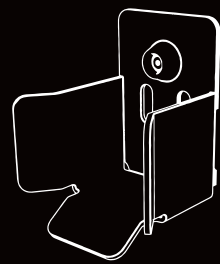
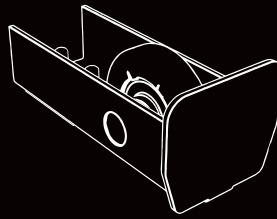
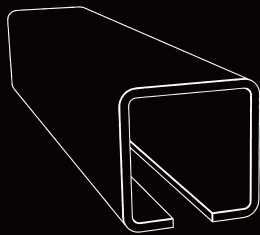

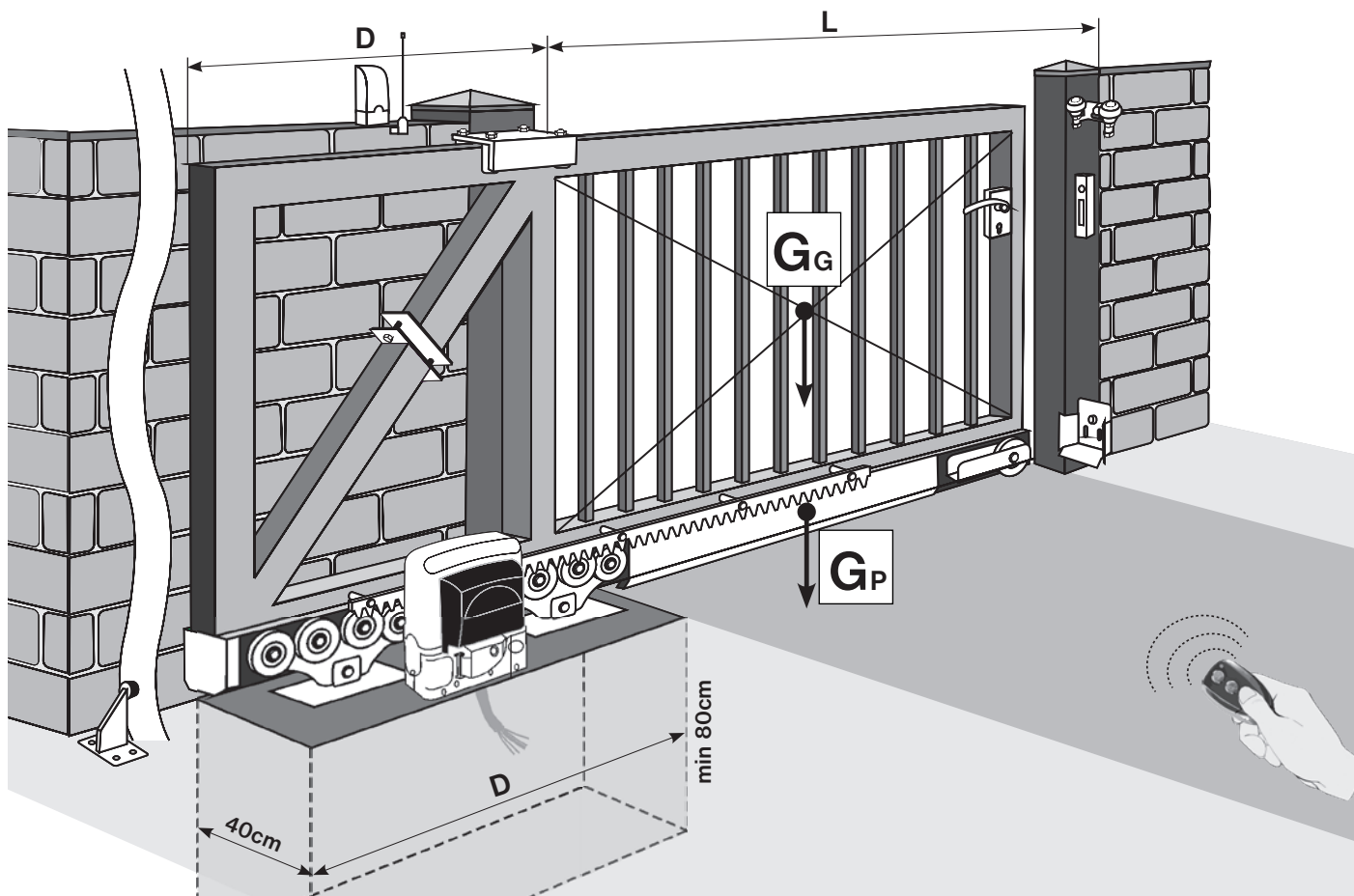







SETS	60x60		70x60		70x70		80x80		90x95 90x99		94x85		136x142	
	L (cm)	G (kg)	L (cm)	G (kg)	L (cm)	G (kg)	L (cm)	G (kg)	L (cm)	G (kg)	L (cm)	G (kg)	L (cm)	G (kg)
SV-60x60 classic-NYLON	300	105	119	77	83	111	84							
SV-60x60Zn classic-NYLON	300	150	156	96	109	138	102							
SV-60x60 inox-classic	350	125	147	91	101	134	97	113	87	100	83	113		
SV-60x60 classic	350	175	212	120	139	168	123	153	99	109	90	153		
SV-60x60Zn classic	400	140	174	107	121	156	111	134	100	110	95	134	107	
SV-70x60 classic	400	200	290	150	177	214	150	196	116	120	105	196	119	132
SV-70x60Zn classic	450	160		129	148	185	131	164	114	120	103	164	119	131
SV-70x70 classic-NYLON	450	225		187	226	277	182	250	135	133	122	250	137	142
SV-70x70Zn classic-NYLON	500	175		151	177	213	151	194	125	122	108	194	129	134
SV-70x70 classic	500	250		232	290	350	221	320	159	146	143	320	157	153
SV-70x70Zn classic	550	200		187	224		180	237	138	135	125	237	139	145
SV-70x70BP classic	550	275		289	370		270	370	186	161	165	370	180	165
SV-70x70BP-Zn classic	600	210		212	256		205	281	151	189	140	281	151	155
SV-80x80 classic-NYLON	600	300		360			328	450	218	178	185	450	207	179
SV-80x80Zn classic-NYLON	650	240		270			254		181	163	161		176	166
SV-80x80 classic	650	325		430			400		255	195	233		238	193
SV-80x80BP classic	700	250							198	175	179		192	175
SV-80x80BP-Zn classic	700	350							297	214	275		274	209
SV-80x80 heavy	750	270							227	189	215		216	187
SV-80x80Zn heavy	750	375							347	235	322		315	225
SV-90x95-AL	800	400							404	257	370		361	243
SV-90x99-AL	800	600								418				362
SV-94x85 classic	900	675								555				459
SV-94x85Zn classic	1000	750												582
SV-94x85 heavy	1100	825												617
SV-94x85Zn heavy	1200	900												774
SV-136x142 classic	1300	1000												850
SV-136x142Zn classic														716
SV-136x142 heavy														
SV-136x142Zn heavy														

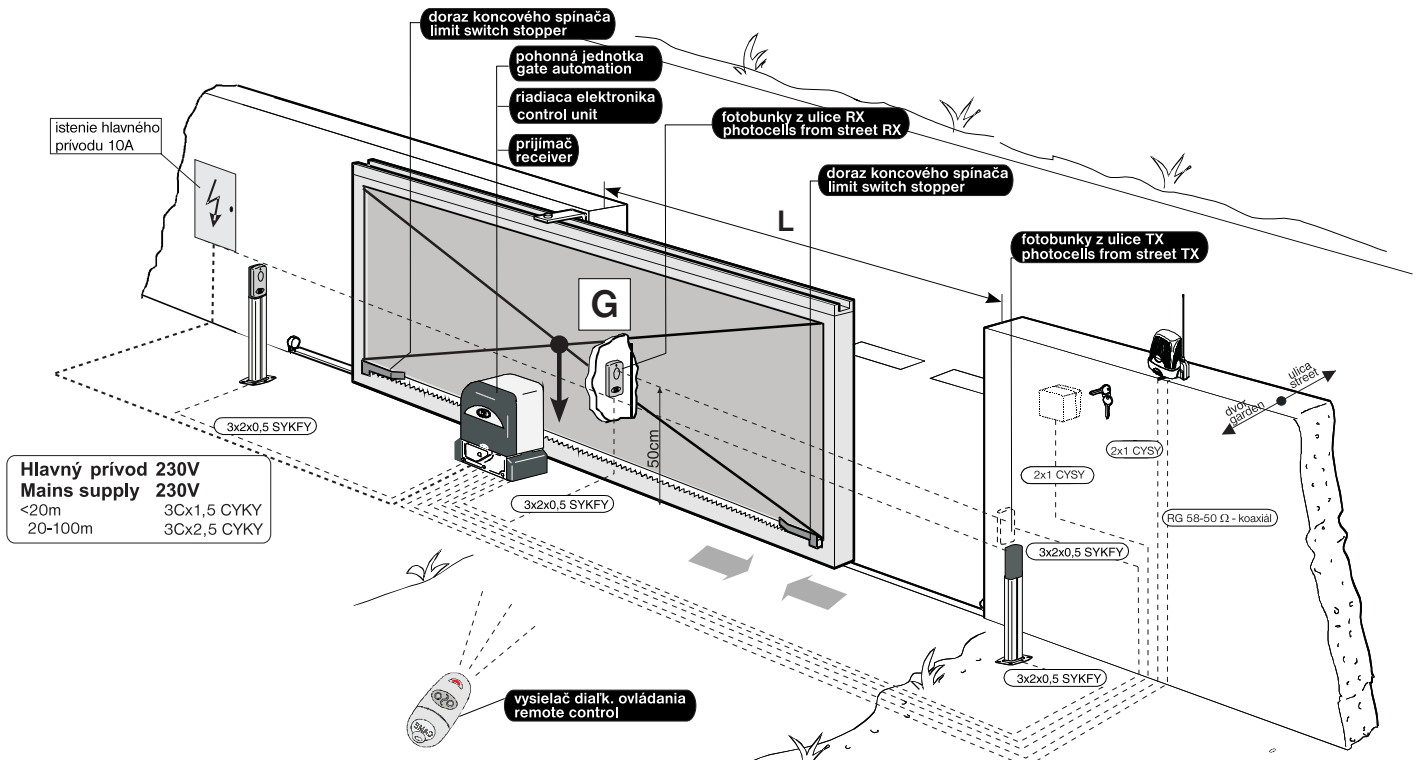



Orientačné rozmery pre privátne použitie (G(kg)=G_G+G_P (G_G = hmotnosť brány bez samonosného profilu)/Approximate dimensions for private using



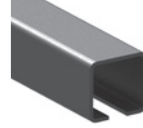
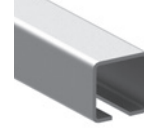





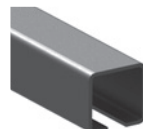
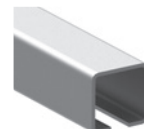



Goptimal (Gmax.)					
	200 (400) kg	300 (600) kg	400 (800) kg	600 (1200) kg	>600 (1800) kg
	300 (400) kg	400 (600) kg	550 (800) kg	800 (1200) kg	>800 (1800) kg
 <i>tot</i>	 DRIFT-40-SMART	 DRIFT-80-SMART			
	 ROAD-400 ROBUS400-BDKIT	 ROBO-600	<i>tot</i> ROBUS600-BDKIT	 ROX-1000	 RUN1800-ZKIT THOR-1500
	 BX-PLUS-AGS-ZKIT BXV-4-ZKIT	<i>tot</i> BX-STRONG-AGS-ZKIT BXV-8-ZKIT		 BKS-1200	 BKS-1800 BKS-2200
	 TURBO50-ZKIT-R	 TURBO80-ZKIT-R			

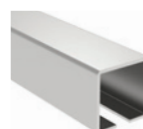



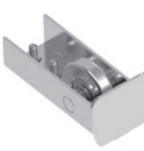

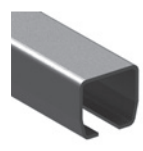
MODEL Fe/Zn 60x60 L4m/G_e150kg 						
	H/34BP-4-60x60-NYLON	H/14N-60x60	H/15P-60	H/258-60x60	H/02-60x60-Fe-6000	H/02-60x60-Zn-6000
SV-60x60 ECO-NYLON	2x	1x	1x	1x	-	-
SV-60x60 clasic-NYLON	2x	1x	1x	1x	1x	-
SV-60x60Zn clasic-NYLON	2x	1x	1x	1x	-	1x



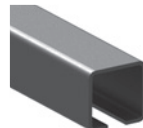
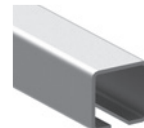

MODEL Fe/Zn 60x60 L4m/G_e200kg 						
	H/34BP-4-60x60	H/14N-60x60	H/15P-60	H/258-60x60	H/02-60x60-Fe-6000	H/02-60x60-Zn-6000
SV-60x60-ECO	2x	1x	1x	1x	-	-
SV-60x60 clasic	2x	1x	1x	1x	1x	-
SV-60x60Zn clasic	2x	1x	1x	1x	-	1x

MODEL INOX 60x60 L4m/G_e250kg 					
	H8/34-4-60x60	H8/14N-60x60	H8/15P-60	H8/40-60x60	H8/02-60x60-6000
SV-60x60-ECO-INOX	2x	1x	1x	1x	-
SV-60x60inox-clasic	2x	1x	1x	1x	1x

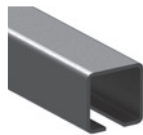
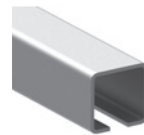



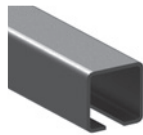
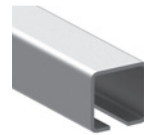

MODEL Fe/Zn 70x60 L4m/G_e200kg 						
	H/34B-4-70x60	H/14N-70x60	H/15P-70	H/40-70x60P	H/02-70x60-Fe-6000	H/02-70x60-Zn-6000
SV-70x60-ECO	2x	1x	1x	1x	-	-
SV-70x60 clasic	2x	1x	1x	1x	1x	-
SV-70x60Zn clasic	2x	1x	1x	1x	-	1x



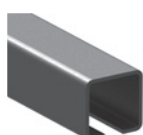
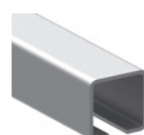

MODEL Fe/Zn 70x70 L4m/G_e175kg 						
	H/34-4-70x70-NYLON	H/14N-70x70	H/15P-70	H/258-70x70	H/02-70x70-Fe-6000	H/02-70x70-Zn-6000
SV-70x70-ECO-NYLON	2x	1x	1x	1x	-	-
SV-70x70 clasic-NYLON	2x	1x	1x	1x	1x	-
SV-70x70Zn clasic-NYLON	2x	1x	1x	1x	-	1x

MODEL Fe/Zn 70x70 L4m/Gc250kg 							
	H/34BP-4-70x70	H/14N-70x70	H/15P-70	H/258-70x70	H/02-70x70-Fe-6000	H/02-70x70-Zn-6000	M16X30
SV-70x70BP-ECO	2x	1x	1x	1x	-	-	8x
SV-70x70BP clasic	2x	1x	1x	1x	1x	-	8x
SV-70x70BP-Zn clasic	2x	1x	1x	1x	-	1x	8x





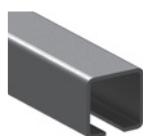
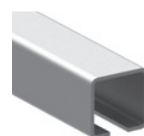

MODEL Fe/Zn 70x70 L4m/Gc250kg 						
	H/34-4-70x70P	H/14N-70x70	H/15P-70	H/258-70x70	H/02-70x70-Fe-6000	H/02-70x70-Zn-6000
SV-70x70-ECO	2x	1x	1x	1x	-	-
SV-70x70 clasic	2x	1x	1x	1x	1x	-
SV-70x70Zn clasic	2x	1x	1x	1x	-	1x





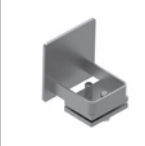

MODEL Fe/Zn 80x80 L4m/Gc200kg 						
	H/34-4-80x80-NYLON	H/14N-80x80	H/15P-80	H/258-80x80	H/02-80x80-Fe-6000	H/02-80x80-Zn-6000
SV-80x80-ECO-NYLON	2x	1x	1x	1x	-	-
SV-80x80 clasic-NYLON	2x	1x	1x	1x	1x	-
SV-80x80Zn clasic-NYLON	2x	1x	1x	1x	-	1x





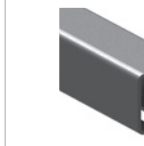

MODEL Fe/Zn 80x80 L4,5m/Gc250kg 							
	H/34BP-4-80x80	H/14N-80x80	H/15P-80	H/258-80x80	H/02-80x80-Fe-6000	H/02-80x80-Zn-6000	M16x30
SV-80x80BP-ECO	2x	1x	1x	1x	-	-	8x
SV-80x80BP clasic	2x	1x	1x	1x	1x	-	8x
SV-80x80BP-Zn clasic	2x	1x	1x	1x	-	1x	8x

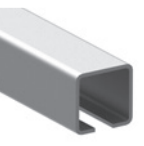
MODEL Fe/Zn 80x80 L4,5m/Gc250kg 						
	H/34-4-80x80P	H/14N-80x80	H/15P-80	H/258-80x80	H/02-80x80-Fe-6000	H/02-80x80-Zn-6000
SV-80x80-ECO	2x	1x	1x	1x	-	-
SV-80x80 clasic	2x	1x	1x	1x	1x	-
SV-80x80Zn clasic	2x	1x	1x	1x	-	1x





top

MODEL INOX 80x80 L4,5m/Gc300kg 					
	H8/34-4-80x80	H8/14N-80x80	H8/15P-80	H8/40-80x80	H8/02-80x80-6000
SV-80x80-ECO-INOX	2x	1x	1x	1x	-
SV-80x80inox-clasic	2x	1x	1x	1x	1x

MODEL Fe/Zn 80x80 L7m/Gc300kg 							
	H/34-8-80x80-HEAVY	H/14N-80x80	H/15P-80	H/258-80x80	H/02-80x80-Fe-3000	H/02-80x80-Fe-6000	H/02-80x80-Zn-3000
SV-80x80-ECO-HEAVY	2x	1x	1x	1x	-	-	-
SV-80x80 heavy	2x	1x	1x	1x	1x	1x	-
SV-80x80Zn heavy	2x	1x	1x	1x	-	-	1x



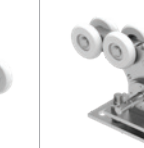
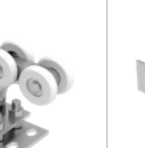
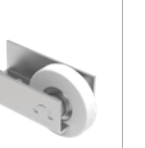



MODEL Al 90x95 L4m/Gc200kg 						
	H/34-4-90x95-NYLON	H/14N-90x95-NYLON	H/15P-100	H/40-90x95P	H/02-90x95-AL-6000	
SV-90x95-AL-ECO	2x	1x	1x	2x	-	
SV-90x95-AL	2x	1x	1x	2x	1x	



new



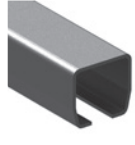

MODEL Al 90x99 L4m/Gc200kg 						
	H/34B-4-90x99-NYLON	H/34B-4G-90x99-NYLON	H8/14N-90x95	H8/15P-100	H8/40-90x99P	H/02-90x99-AL-6000
SV-90x99-AL-ECO	1x	1x	1x	1x	2x	-
SV-90x99-AL	1x	1x	1x	1x	2x	1x

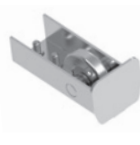
new

MODEL Fe/Zn 94x85 L6m/Ge300kg 								
	H/34B-4-94x85	H/14N-94x85	H/15P-100	H/40-94x85P	H/02-94x85-Fe-3000	H/02-94x85-Fe-6000	H/02-94x85-Zn-3000	H/02-94x85-Zn-6000
SV-94x85-ECO	2x	1x	1x	1x	-	-	-	-
SV-94x85 classic	2x	1x	1x	1x	1x	1x	-	-
SV-94x85Zn classic	2x	1x	1x	1x	-	-	1x	1x

MODEL Fe/Zn 94x85 L8m/Ge500kg 								
	H/34B-8-94x85-HEAVY	H/14N-94x85	H/15P-100	H/40-94x85P	H/02-94x85-Fe-6000		H/02-94x85-Zn-6000	
SV-94x85-ECO-HEAVY	2x	1x	1x	1x	-		-	
SV-94x85 heavy	2x	1x	1x	1x	2x		-	
SV-94x85Zn heavy	2x	1x	1x	1x	-		2x	

MODEL Fe/Zn 136x142 L9m/Ge600kg 								
	H/34B-4-136x142	H/14N-136x142	H/15P-145	H/40-136x142P	H/02-136x142-Fe-6000		H/02-136x142-Zn-6000	
SV-136x142-ECO	2x	1x	1x	1x	-		-	
SV-136x142 classic	2x	1x	1x	1x	2x		-	
SV-136x142Zn classic	2x	1x	1x	1x	-		2x	

MODEL Fe/Zn 136x142 L11m/Ge800kg 								
	H/34B-8-136x142-HEAVY	H/14N-136x142	H/15P-145	H/40-136x142P	H/02-136x142-Fe-3000	H/02-136x142-Fe-6000	H/02-136x142-Zn-3000	H/02-136x142-Zn-6000
SV-136x142-ECO-HEAVY	2x	1x	1x	1x	-	-	-	-
SV-136x142 heavy	2x	1x	1x	1x	1x	2x	-	-
SV-136x142Zn heavy	2x	1x	1x	1x	-	-	1x	2x

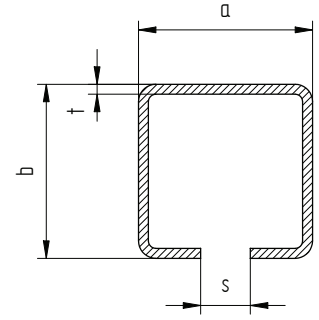
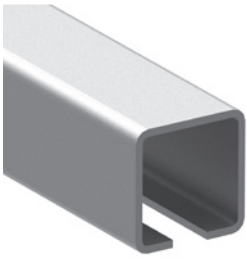

Quality	Finish	art.	a	b	t	s	L
Fe	raw	H/02-60x60-Fe-3000	60	60	4	15	3000
		H/02-60x60-Fe-6000					6000
	Zn	H/02-60x60-Zn-3000	60	60	4	15	3000
		H/02-60x60-Zn-6000					6000
		H/02-60x60-Zn-7000					7000
	raw	H/02-70x70-Fe-3000	70	70	4	20	3000
		H/02-70x70-Fe-6000					6000
		H/02-70x70-Fe-7000					7000
	Zn	H/02-70x70-Zn-3000	70	70	4	20	3000
		H/02-70x70-Zn-6000					6000
		H/02-70x70-Zn-7000					7000
	raw	H/02-80x80-Fe-3000	80	80	5	25	3000
H/02-80x80-Fe-6000		6000					
H/02-80x80-Fe-3000		3000					
Zn	H/02-80x80-Zn-3000	78	78	4	20	6000	
	H/02-80x80-Zn-6000					6000	
	H/02-80x80-Zn-7000					7000	
AISI304	raw	H8/02-60x60-3000	58	58	3	15	3000
		H8/02-60x60-6000					6000
	raw	H8/02-80x80-3000	76	76	20	20	3000
		H8/02-80x80-6000					6000

new

new

top

top

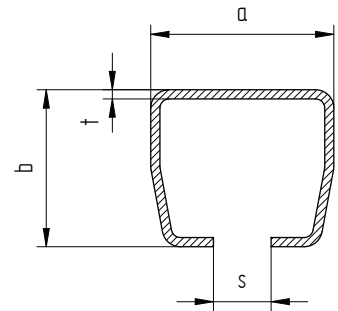
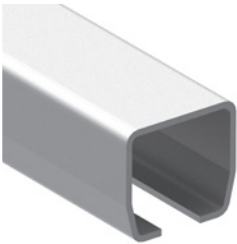

Quality	Finish	art.	a	b	t	s	L
Fe	raw	H/02-70x60-Fe-3000	70	60	3,5	22	3000
		H/02-70x60-Fe-6000					6000
	Zn	H/02-70x60-Zn-3000	70	60	3,5	22	3000
		H/02-70x60-Zn-6000					6000
	raw	H/02-94x85-Fe-3000	94	85	5	33	3000
		H/02-94x85-Fe-6000					6000
		H/02-94x85-Fe-3000					3000
	Zn	H/02-94x85-Zn-3000	94	85	5	33	3000
		H/02-94x85-Zn-6000					6000
		H/02-94x85-Zn-6000					6000
	raw	H/02-136x142-Fe-3000	136	142	6	38	3000
		H/02-136x142-Fe-6000					6000
H/02-136x142-Fe-3000		3000					
Zn	H/02-136x142-Zn-3000	136	142	6	38	3000	
	H/02-136x142-Zn-6000					6000	

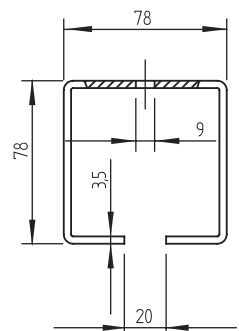
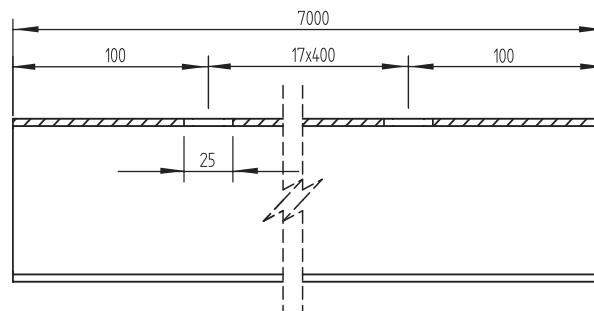

Quality	Finish	art.
Fe	Zn	H/02-80x80-Zn-D-7000

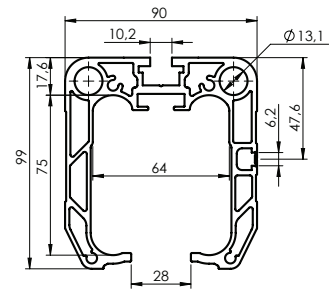
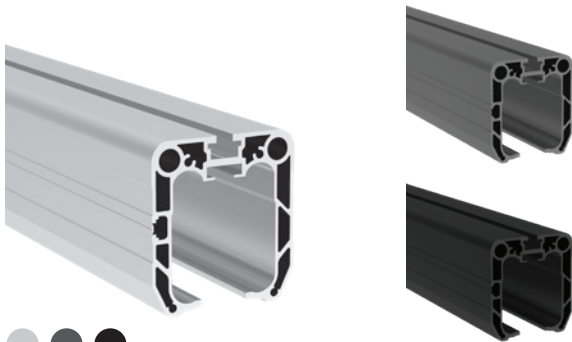

Quality	Finish	art.	Color	L		
ALUMINIUM	natural	H/02-90x99-AL-6000	-			<i>new</i>
		H/02-90x99-AL-BLACK-6000	black	6000		<i>new</i>
		H/02-90x99-AL-ANTHR-6000	anthracite			<i>new</i>
		H/02-90x99-AL-7000	-			<i>new</i>
		H/02-90x99-AL-BLACK-7000	black	7000		<i>new</i>
		H/02-90x99-AL-ANTHR-7000	anthracite			<i>new</i>

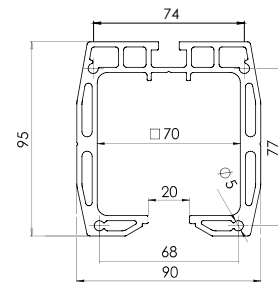
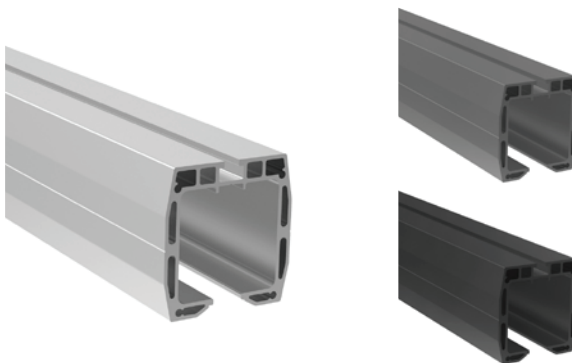
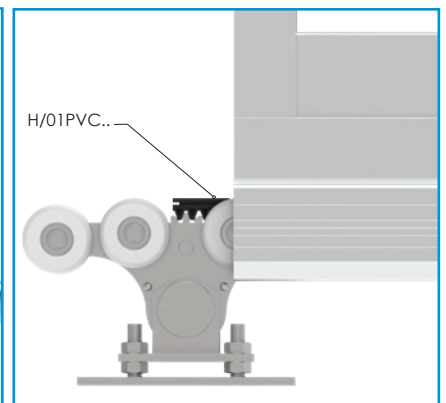
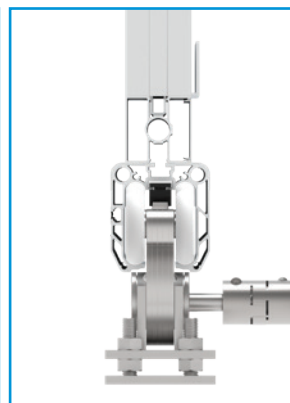
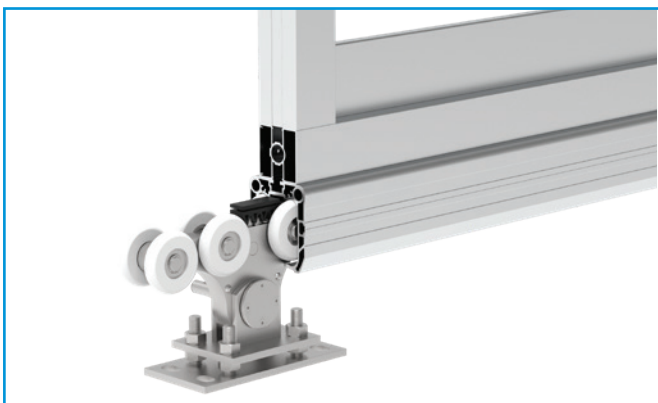

Quality	Finish	art.	Color	L		
ALUMINIUM	natural	H/02-90x95-AL-6000	-			<i>new</i>
		H/02-90x95-AL-BLACK-6000	black	6000		<i>new</i>
		H/02-90x95-AL-ANTHR-6000	anthracite			<i>new</i>

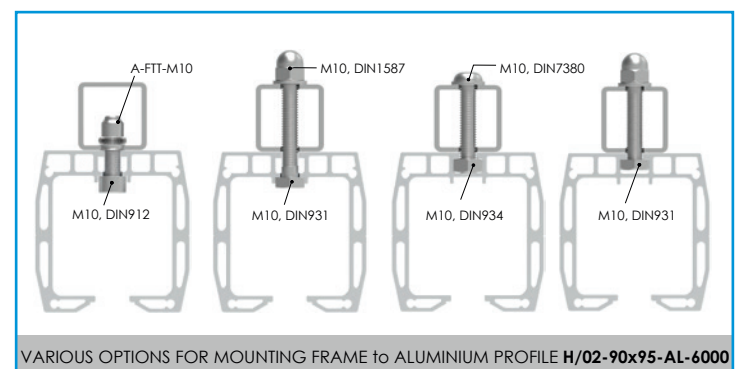
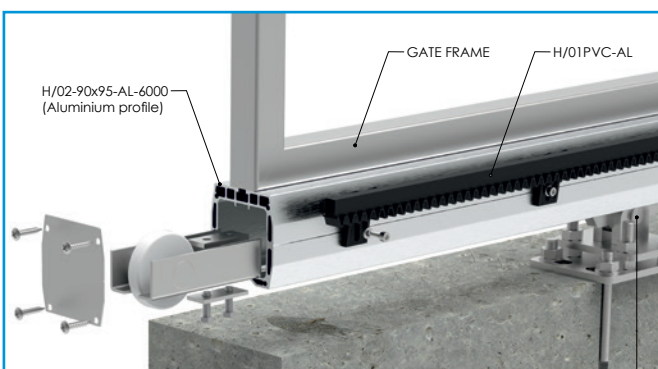

VARIOUS OPTIONS FOR MOUNTING FRAME to ALUMINIUM PROFILE H/02-90x95-AL-6000

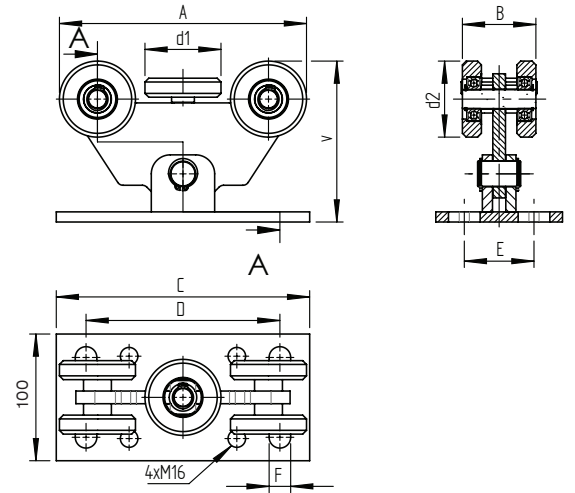
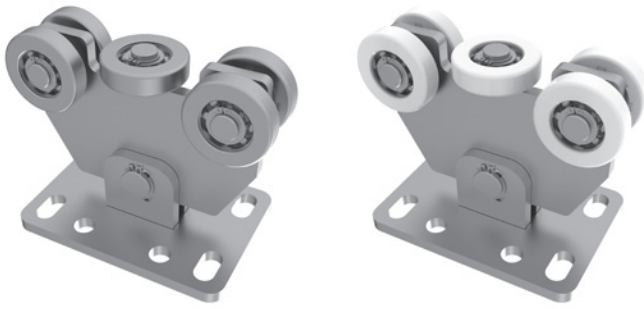

Quality	Finish	art.	v	d1	d2	A	B	C	D	E	F
Fe	Zn	H/34BP-4-60x60	128	50	50	165	44	145	115	60	13
		H/34BP-4-60x60-NYLON									
AISI304	raw	H8/34BP-4-60x60									
Fe	Zn	H/34BP-4-70x70	130	60	60	195	58	200	152	55	17
		H/34BP-4-80x80	132	68	68	203	61	200	152	56	18

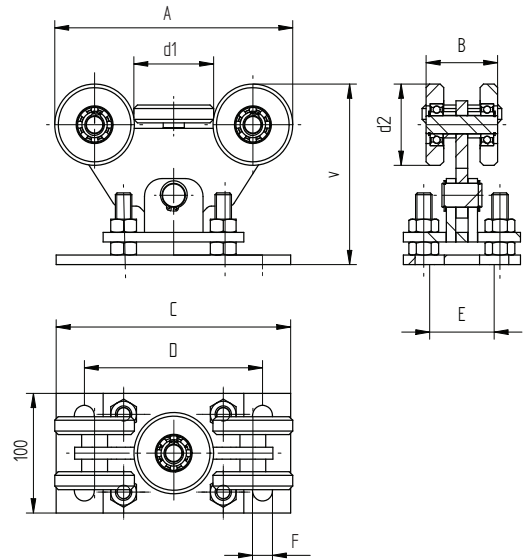

Quality	Finish	art.	v	v max	d1	d2	A	B	C	D	E	F
Fe	Zn	H/34-4-60x60P	146	166	51	50	165	44	115	145	60	13
AISI304	raw	H8/34-4-60x60										
		H/34-4-70x70P			60	60	195	58				
Fe	Zn	H/34-4-70x70-NYLON	150	170	68	68	203	61	200	152	55	17
		H/34-4-80x80P										
		H/34-4-80x80-NYLON										
AISI304	raw	H8/34-4-80x80										
Fe	Zn	H/34-4-90x95-NYLON			69,5	69,5	206	62				

new
new

new

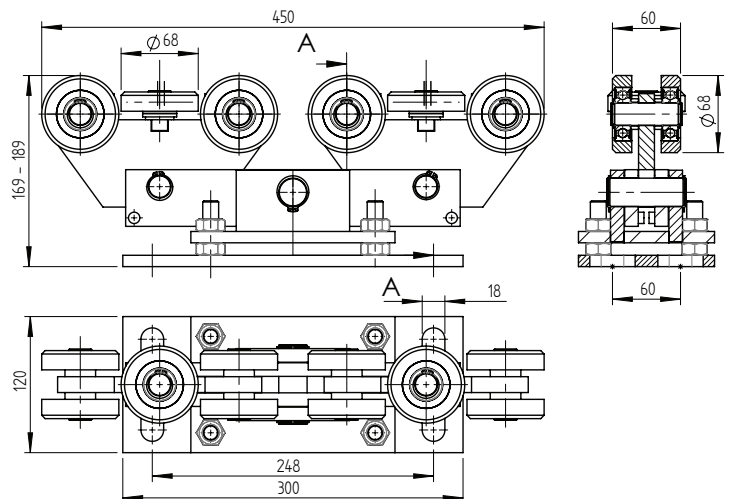
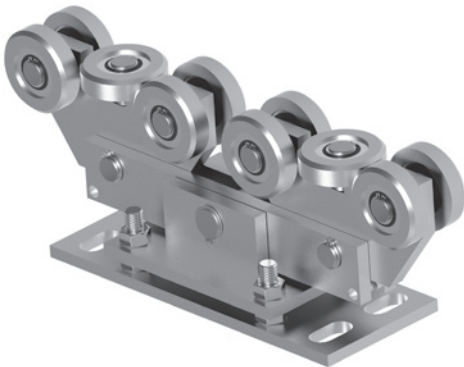

Quality	Finish	art.
Fe	Zn	H/34-8-80x80-HEAVY

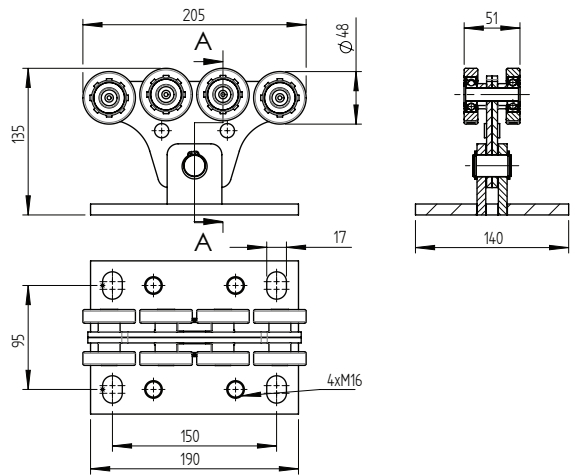

Quality	Finish	art.
Fe	Zn	H/34B-4-70x60

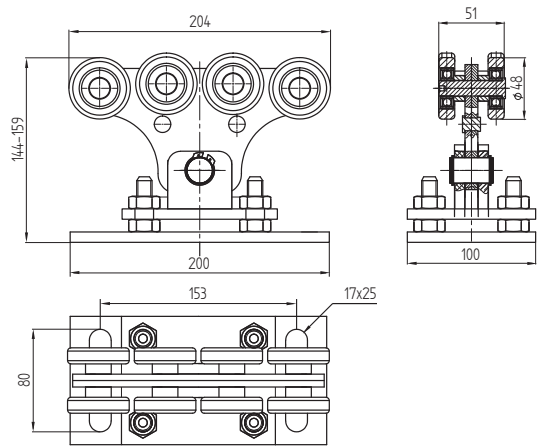

Quality	Finish	art.
Fe	Zn	H/34-4-70x60

new

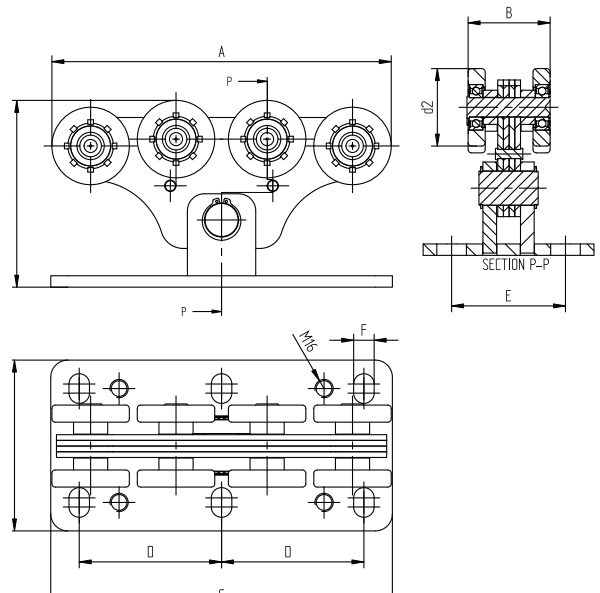

Quality	Finish	art.	v	d2	A	B	C	D	E	F	G
Fe	Zn	H/34B-4-94x85	164	68	298	72	300	125	104	18	150
		H/34B-4-136x142	263	113	470	103	470	210	150	17	200

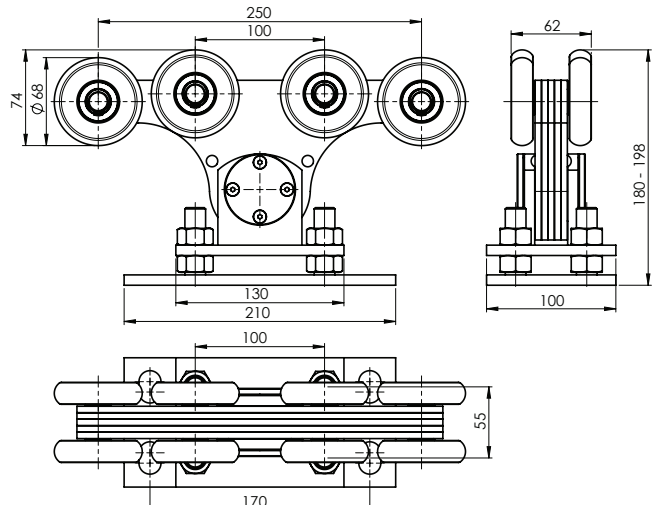
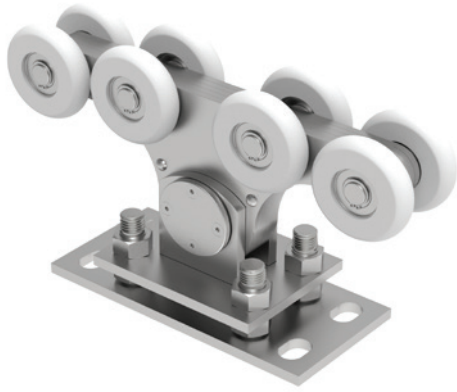

Quality	Finish	art.
Fe	Zn	H/34B-4-90x99-NYLON <i>new</i>

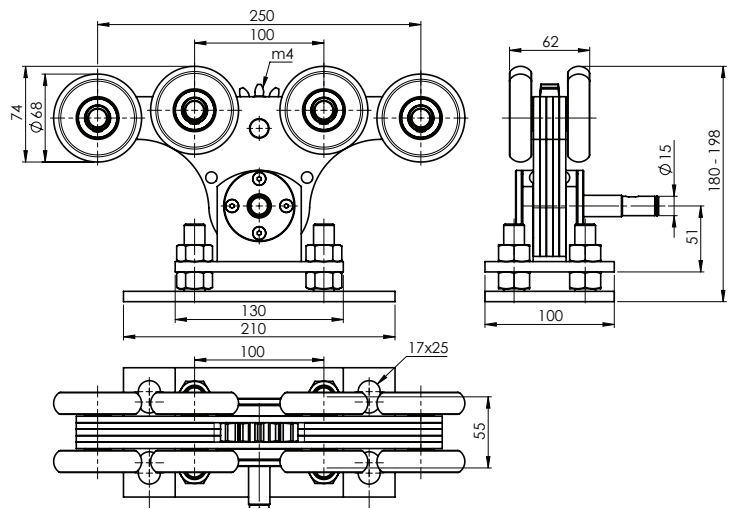
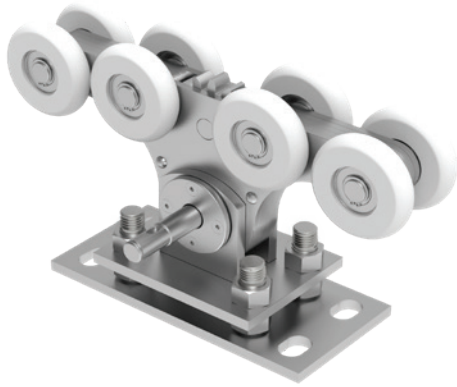

Quality	Finish	art.
Fe	Zn	H/34B-4G-90x99-NYLON <i>new</i>

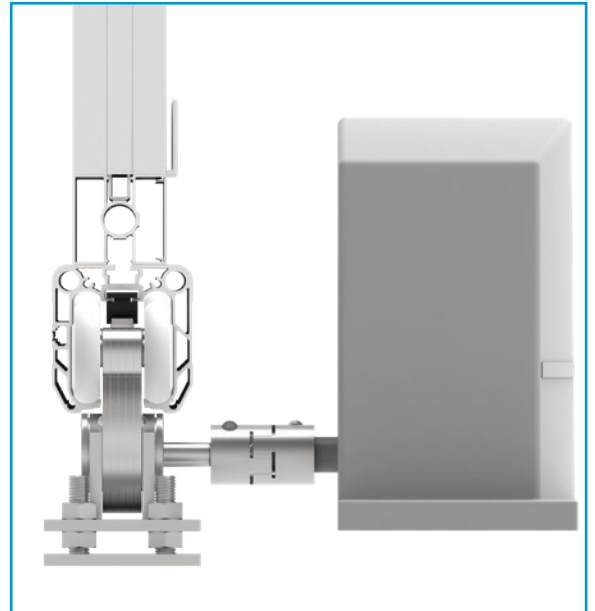
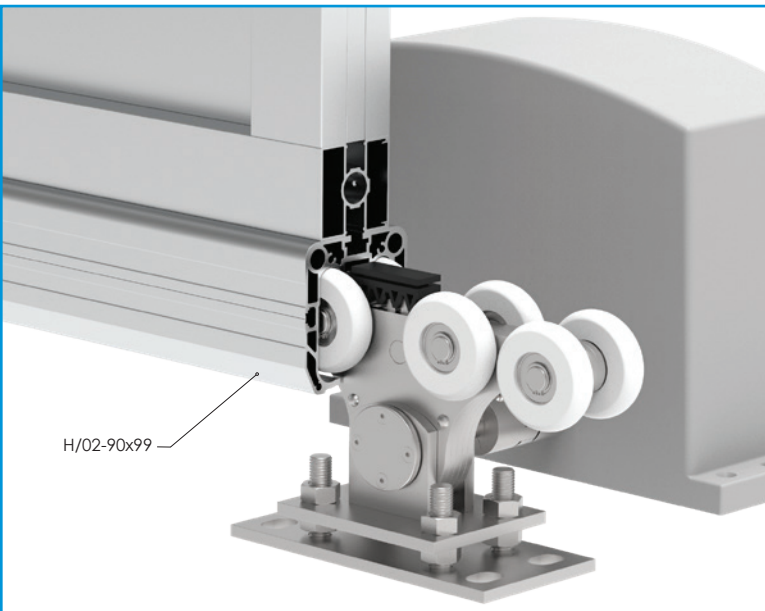

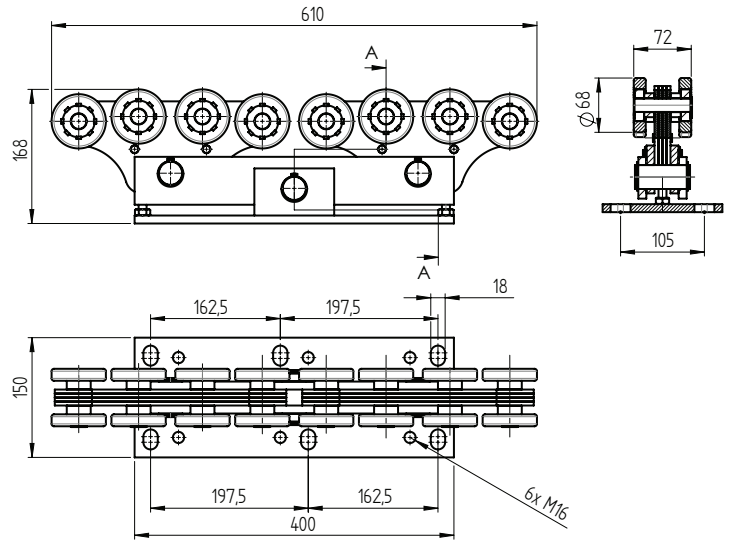
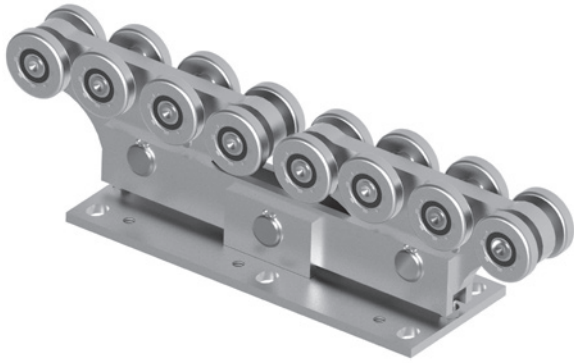

Quality	Finish	art.
Fe	Zn	H/34B-8-94x85-HEAVY

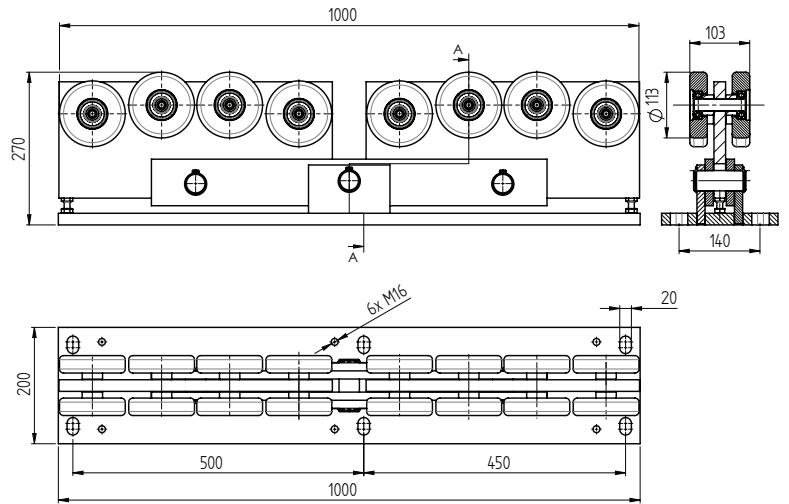

Quality	Finish	art.
Fe	Zn	H/34B-8-136x142-HEAVY

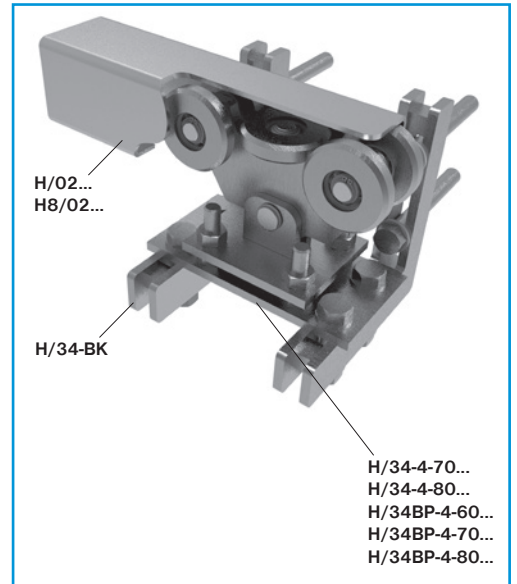
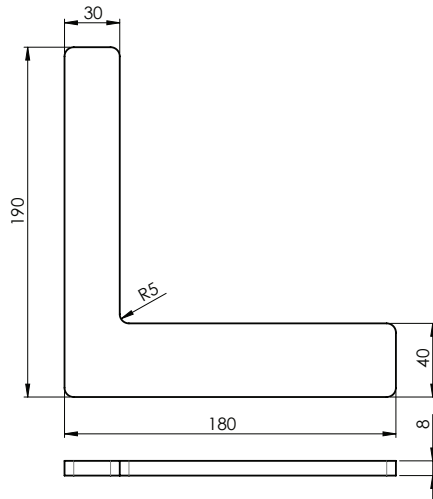

Quality	Finish	art.
Fe	raw	H/34-BK

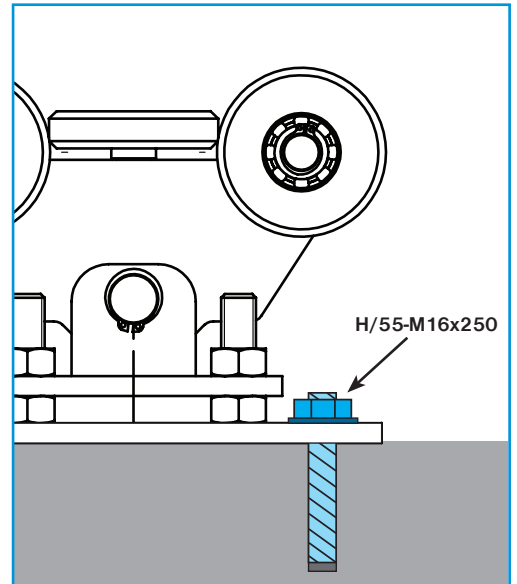
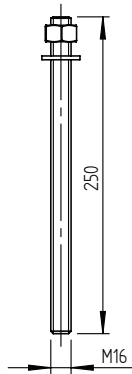
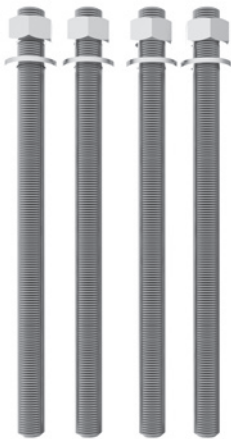

Quality	Finish	art.
Fe	Zn	H/55-M16x250

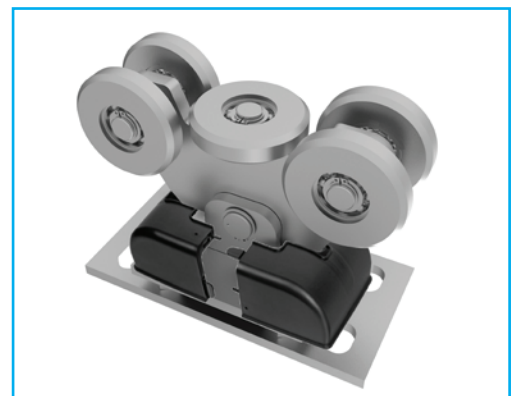

Quality	Finish	art.
PVC	raw	H/34-COVER

new

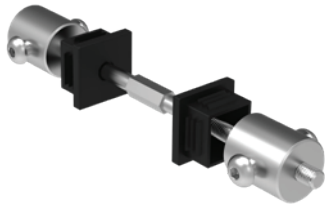
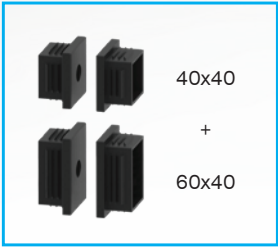
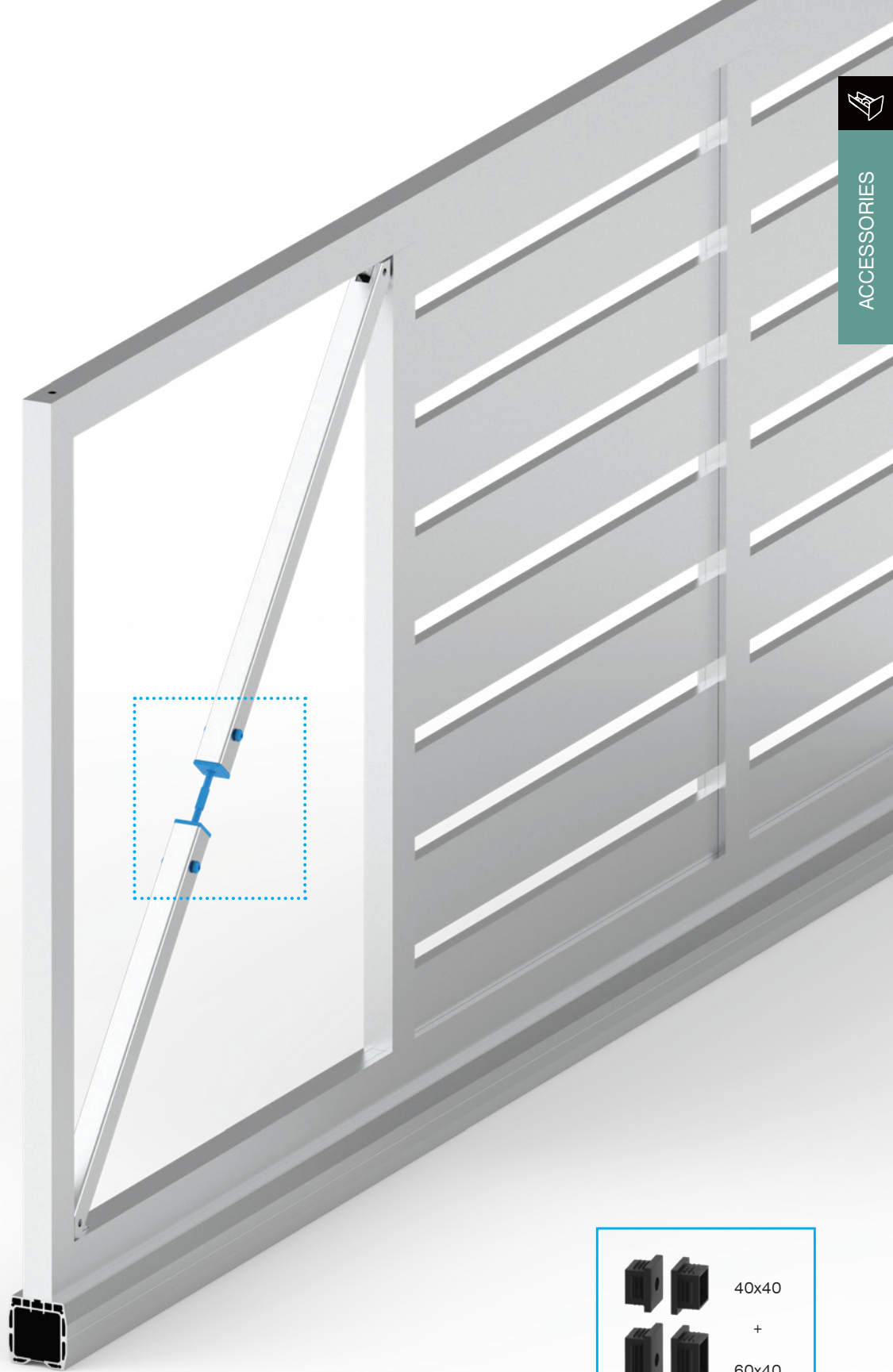

Quality	Finish	art.
Fe	Zn	H/65-40x40

new

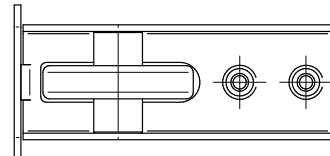
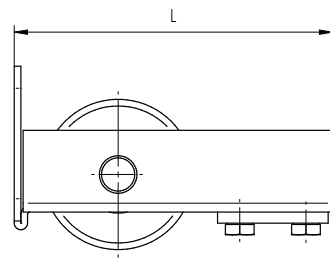
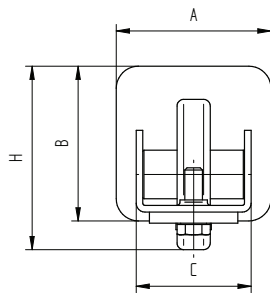
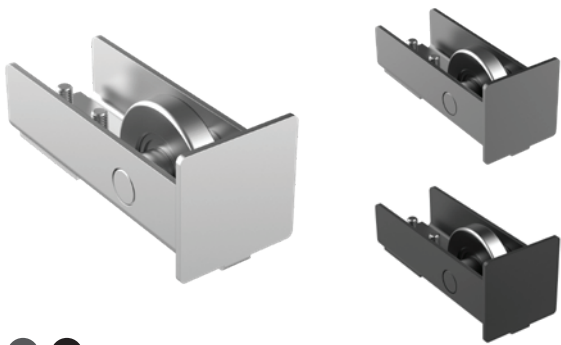

Quality	Finish	art.	Color	A	B	C	H	L
Fe	Zn	H/14N-60x60	-	60	60	51	72	143
		H/14N-60x60-BLACK	black					
		H/14N-60x60-ANTHR	anthracite					
AISI304	raw	H8/14N-60x60	-					
Fe	Zn	H/14N-70x70	-	70	70	52	83	144
		H/14N-70x70-BLACK	black					
		H/14N-70x70-ANTHR	anthracite					
		H/14N-80x80	-					
Fe	Zn	H/14N-80x80-BLACK	black	80	80	61	92	149
		H/14N-80x80-ANTHR	anthracite					
AISI304	raw	H8/14N-80x80	-	76	76			

new
new
new
new
new

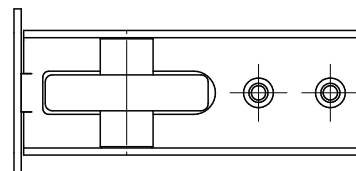
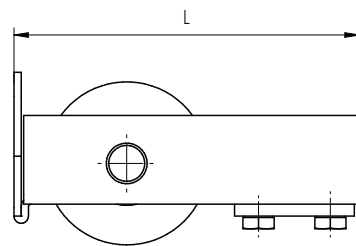
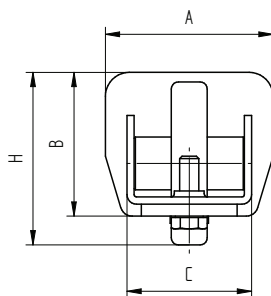
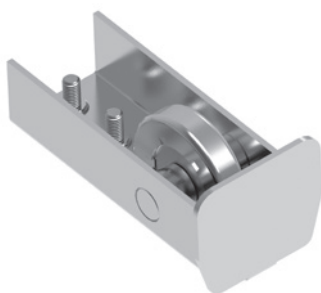

Quality	Finish	art.	A	B	C	H	L
Fe	Zn	H/14N-70x60	70	60	52	72	144
		H/14N-94x85	94	85	66	96	143
		H/14N-136x142	138	142	103	161	198

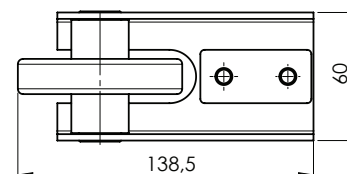
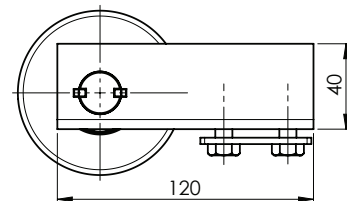
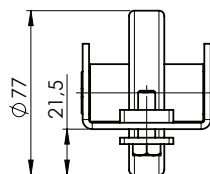

Quality	Finish	art.
Fe	Zn	H/14N-90x95-NYLON
AISI304	raw	H8/14N-90x99-NYLON

new
new

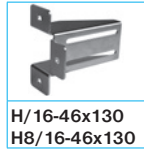
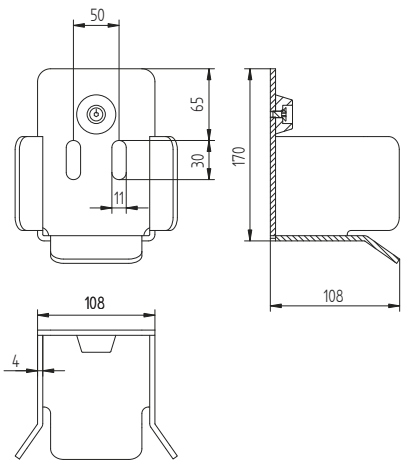
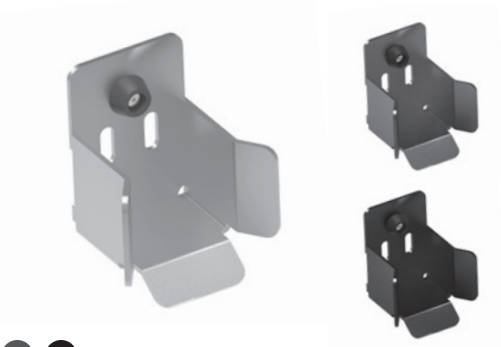

Quality	Finish	art.	Color	A	B	h	s	H
Fe	Zn	H/15P-60	-					
		H/15P-60-BLACK	black		74	56	31	102
		H/15P-60-ANTHR	anthracite					
AISI304	raw	H8/15P-60	-	130				
		H/15P-70	-					
Fe	Zn	H/15P-70-BLACK	black		90	55	35	100
		H/15P-70-ANTHR	anthracite					
		H/15P-80	-					
		H/15P-80-BLACK	black		135	98	55	95
		H/15P-80-ANTHR	anthracite					
AISI304	raw	H8/15P-80	-					
		H/15P-100	-					
Fe	Zn	H/15P-100-BLACK	black		170	108	65	108
		H/15P-100-ANTHR	anthracite					
AISI304	raw	H8/15P-100	-					
Fe	Zn	H/15P-145	-		225	150	75	105

new
new
new
new
new
new
new
new
new
new

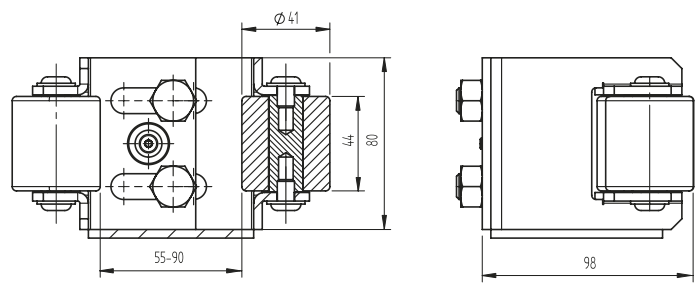
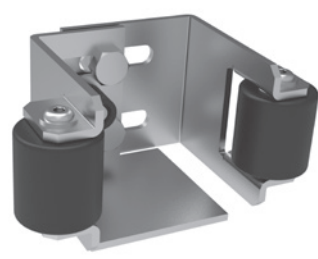

Quality	Finish	art.
Fe	Zn	H/15P-55-90

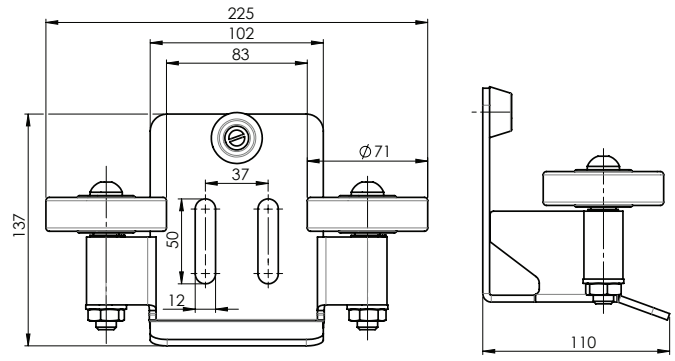
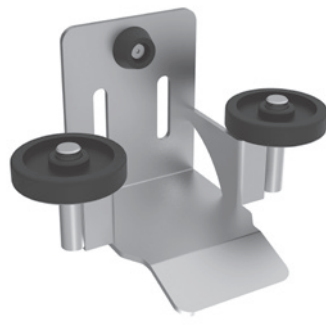

Quality	Finish	art.
Fe	Zn	H/15P-80-NYLON

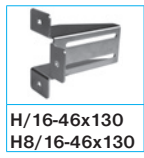

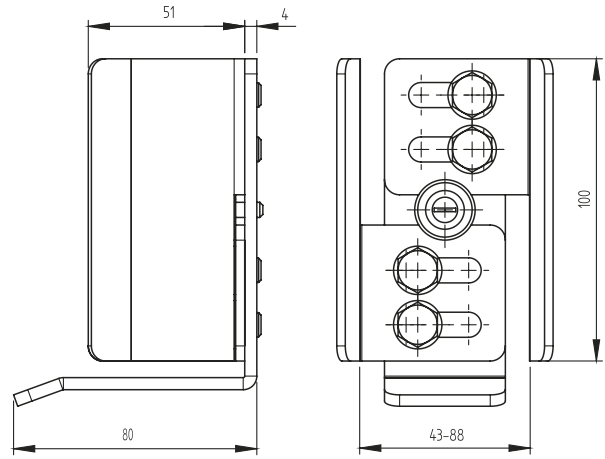
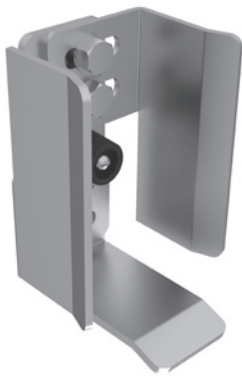

Quality	Finish	art.
Fe	Zn	H/11

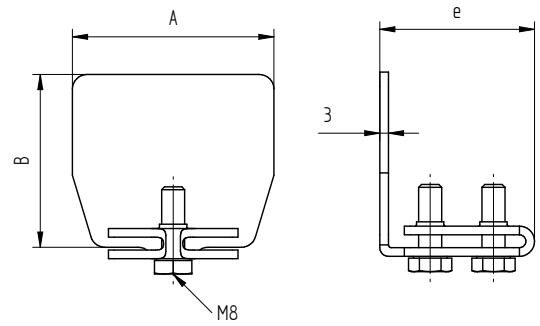
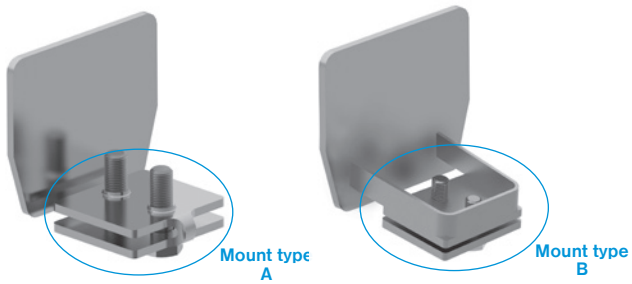

Quality	Finish	art.	A	B	e	Mount type
Fe	Zn	H/40-70x60P	70	60	53	A
		H/40-94x85P	94	85		
		H/40-136x142P	136	142	92	B

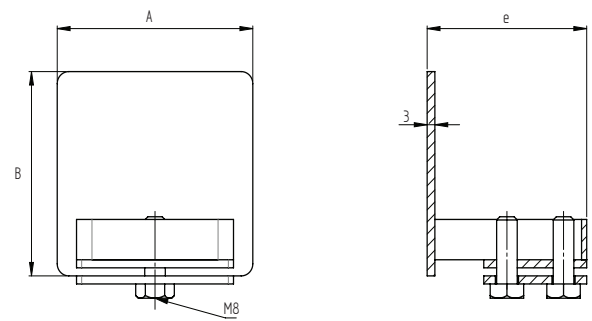
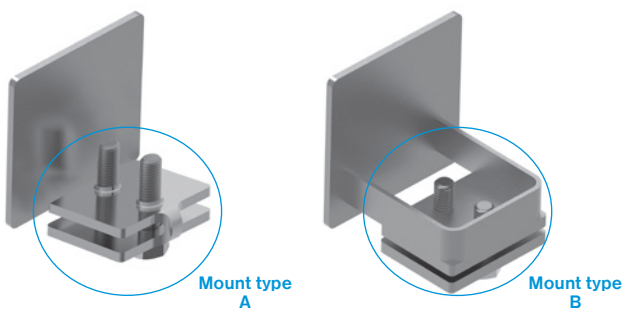

Quality	Finish	art.	A	B	e	Mount type
AISI304	raw	H8/40-60x60	60	60	53	A
Fe	Zn	H/40-70x70P	70	70		
		H/40-80x80P	80	80		
AISI304	raw	H8/40-80x80	76	76	62	B

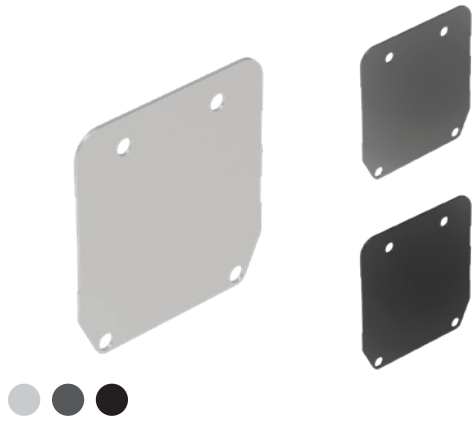

Quality	Finish	art.	Color
AISI304	raw	H8/40-90x99P	-
		H8/40-90x99P-BLACK	black
		H8/40-90x99P-ANTHR	anthracite

new
new
new

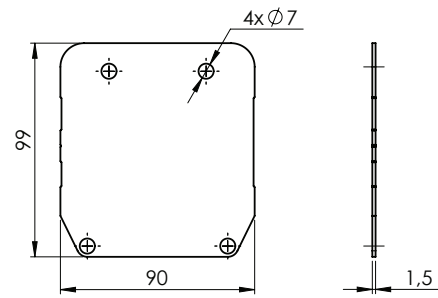

H/02-90x99-AL...



Quality	Finish	art.	Color
Fe	Zn	H/40-90x95P	-
		H/40-90x95P-BLACK	black
		H/40-90x95P-ANTHR	anthracite

new
new
new

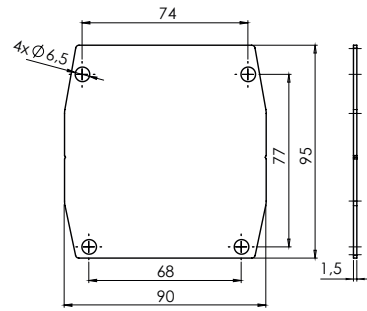

H/02-90x95-AL...

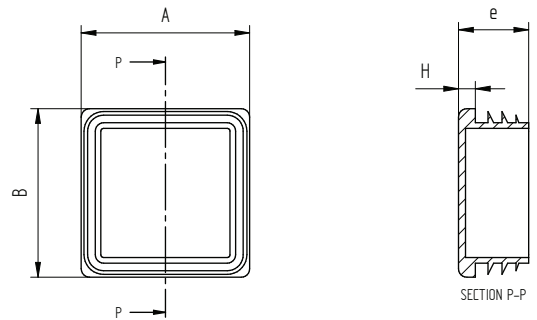

Quality	Finish	art.	A	B	H
PVC	Black	E2/258-40x40	40	40	4,8
		E2/258-50x50	50	50	2
		H/258-60x60	60	60	
		H/258-70x70	70	70	6
		H/258-80x80	80	80	

2 POSUVNÉ BRÁNY - KOLIESKOVÉ

ROLLING GATES



KOLIESKA
WHEELS



SPODNÉ VODIACE PROFILY
TRACKS



OBLÚKOVÁ KOLIESKOVÁ BRÁNA
CURVED ROLLING GATE

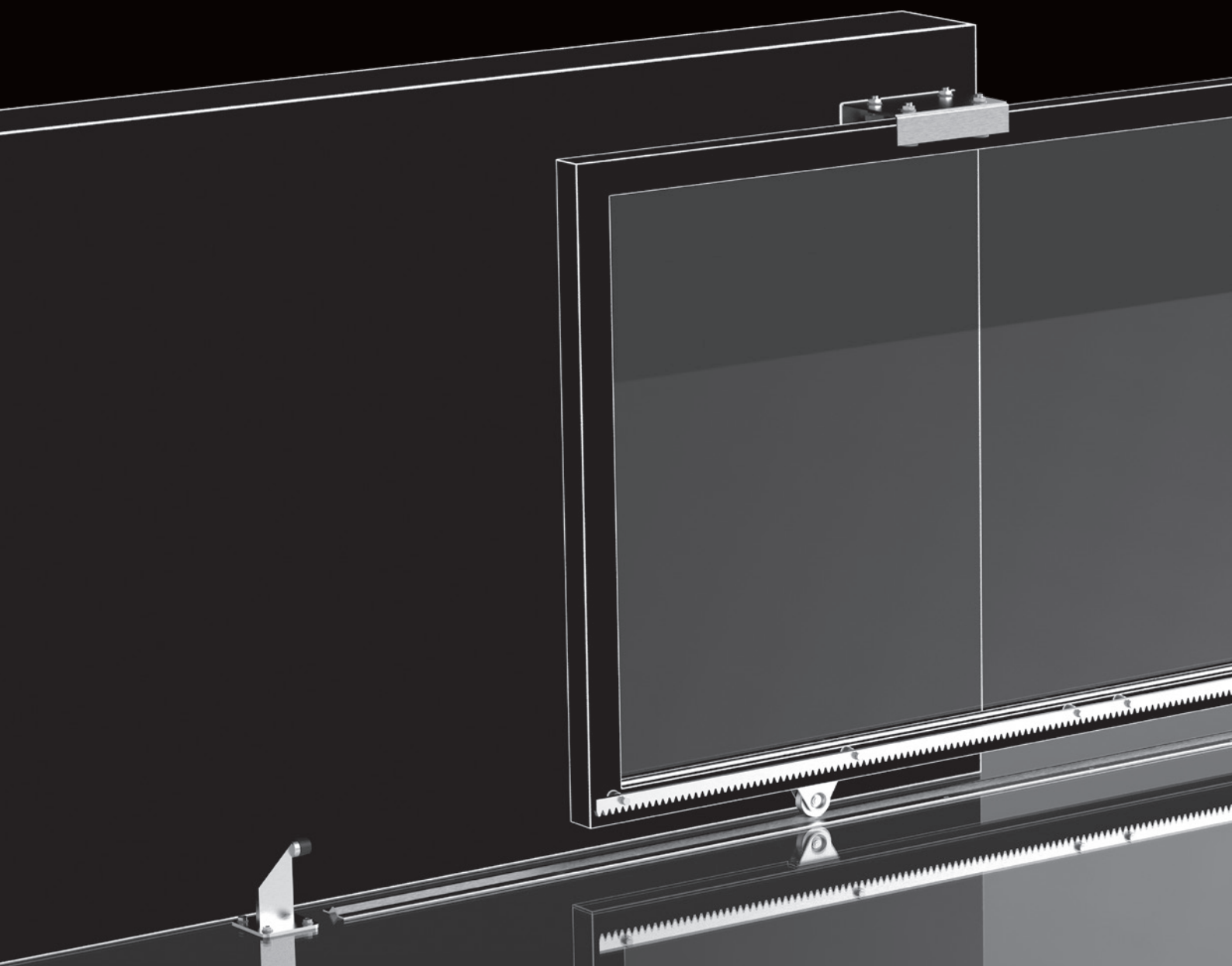

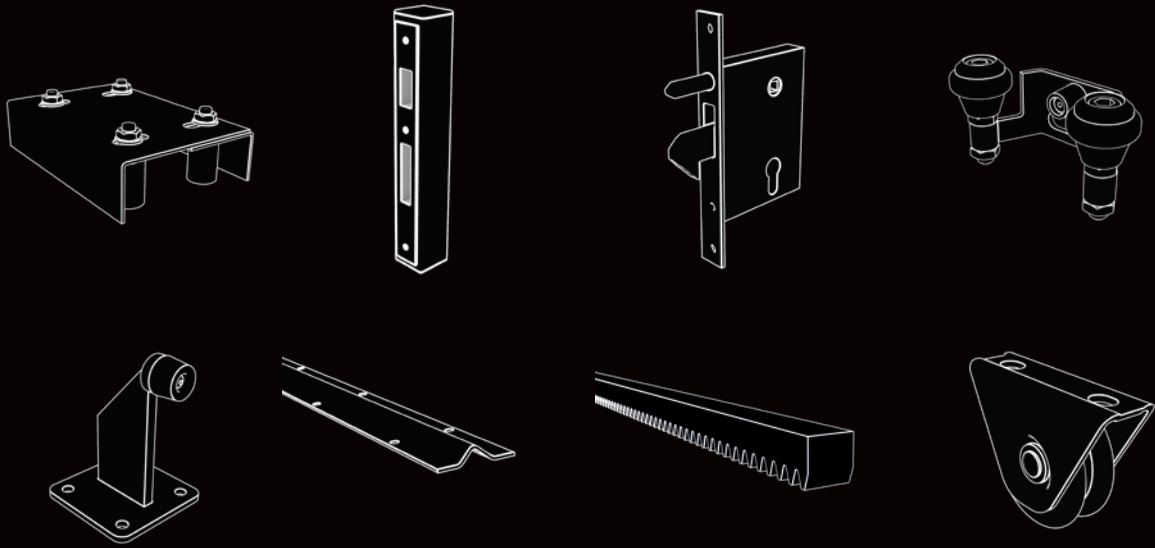

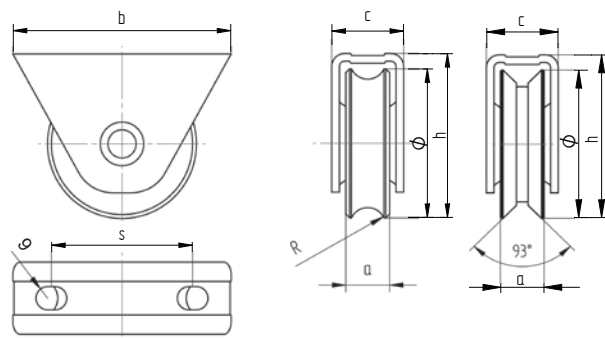

Quality	Finish	art.	Color	∅	H	h	R	a	b	c	s	Gmax/2pcs (kg)						
Fe	Zn	H/31U-60	-															
		H/31U-60-BLACK	black	58	75	64		17	85	27	55		200					
		H/31U-60-ANTHR	anthracite									8						
		H/31U-80C	-															
		H/31U-80C-BLACK	black									20		✓				
AISI304	raw	H/31U-80C-ANTHR	anthracite	78	95	85				100	35	70	300					
		H8/31U-80-R10	-									23						
		H8/31U-80-R10-NYLON	-									25						
Fe	Zn	H/31U-100	-	98	115	105	8	22	132		102	400						
		H/31V-60	-															
AISI304	raw	H8/31V-60-NYLON	-															
Fe	Zn	H/31V-60	-															
		H/31V-60-BLACK	black	58	75	64		17	85	27	55		200					
		H/31V-60-ANTHR	anthracite															
		H/31V-80C	-															
		H/31V-80C-BLACK	black															
AISI304	raw	H/31V-80C-ANTHR	anthracite	78	95	85				20	100	35	70	300				
		H8/31V-80	-															
		H8/31V-80-NYLON	-															
Fe	Zn	H/31V-100	-	98	115	106		22	132		102	350						

Top
new
new
new
new
new
Top
new
new
new
new
new
new
new
new

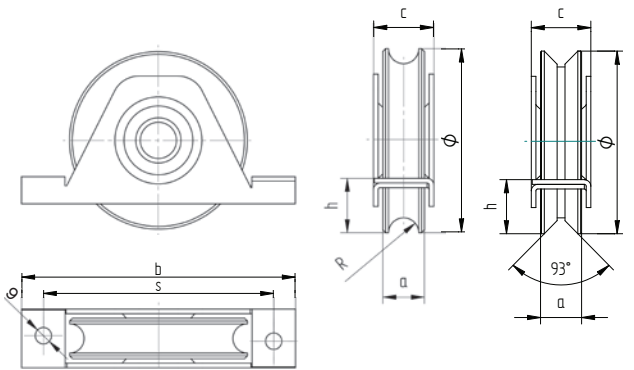
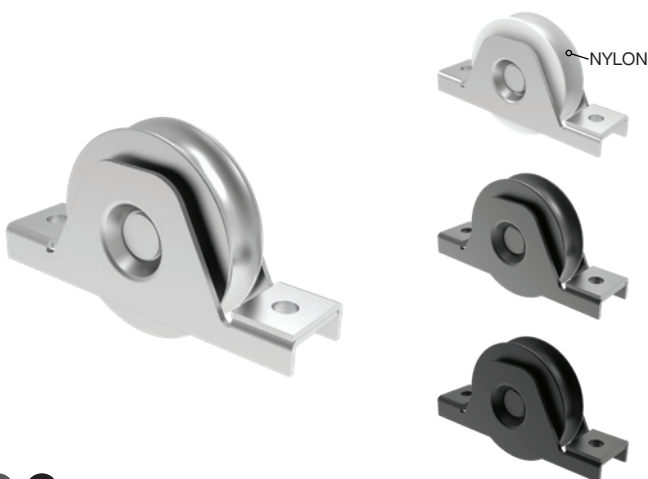
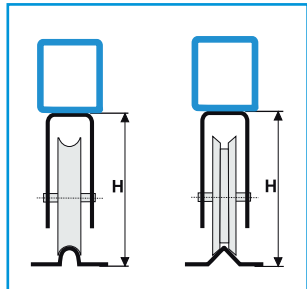

Quality	Finish	art.	Color	∅	H	h	R	a	b	c	s	Gmax/2pcs (kg)						
Fe	Zn	H/38U-80C	-															
		H/38U-80C-BLACK	black															
		H/38U-80C-ANTHR	anthracite	78	37	28					135	32	110	250	✓			
AISI304	raw	H8/38U-80-R10	-															
		H8/38U-80-R10-NYLON	-															
Fe	Zn	H/38U-100	-	98	40	32	8	22	150		127	300						
		H/38V-80C	-															
AISI304	raw	H/38V-80C-BLACK	black															
		H/38V-80C-ANTHR	anthracite	78	37	28				20	135	34	112	250		✓		
		H8/38V-80	-															
Fe	Zn	H/38V-100	-	98	40	32												

new
new
new
new
new
new
new

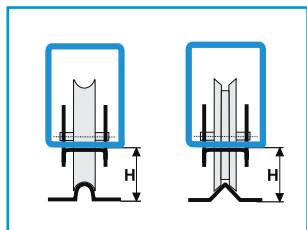

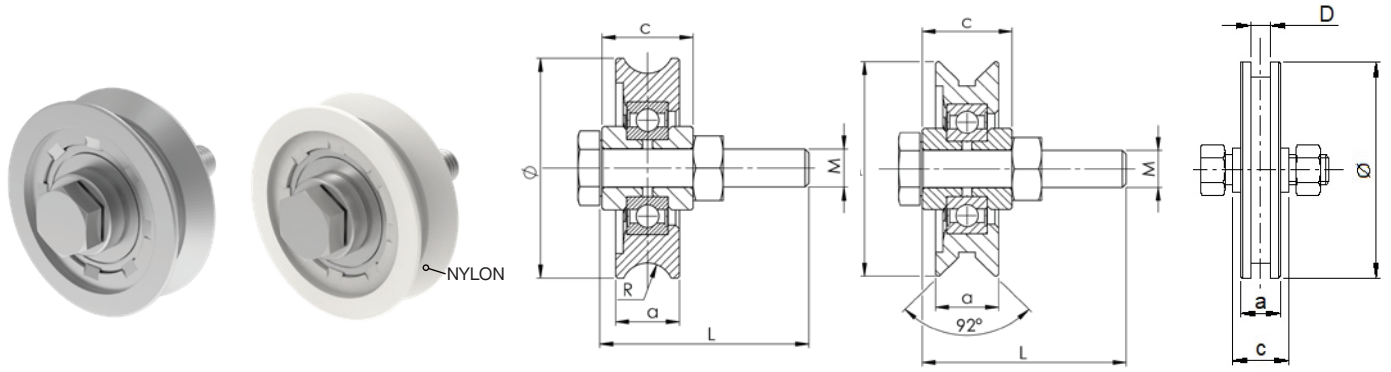

Quality	Finish	art.	Ø	R	D	a	c	L	M	Gmax/2pcs (kg)	
Fe	Zn	H/06U-60	58	8	17	24	27	55	10	200	
AISI304	raw	H8/06U-60-R10-NYLON									
Fe	Zn	H/06U-80	78	8	-	20	28	70	14	300	
AISI304	raw	H8/06U-80-R8									
		H8/06U-80-R10									
		H8/06U-60-R10-NYLON	10	24							
Fe	Zn	H/06U-100	98	8	22	30	70	14	400		
AISI304	raw	H8/06V-60	58	-	17	27	55	10	200		
Fe	Zn	H8/06V-60-NYLON									
AISI304	raw	H8/06V-80	78	-	20	28	70	14	300		
Fe	Zn	H8/06V-80-NYLON									
Fe	Zn	H/06V-100	98	-	22	30	70	14	400		
		H/06V-100-2	100	-	25	30	70	14	700		
		H/06H-50C	50	5	15	27	40	8	120		
		H/06H-80C	78	7	20	28	55	10	300		

new

new

new

new

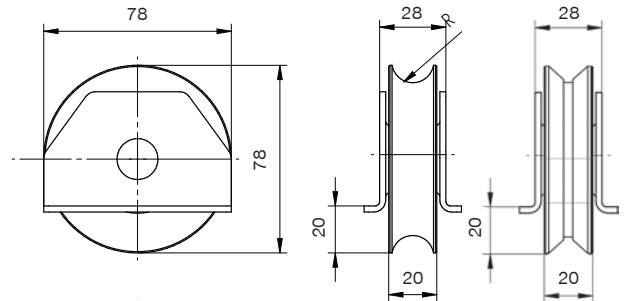
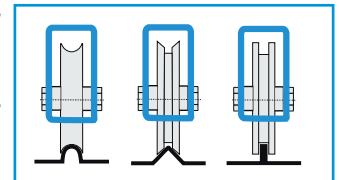

Quality	Finish	art.	R	Gmax/2pcs (kg)	
Fe	Zn	H/49U-80	8	250	
		H/49V-80	-	250	

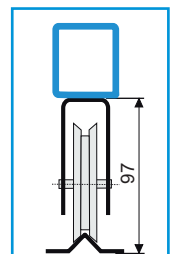
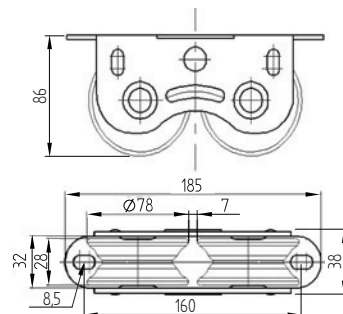
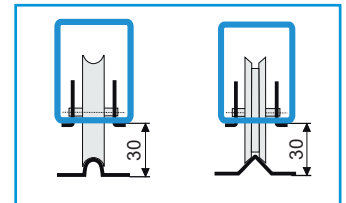

Quality	Finish	art.	Gmax/2pcs (kg)	
Fe	Zn	H/31V-2-80 HEAVY	600	

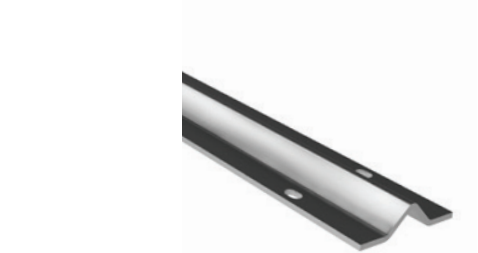

H/39V-...
H8/39V-...

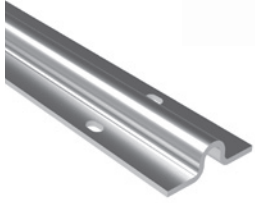

H/39U-...
H8/39U-...

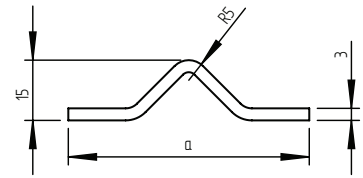
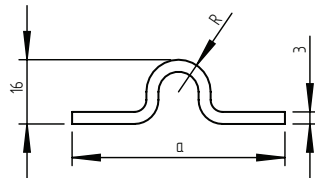
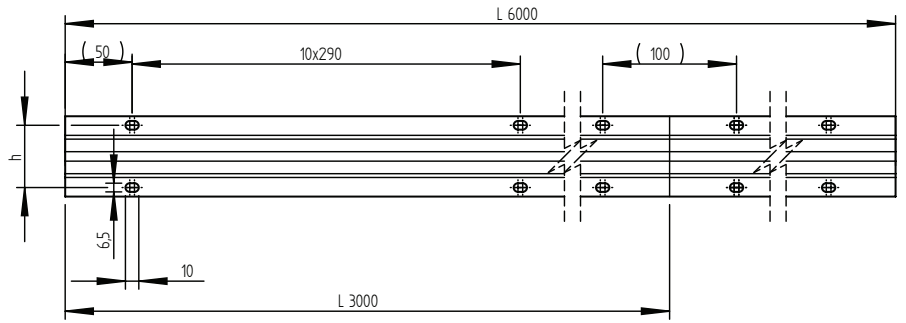

Quality	Finish	art.	a	h	R	L		
Fe	Zn	H/39U-3000	60	46,5	8	3000		
		H/39U-6000				6000		
AISI304	raw	H8/39U-3000	55	40	10	3000	✓	-
		H8/39U-6000				6000		
Fe	Zn	H/39V-3000	60	46,5	5	3000		
		H/39V-6000				6000		
AISI304	raw	H8/39V-3000				3000	-	✓
		H8/39V-6000				6000		

top

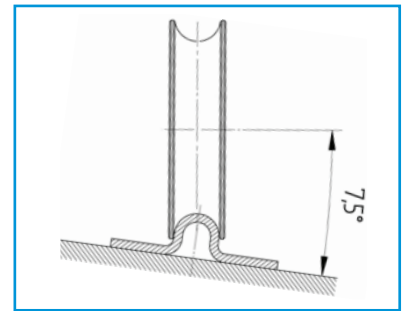

art.	I (V)	P (W)
DEVIIEGUARD 18	230V	18

Vyhrievací kábel/Heating cable

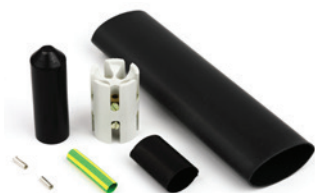
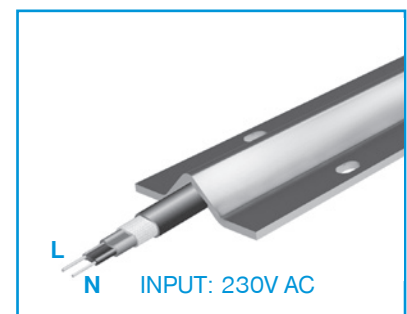

art.
Devi 19400126 <i>new</i>

Spojovacia sada/Connection set

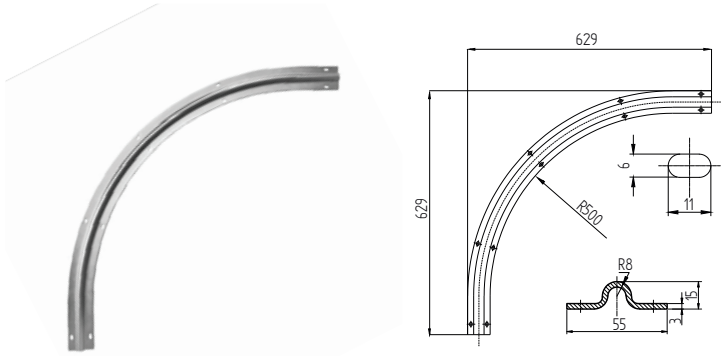

Quality	Finish	art.		
Fe	Zn	H/39U-630-CUR	✓	-

new

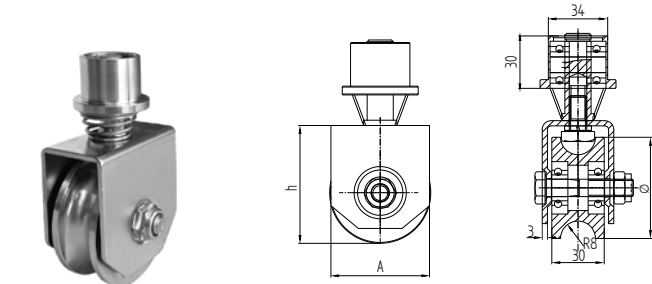
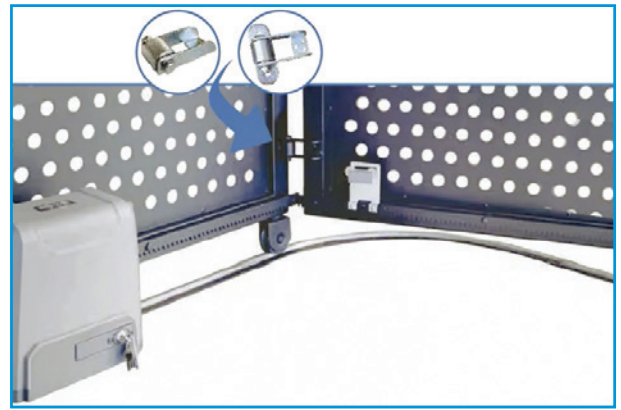

Quality	Finish	art.	∅	h	A		
Fe	Zn	H/31U-60-SP	58	67,5	56,5	✓	-
		H/31U-80-SP	78	87,5	76,5		

new new

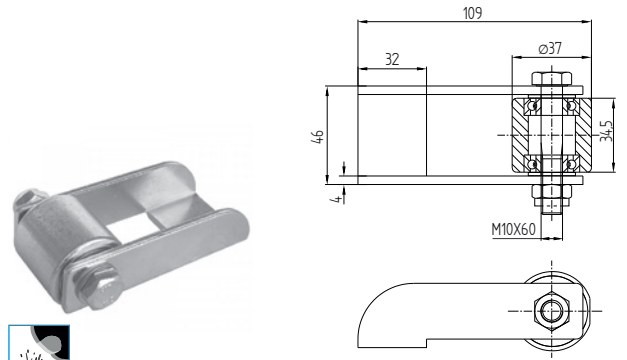

Quality	Finish	art.
Fe	Zn	D4/91-D37

new

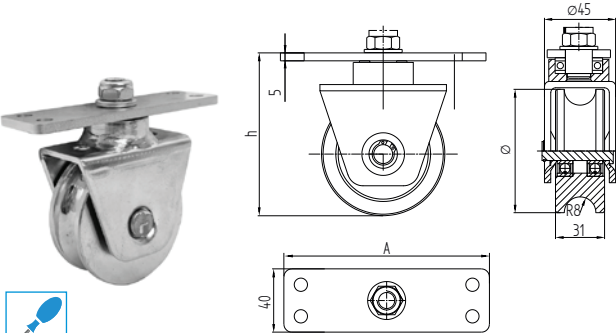

Quality	Finish	art.	∅	h	A		
Fe	Zn	H/31U-60-PL	58	85	100	✓	-
		H/31U-80-PL	78	103	130		

new new

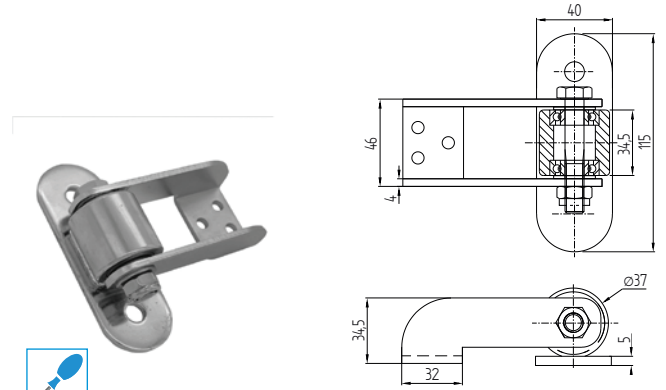

Quality	Finish	art.
Fe	Zn	D4/92-D37

new

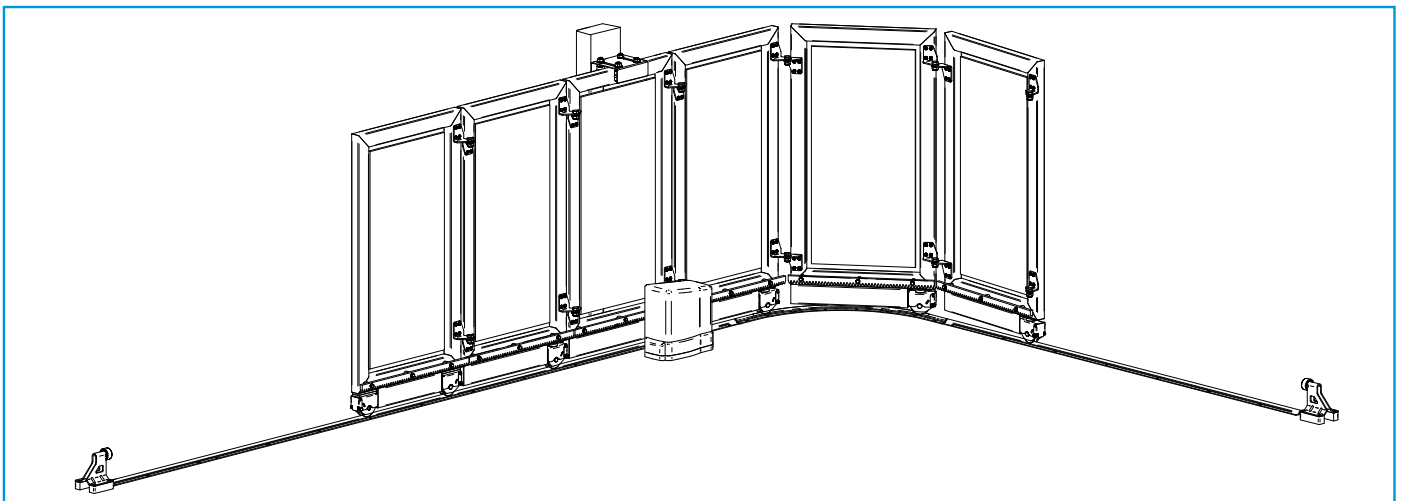

3 POSUVNÉ BRÁNY - PRÍSLUŠENSTVO SLIDING GATES - ACCESORIES



HORNÉ VEDENIA
UPPER GUIDE BRACKETS



DORAZY
STOPPERS



ZÁMKY
LOCKS



HREBENE
RACKS



TELESKOPICKÝ SYSTÉM
TELESCOPIC SYSTEM

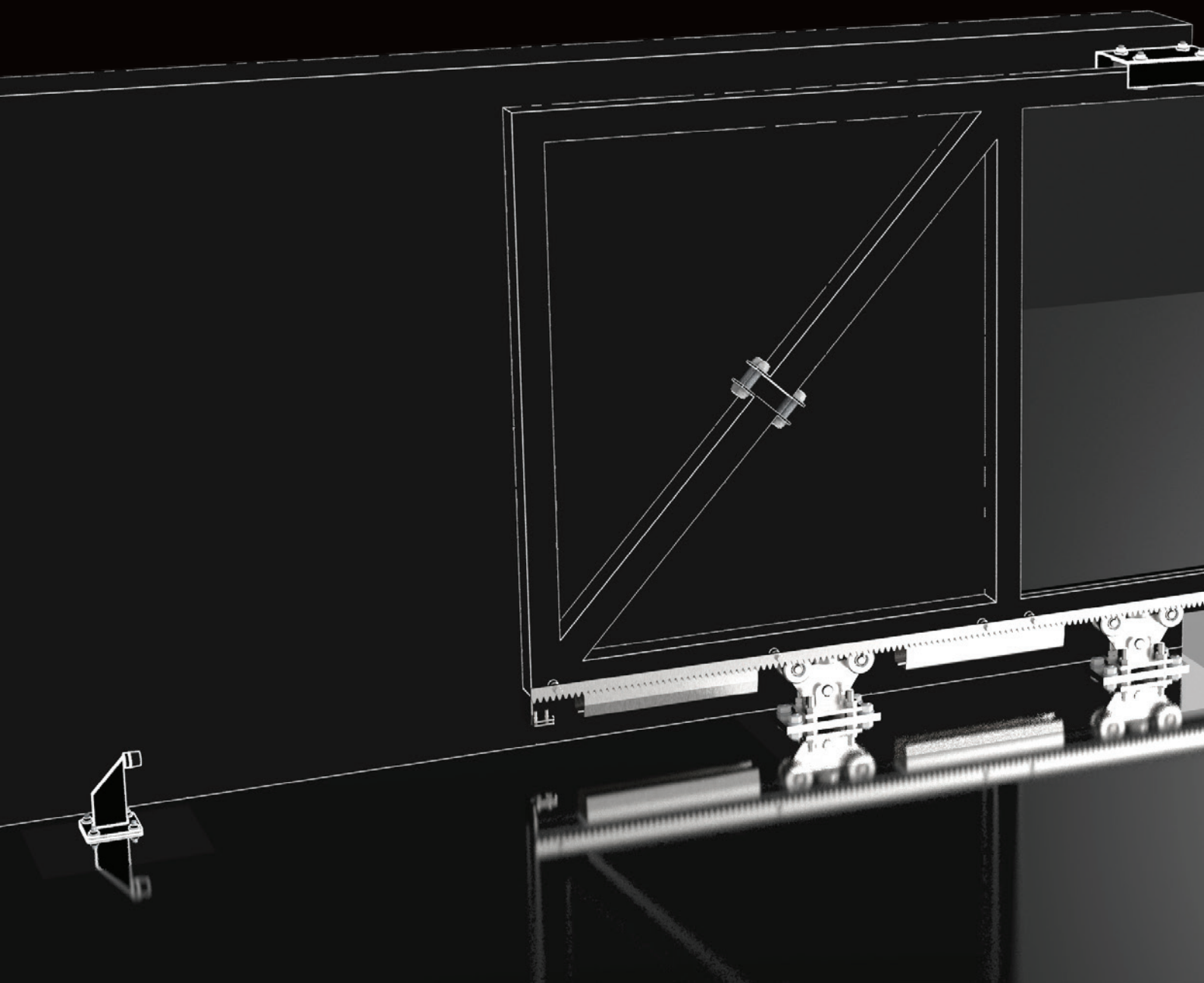

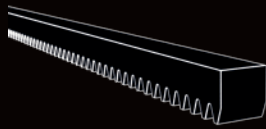
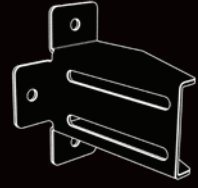
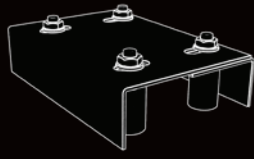

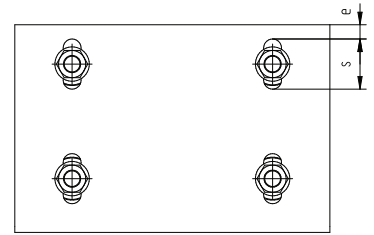
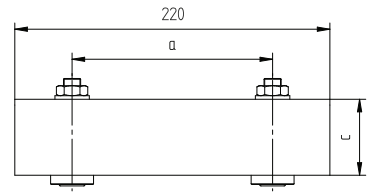
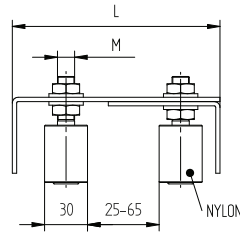
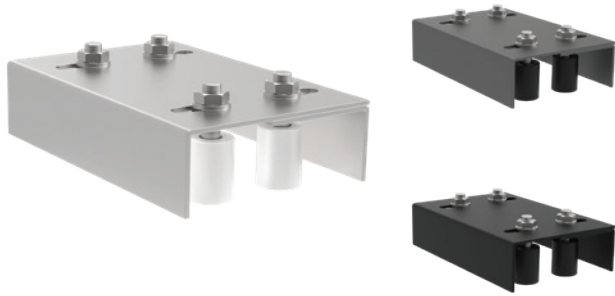

Quality	Finish	art.	Color	L	a	c	e	s	M
Fe	Zn	H/12-4T	-	140-180	140	53	10	35	12
		H/12-4T-BLACK	black						
		H/12-4T-ANTHR	anthracite						
AISI304	raw	H8/12-4T	-	135-175	155	56	16	58	14

*new
new*

UPPER GUIDIE BRACKETS

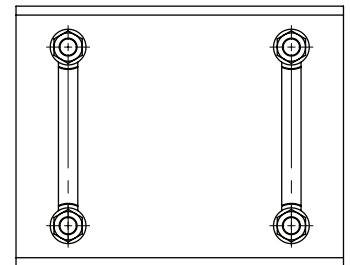
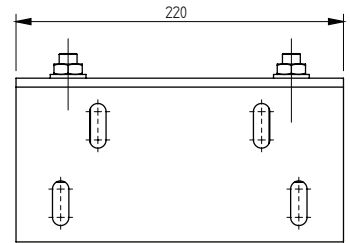
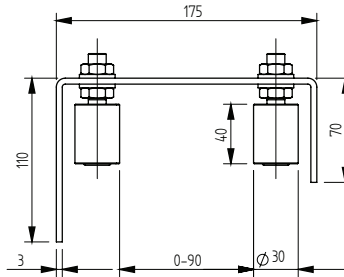

Quality	Finish	art.
Fe	Zn	H/12-4

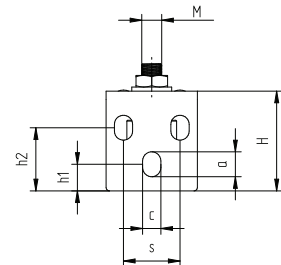
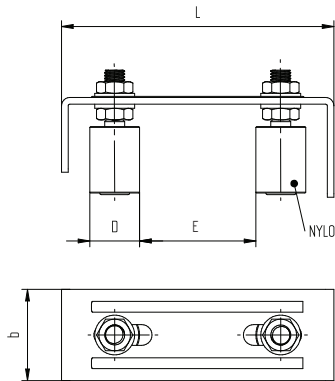

Quality	Finish	art.	Color	L	a	b	c	D	E	h1	h2	H	s	M
Fe	Zn	H/12-2	-	165	-	68	-	41	25-65	-	-	64	-	16
		H/12-2S	-	164	15	57	11	30	35-85	14	36	60	34	12
		H/12-2S-BLACK	black											
		H/12-2S-ANTHR	anthracite											
AISI304	raw	H8/12-2S	-											

*top
new
new*

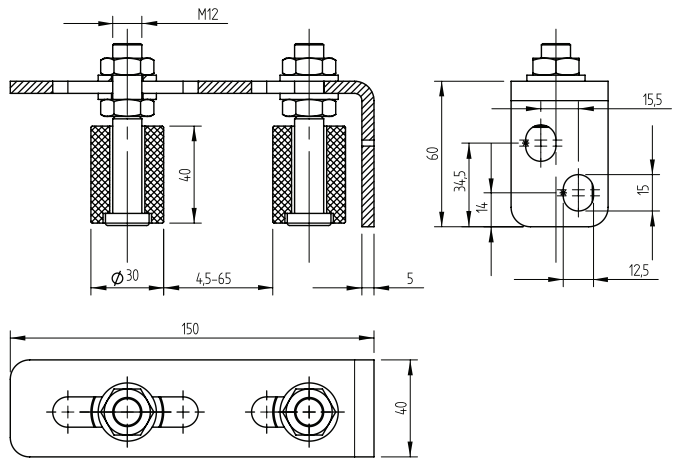
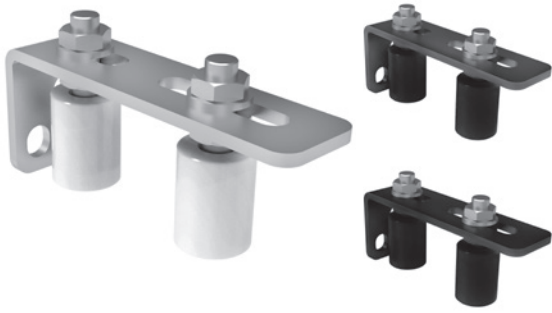

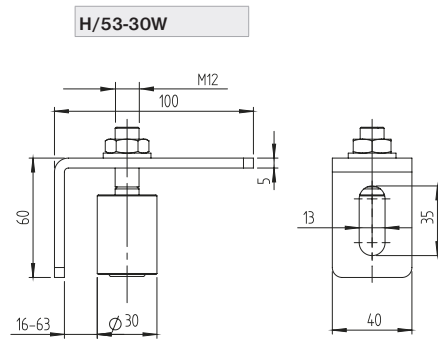
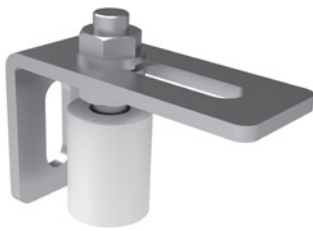

Quality	Finish	art.	Color
Fe	Zn	H/53-2	-
		H/53-2-BLACK	black
		H/53-2-ANTHR	anthracite

*new
new*

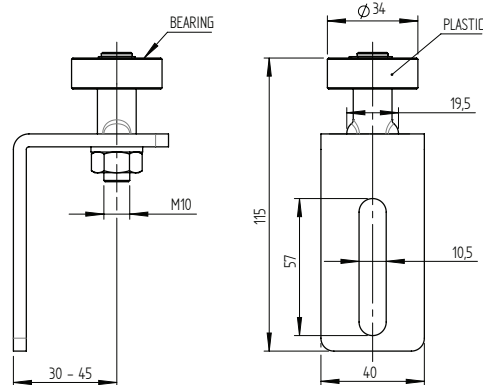
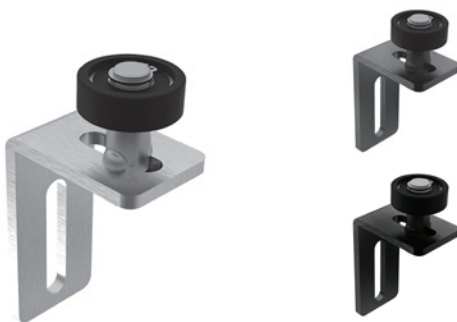

Quality	Finish	art.	
Fe	Zn	H/53-30W	U/40x40



Quality	Finish	art.	Color	
Fe	Zn	H/53	-	U/40x40
		H/53-BLACK	black	
		H/53-ANTHR	anthracite	
AISI304	raw	H8/53	-	

*top
new
new*



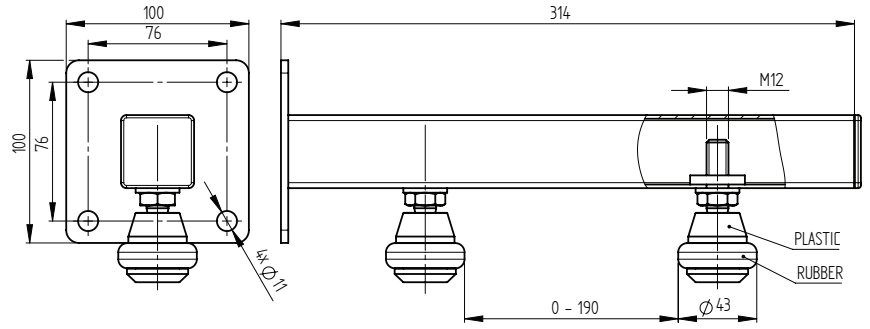

Quality	Finish	art.
Fe	Zn	H/52-2

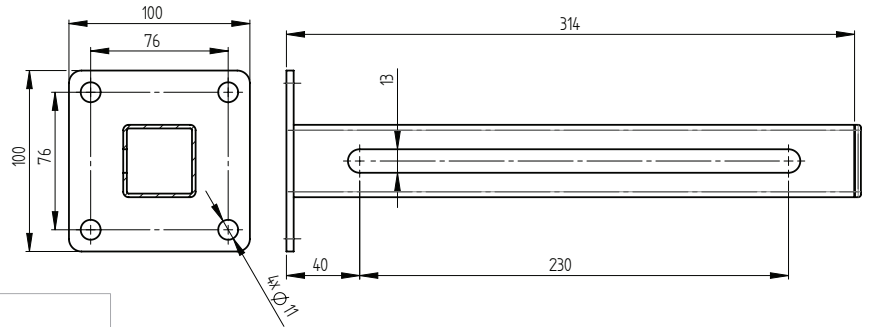
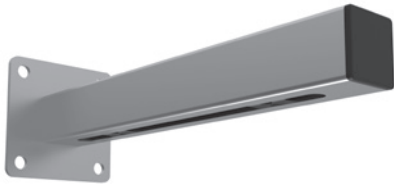

Quality	Finish	art.	
Fe	Zn	H/52-40x40	
AISI304	raw	H8/52-40x40	
			H/04-25-W, H/04-32-W, H8/04-22-W, H/04-30-B, H/04-30-W, H/04G-43, H8/04-32-W

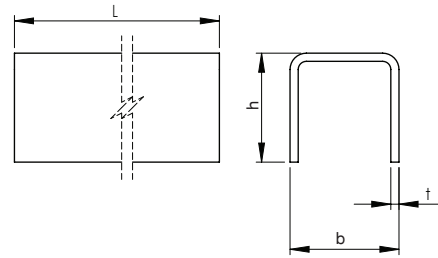
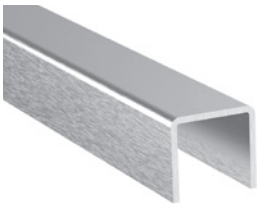

Quality	Finish	art.	bxh	t	L	
AISI304	raw	A/6900-020	28x26	2	2500	H8/04-22-W
		A/U40x40x3-3M			3000	
		A/U40x40x3-6M			6000	H/04-30...
Fe	natural	U/40x40x3-3M	40x40		3000	H/04-32-W
		U/40x40x3-6M			3000	H8/04-32-W
		AL/U40x40x3-6M			6000	
AISI304	raw	A/U50x50x3-3M		3	3000	
		A/U50x50x3-6M			6000	H/04-42...
		U/50x50x3-3M	50x50		3000	H/04G-43
Fe	natural	U/50x50x3-6M			3000	H/04L-42
ALUMINIUM		AL/U50x50x3-6M			6000	

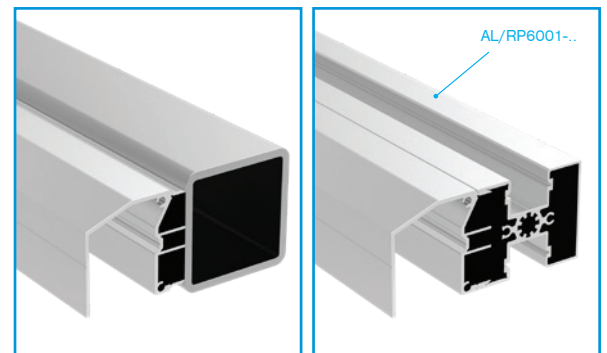
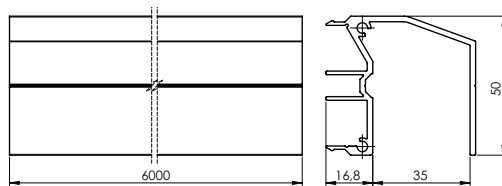

new
new
new
new
new
new



Quality	Finish	art.	
ALUMINIUM	natural	AL/RP-6005-6000-N	H8/04-32-W, H8/04L-35

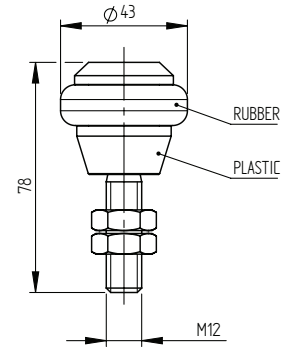

new



Quality	Finish	art.		
Fe	Zn	H/04G-43	-	U/50x50
AISI304	raw	H8/04G-43	-	U/50x50

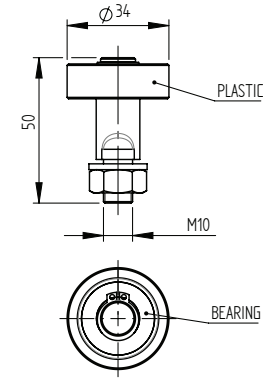

top new

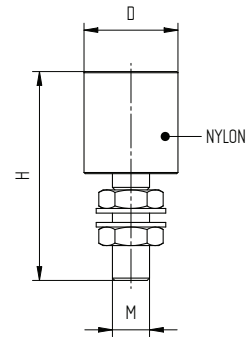

Quality	Finish	art.		
Fe	Zn	H/04L-35	-	U/40x40
AISI304	raw	H8/04L-35	✓	AL/RP-6005-6000-N

new



Quality	Finish	art.	Color		D	H	M	
AISI304	raw	H8/04-22-W	White	-	22			A/6900-020
		H/04-25-W	White	-	25			-
Fe	Zn	H/04-30-W	White	-	30	75	12	U/40x40
		H/04-30-B	Black	-	30	75	12	U/40x40
		H/04-32-W	White	-	32			
AISI304	raw	H8/04-32-W	White	-	32			AL/RP-6005-6000-N
Fe	Zn	H/04L-40-W	White	✓	40			
		H/04-42-W	White	-	41	90	16	U/50x50
		H/04-42-B	Black	-	41	90	16	U/50x50

top top

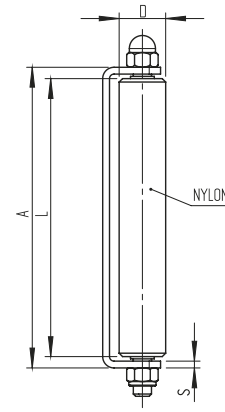

Quality	Finish	art.	Nylon Color	A	D	L	M	s
Fe	Zn	H/21-76W	White	95	62	76	1/2"	5
		H/21-152W		168		152		
		H/21-250W		265		250		
		H/21-305B	Black	320	66	305	1/2"	5
		H/21-305W	White					

*new
new*

UPPER GUIDIE
BRACKETS

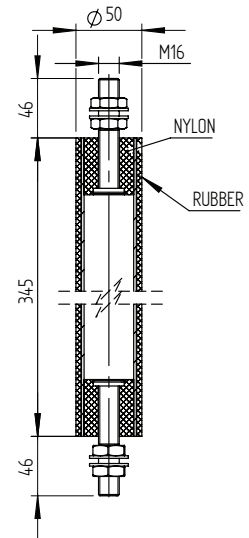

Quality	Finish	art.
Fe	Zn	H/29-V

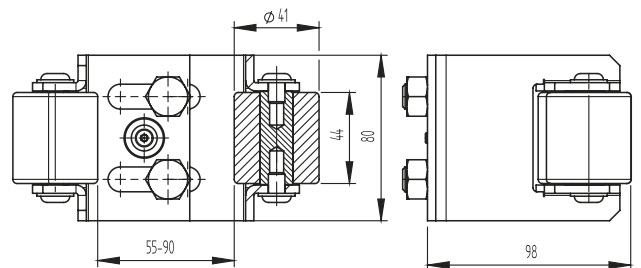

Quality	Finish	art.
Fe	Zn	H/37-55-90

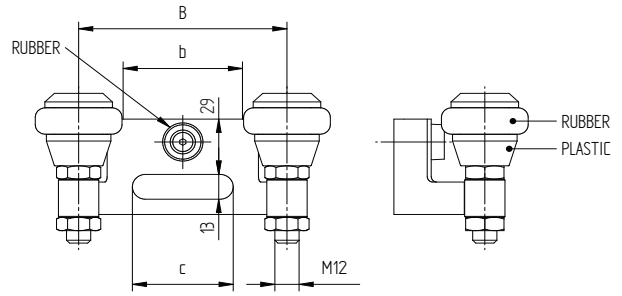

Quality	Finish	art.	Color	b	c	B
Fe	Zn	H/37-40P	-	40	50	83
		H/37-40P-BLACK	black			
		H/37-40P-ANTHR	anthracite			
AISI304	raw	H8/37-40P	-	60	50	103
Fe	Zn	H/37-60P	-			
		H/37-60P-BLACK	black			
		H/37-60P-ANTHR	anthracite			
AISI304	raw	H8/37-60P	-	80	60	123
Fe	Zn	H/37-80P	-			

*top
new
new*

*new
new*

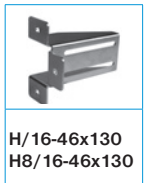

H/16-46x130
H8/16-46x130

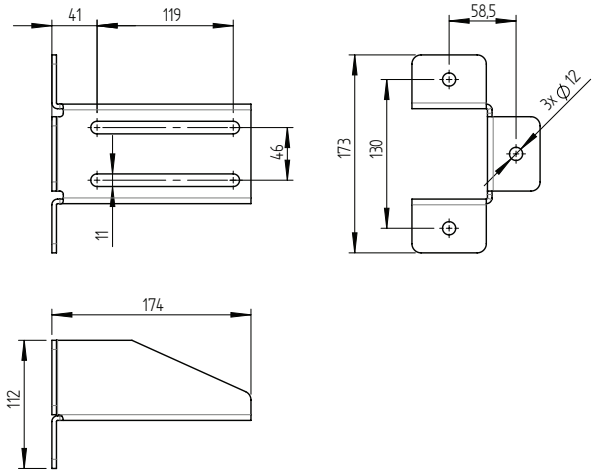

Quality	Finish	art.	Color
Fe	Zn	H/16-46x130	-
		H/16-46x130-BLACK	black
		H/16-46x130-ANTHR	anthracite
AISI304	raw	H8/16-46x130	-

*new
new*

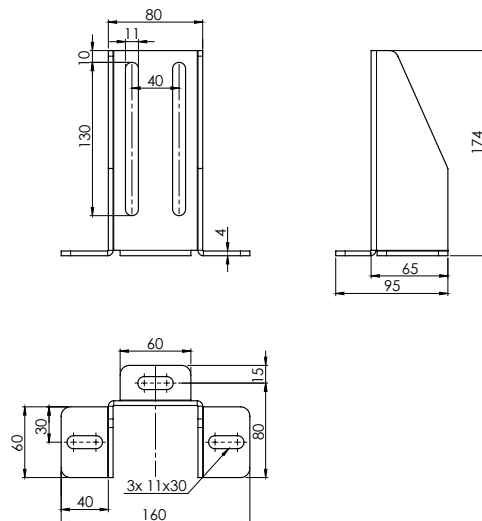

Quality	Finish	art.
Fe	Zn	H/16-40x130-S

new

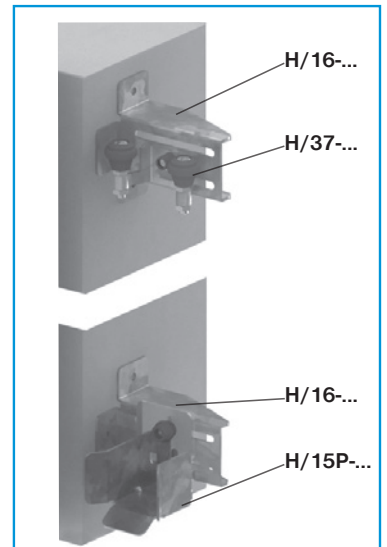

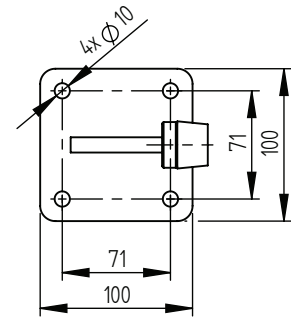
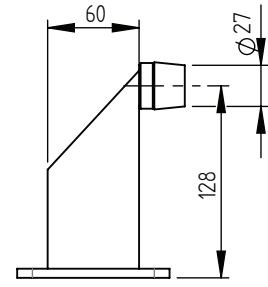

Quality	Finish	art.	Color
		H/10B-60x130	-
Fe	Zn	H/10B-60x130-BLACK	black
		H/10B-60x130-ANTHR	anthracite
AISI304	raw	H8/10B-60x130	-

new
new

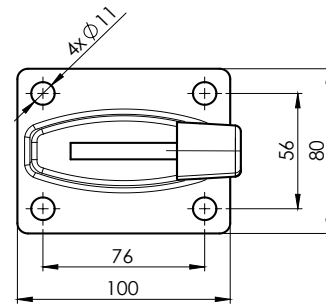
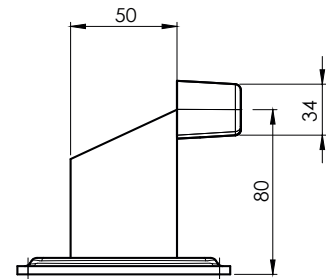
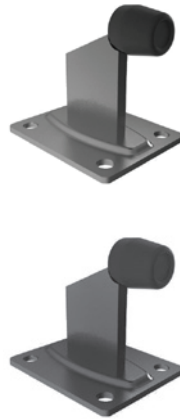

Quality	Finish	art.	Color
		H/10B-50x80	-
Fe	Zn	H/10B-50x80-BLACK	black
		H/10B-50x80-ANTHR	anthracite

new
new

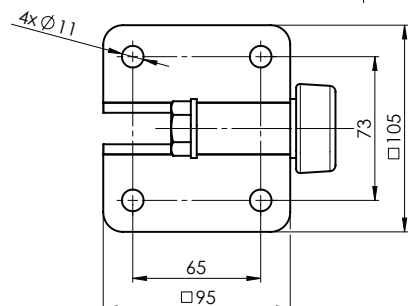
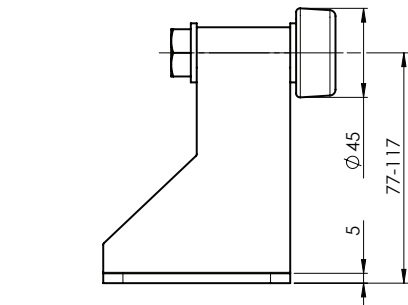

Quality	Finish	art.
Fe	Zn	H/10B-50x120

new

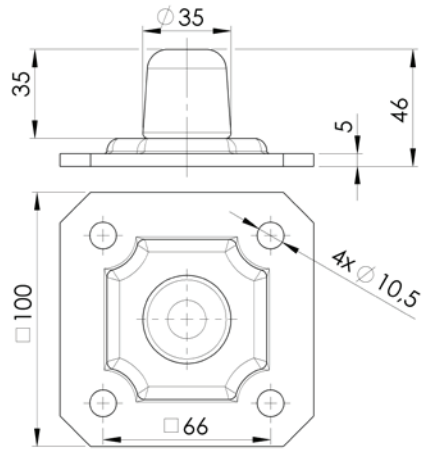
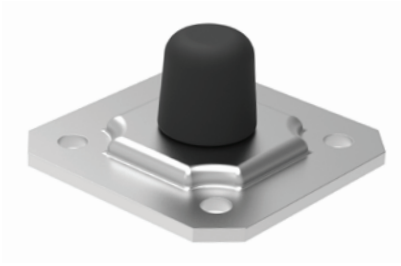

Quality	Finish	art.
Fe	Zn	H/10B-35x46 <i>new</i>

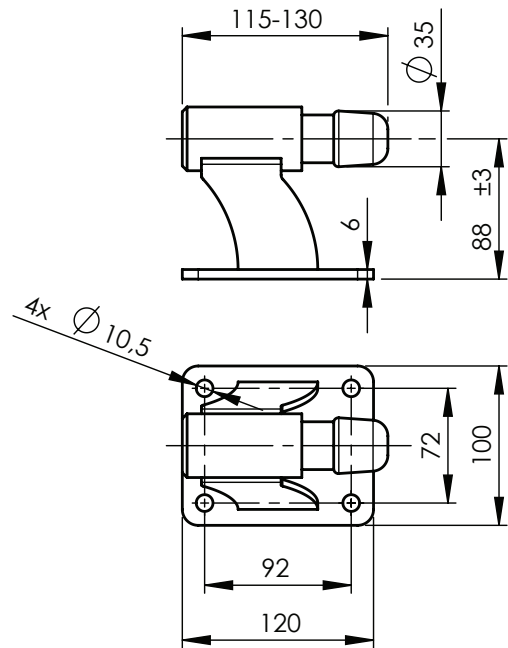

Quality	Finish	art.
Fe	Zn	H/10B-130x85-SPRING <i>new</i>

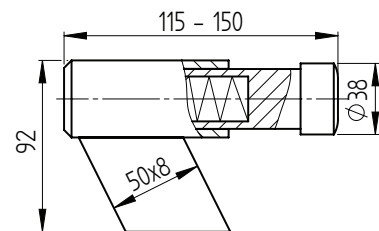
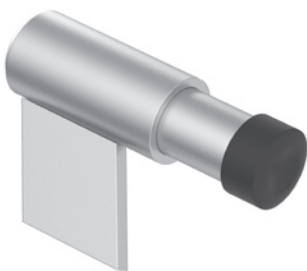

Quality	Finish	art.
Fe	Zn	H/10BP-150x92-SPRING <i>new</i>



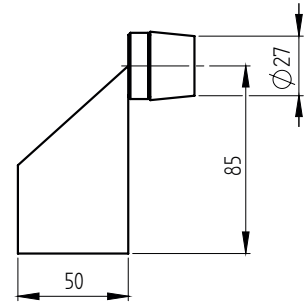

Quality	Finish	art.
Fe	Zn	H/10BP-50x100

STOPPERS

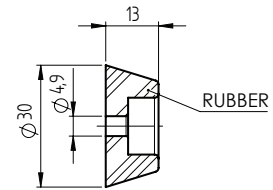

Quality	Finish	art.
Rubber	black	B1/16G

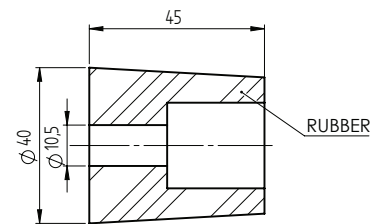



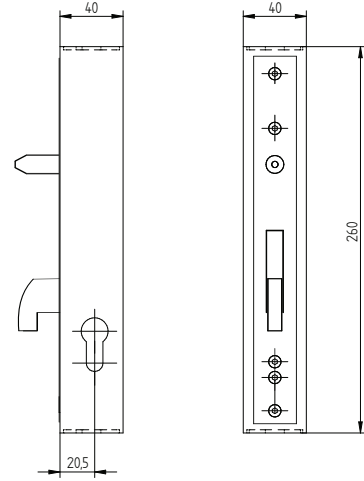

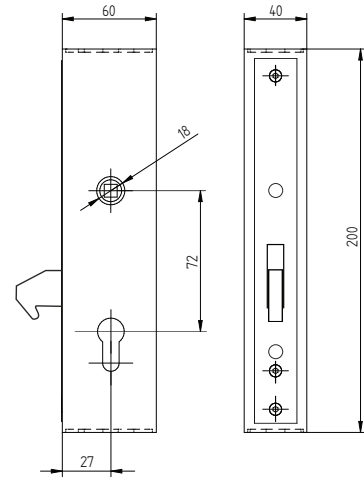

Quality	Finish	art.
Rubber	black	B1/16G-B



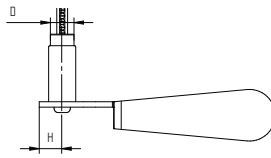

Quality	Finish	art.
Fe	raw	H/46-40x40

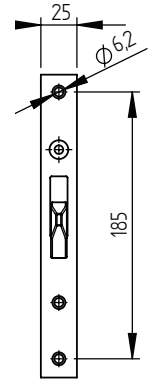
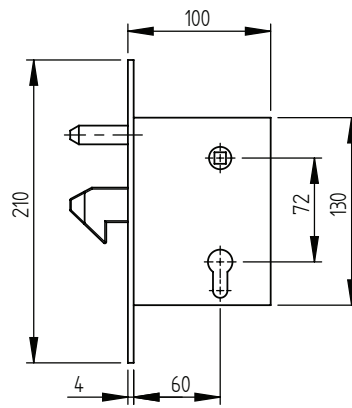

Quality	Finish	art.
Fe	raw	H/46-60x40

	  								
	D	-	-	-	D17	D17	D19	-	19
Hmax	26	15	18	15	17	17	15	30	35
Model	K01	K02	K03	K11	K12	K13	K21	K22	K23
H/35K		✓					✓		
H/36-30K		✓	✓	✓	✓		✓		
H/36-40K	✓	✓	✓	✓	✓		✓		
H/36-20K		✓					✓		
H8/36-20K		✓					✓		
H/46-40x40							✓		
H/46-60x40		✓	✓	✓	✓		✓		



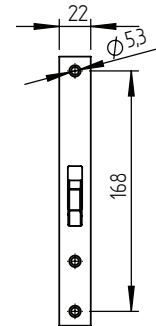
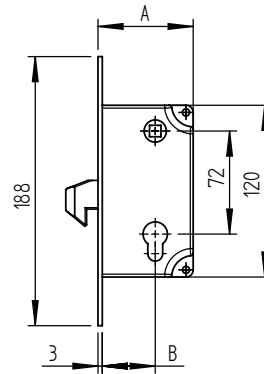

Quality	Finish	art.	
Fe	Zn	H/35-64A	H/35-K

LOCKS

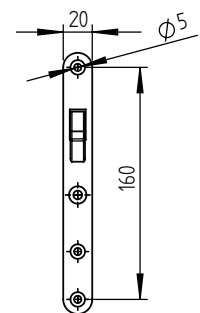
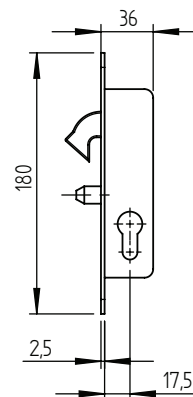

Quality	Finish	art.	A	B	
Fe	Zn	H/36-30A	56	27	H/36-30K
		H/36-40A	66,5	37	H/36-40K



Quality	Finish	art.	
Fe	Zn	H/36-20A	H/36-20K H8/36-20K

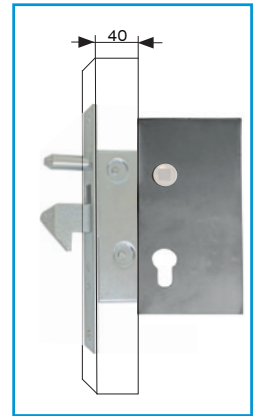
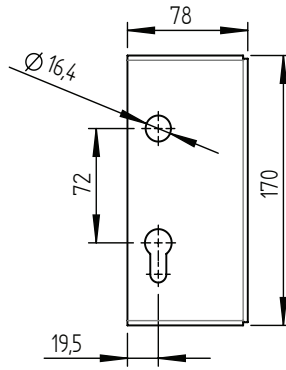
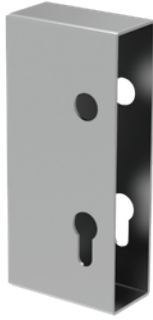

Quality	Finish	art.
Fe	Zn	H/35-K

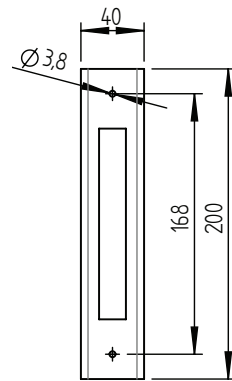
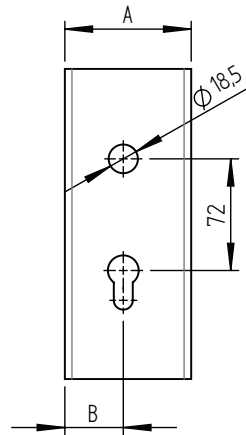

Quality	Finish	art.	A	B
Fe	raw	H/36-30K	60	27
		H/36-40K	80	37

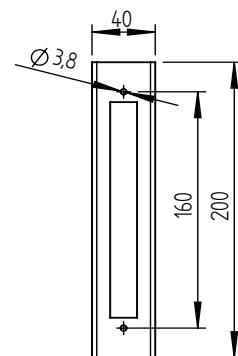
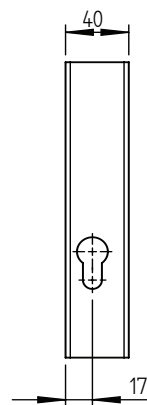

Quality	Finish	art.
Fe	raw	H/36-20K
AISI304	satin	H8/36-20K

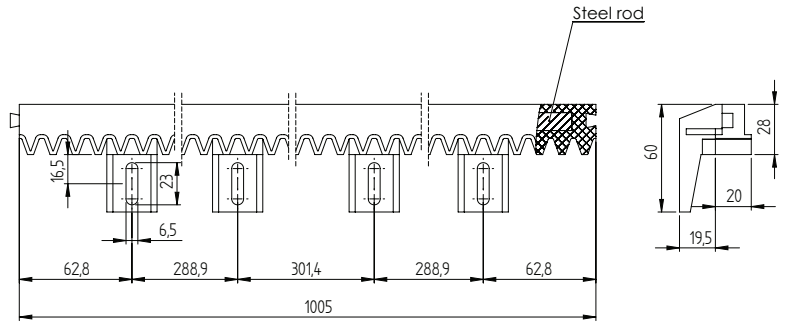
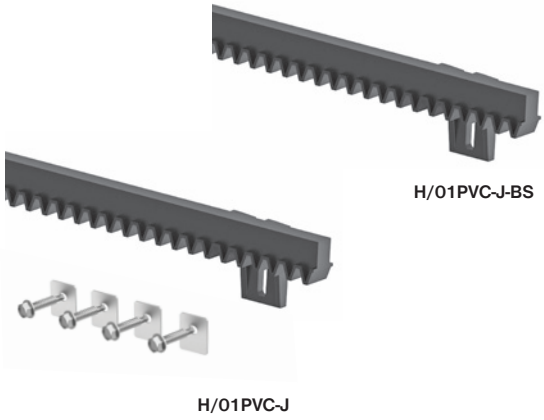

Quality	Finish	art.	Module	Gmax (kg)	H/01PVC-J-BS	H/01PVC-FS-J
PVC	raw	H/01PVC-J-BS	4	300	1x	-
		H/01PVC-J			2x	1x
		H/01PVC-J-2PACK			2x	2x

top
new

RACKS

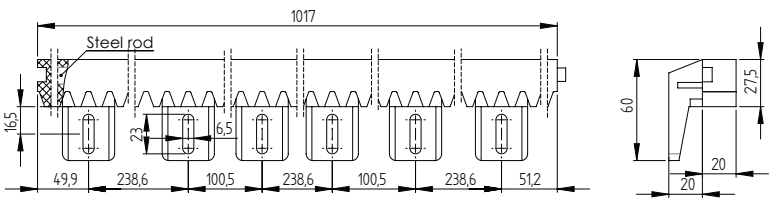
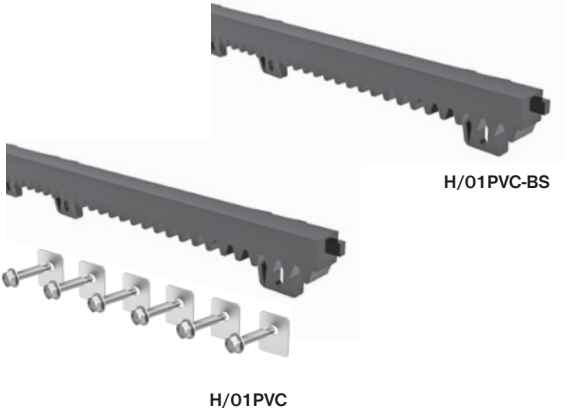

Quality	Finish	art.	Module	Gmax (kg)	H/01PVC-J-BS	H/01PVC-FS-J
PVC	raw	H/01PVC-BS	4	300	1x	-
		H/01PVC			2x	1x
		H/01PVC-2PACK			2x	2x

new

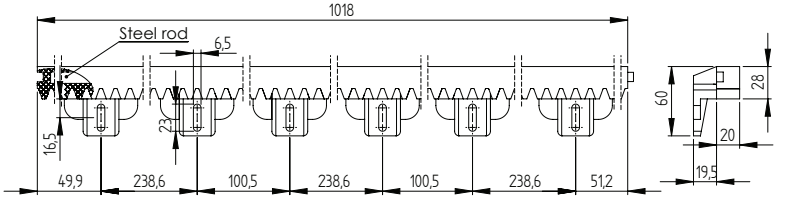
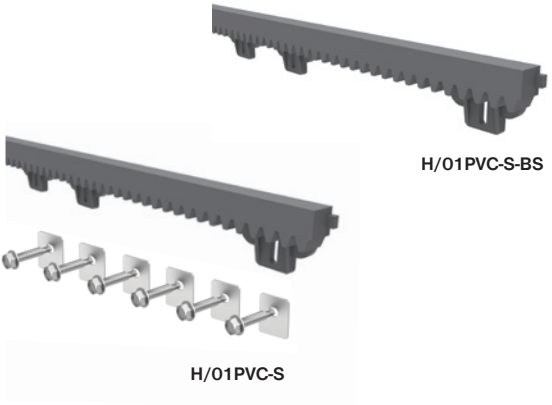

Quality	Finish	art.	Module	Gmax (kg)	H/01PVC-FS
PVC	raw	H/01PVC-S-BS	4	1200	-
		H/01PVC-S			1x

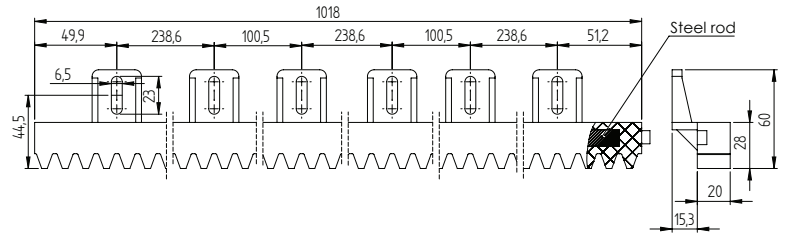
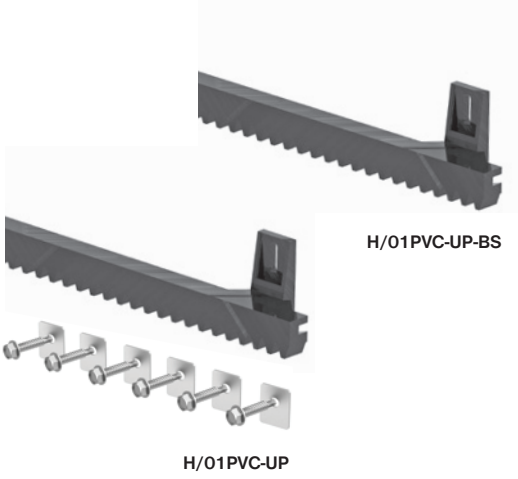

Quality	Finish	art.	Module	Gmax (kg)	H/01PVC-FS
PVC	raw	H/01PVC-UP-BS	4	700	-
		H/01PVC-UP			1x

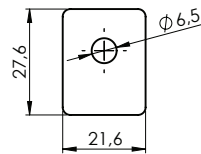

Quality	Finish	art.
Fe	Zn	H/01PVC-FS
		H/01PVC-FS-J <i>new</i>

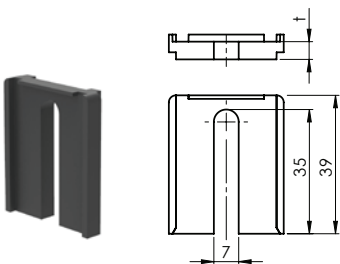

Quality	Finish	art.	t	package includes
PVC	raw	A19/01PVC-05	5	6 pcs <i>new new</i>
		A19/01PVC-10	10	

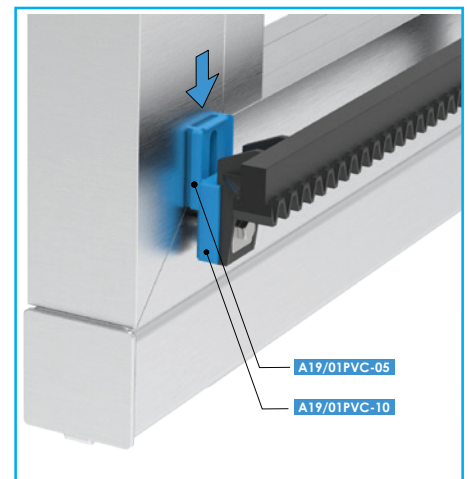
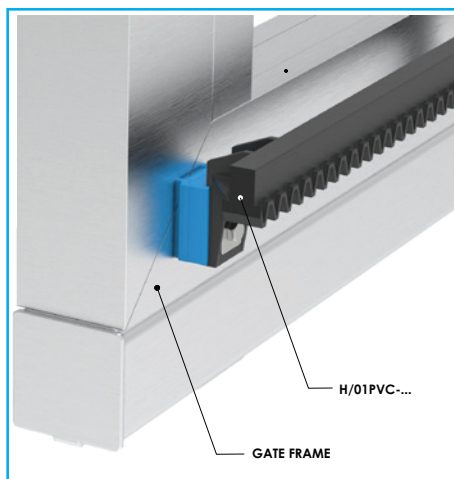

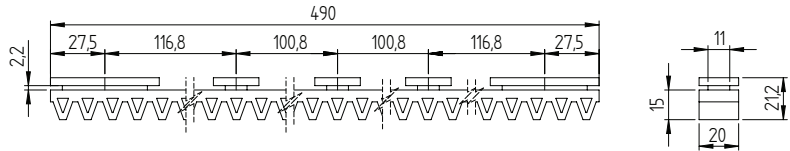
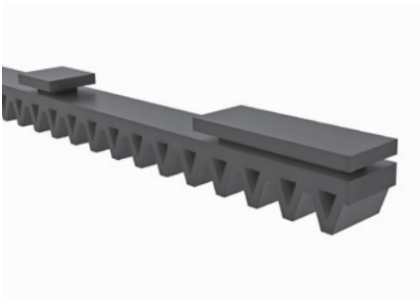

Quality	Finish	art.	Gmax (kg)
NYLON	raw	H/01PVC-AL	300

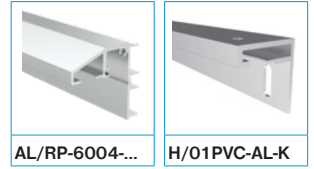

RACKS

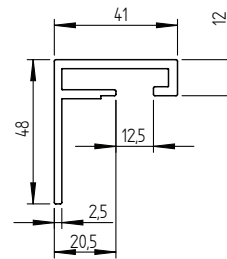
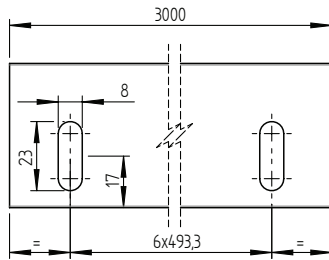
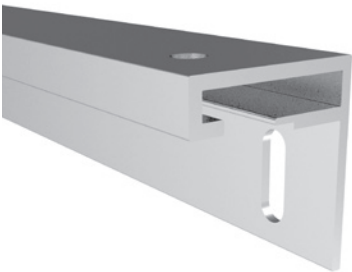

Quality	Finish	art.
ALUMINIUM	natural	H/01PVC-AL-K



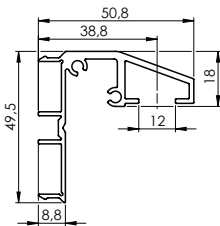
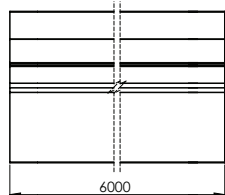
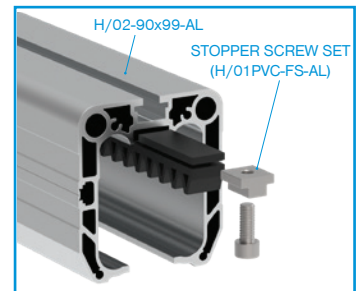

Quality	Finish	art.
Fe	Zn	H/01PVC-FS-AL <i>new</i>

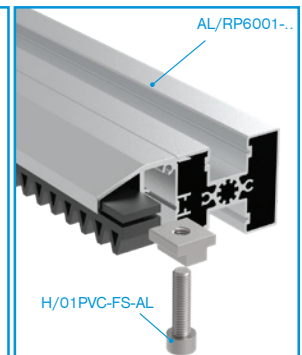
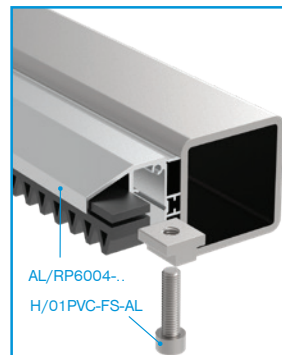

Quality	Finish	art.
ALUMINIUM	natural	AL/RP-6004-6000-N <i>new</i>

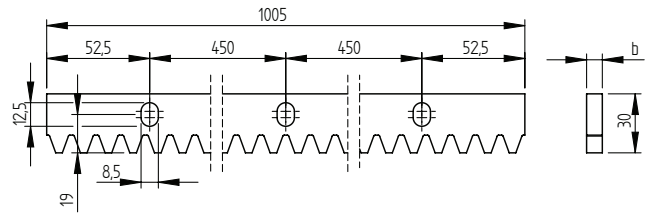



Quality	Finish	art.	Module	h x b	Gmax (kg)	
Fe	Zn	H/01Fe-30x8H	4	30x8	1200	3x
AISI304	raw	H8/01-30x8H		30x10	1500	
Fe	Zn	H/01Fe-30x10H		30x12	1700	
		H/01Fe-30x12H				

top

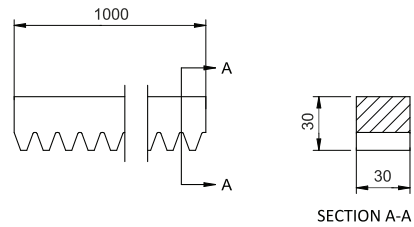

Quality	Finish	art.	Module	Gmax (kg)
Fe	Zn	H/01Fe-30x30H	6	5000

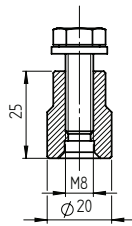

Quality	Finish	art.
Fe	Zn	H/32
AISI304	raw	H8/32

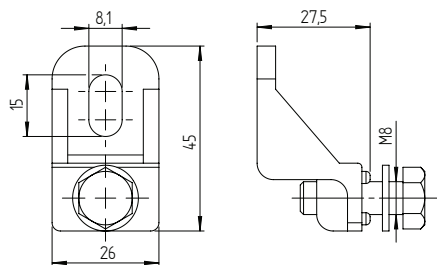
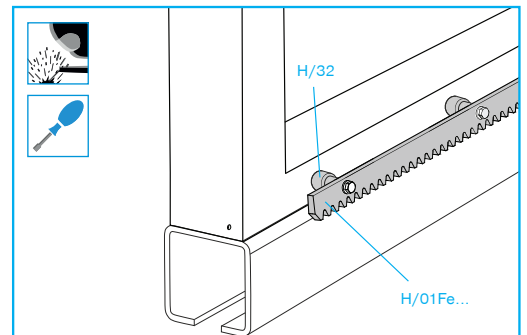

Quality	Finish	art.
Fe	Zn	H/33

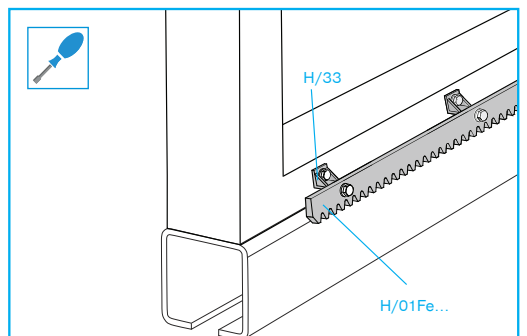

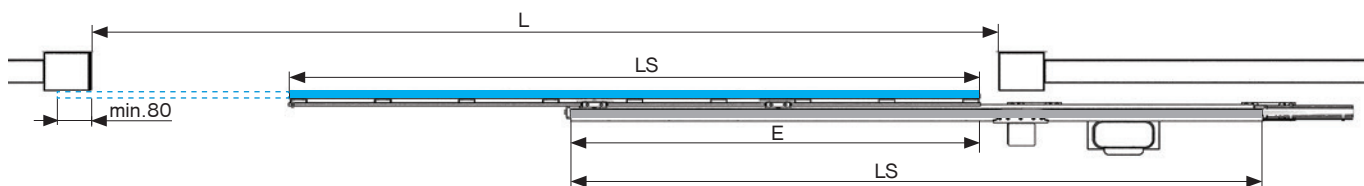
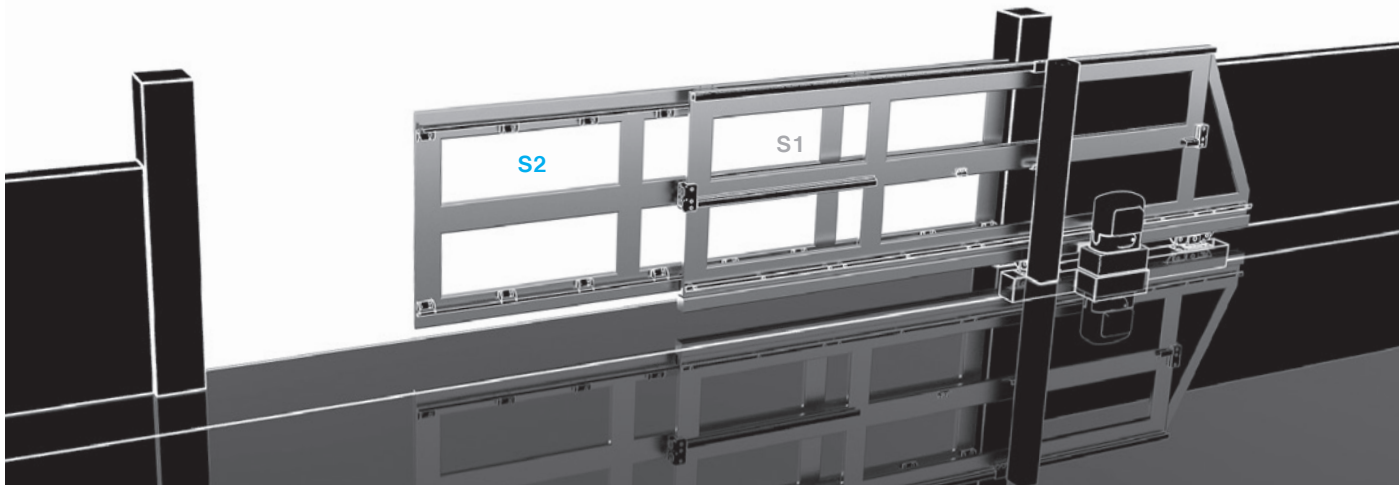

TELESCOPIC GATES

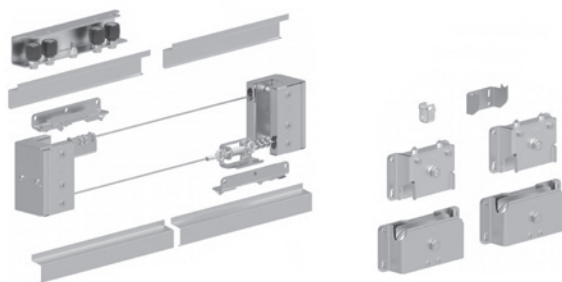

SV...



H/10B...



U/40x40x3-
A/U40x40x3-
AL/U40x40x3-..



A/20-6000



H/37...

Quality	Finish	art.	max L	TS-CS8-ECO	LV-2C8-250-ECO
Fe	Zn	TS-C2-8	8000	1x	1x

L	LS	E	max S2 (kg)
3500	2690	900	250
4000	3060	1020	
4500	3440	1150	
5000	3810	1270	
5500	4190	1400	
6000	4560	1520	
6500	4940	1650	
7000	5310	1770	
7500	5690	1900	
8000	6060	2020	

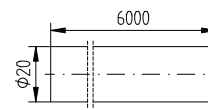
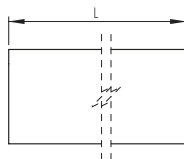
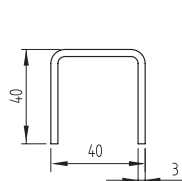
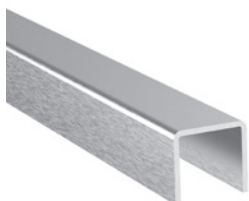

Quality	Finish	art.	L
Fe	raw	U/40x40x3-3M	3000
		U/40x40x3-6M	6000
ALSI304	natural	A/U40x40x3-3M	3000
		A/U40x40x3-6M	6000
ALUMINIUM	natural	AL/U40x40x3-6M	6000

new
new
new

Quality	Finish	art.
ALSI304	raw	A/20-6000



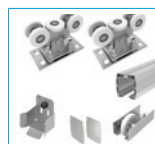
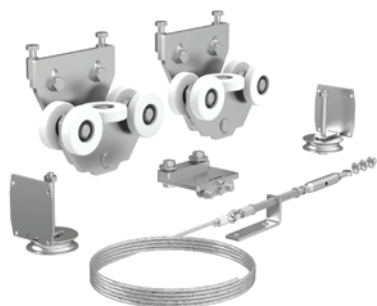
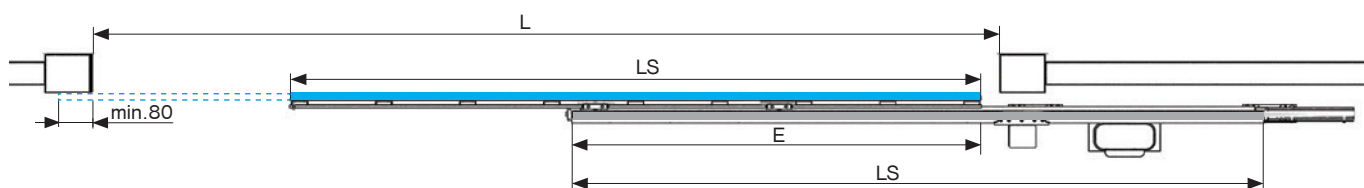
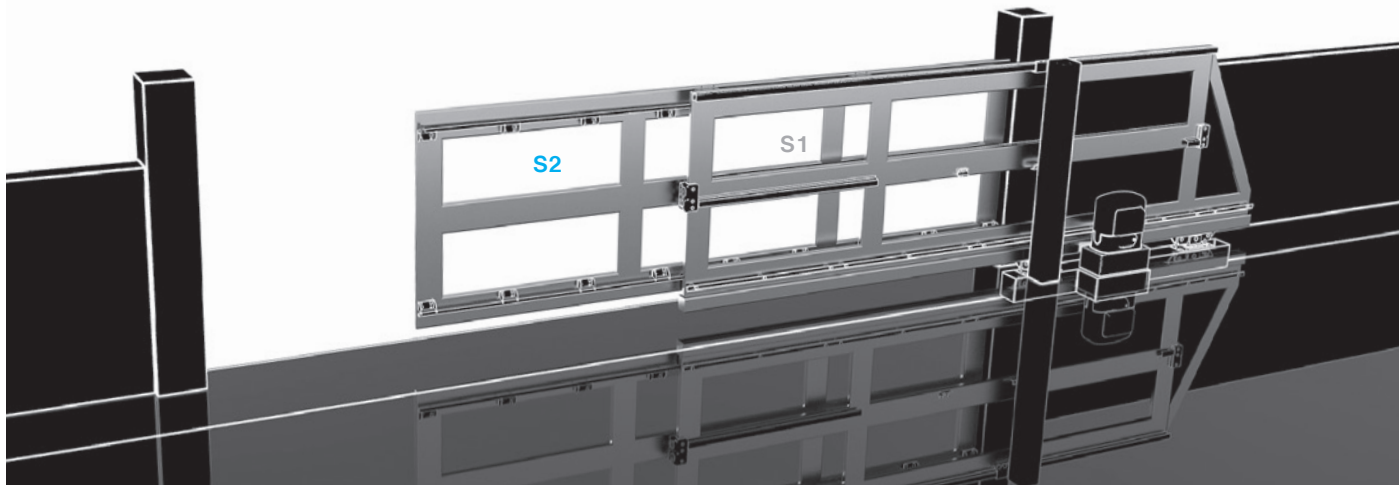

SV-90x95-AL



H/02-90x95...



H8/12...



H8/37...



H8/10B...

Quality	Finish	art.	max L
ALUMINIUM	natural	TS-C2-8-AL	8000

new

SOON

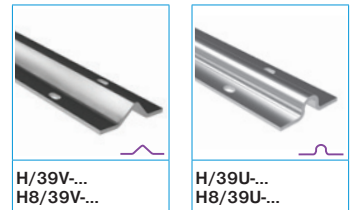
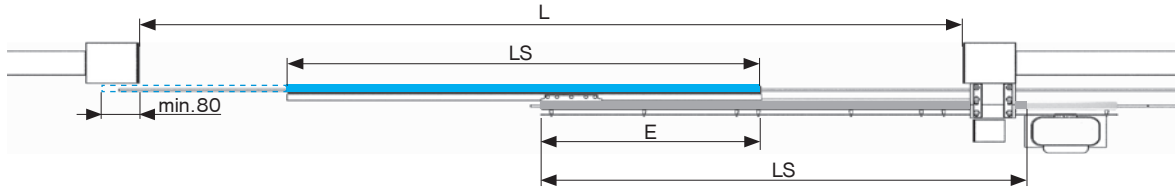
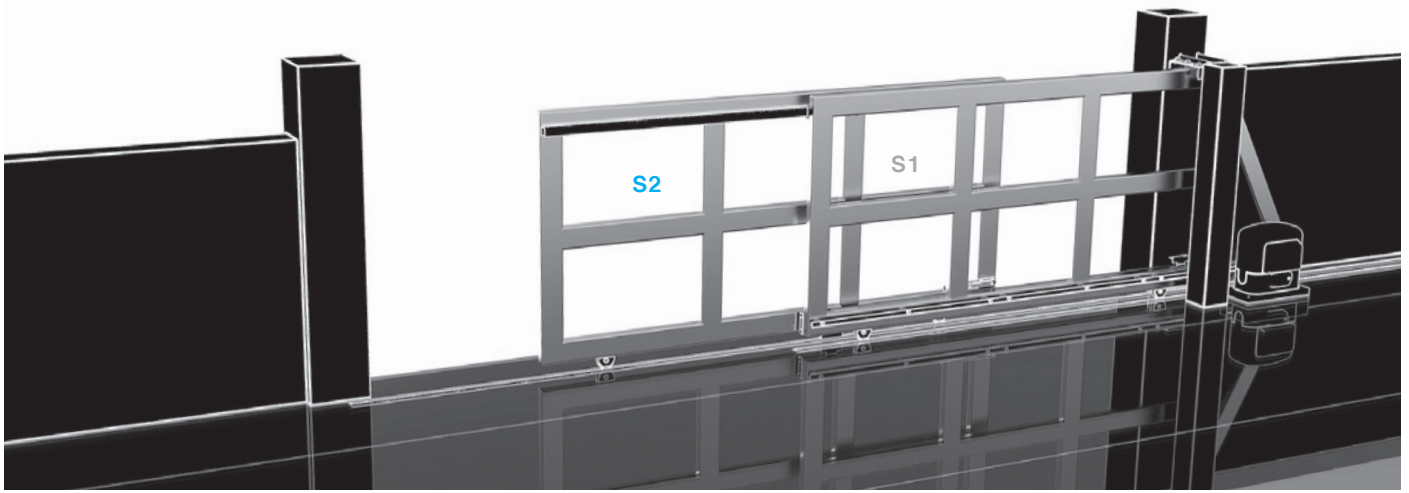

Quality	Finish	art.	max L
Fe	Zn	TS-S2-4-N	4000
		TS-S2-8-N	8000
		TS-S2-15-N	15000

*new
new
new*

L	LS	min E	max S2 (kg)
3000	1890		
4000	2390		
5000	2890		
6000	3390	350	300
7000	3890		
8000	4390		
9000	5140		
10000	5640		
11000	6140		
12000	6640	600	400
13000	7140		
14000	7640		
15000	8140		

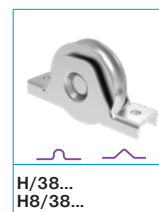
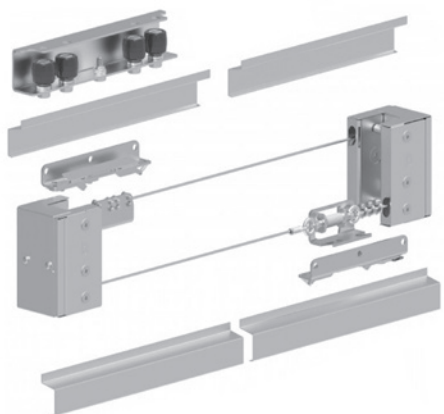
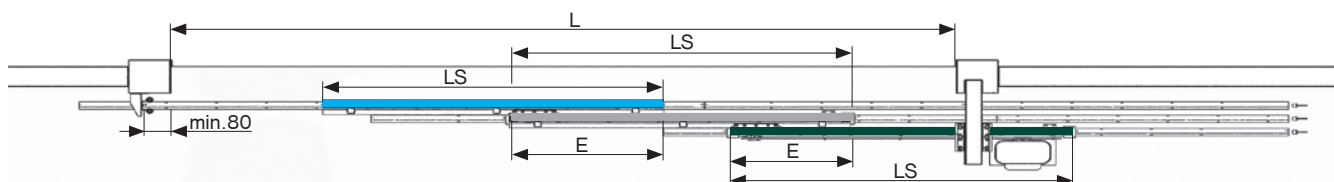
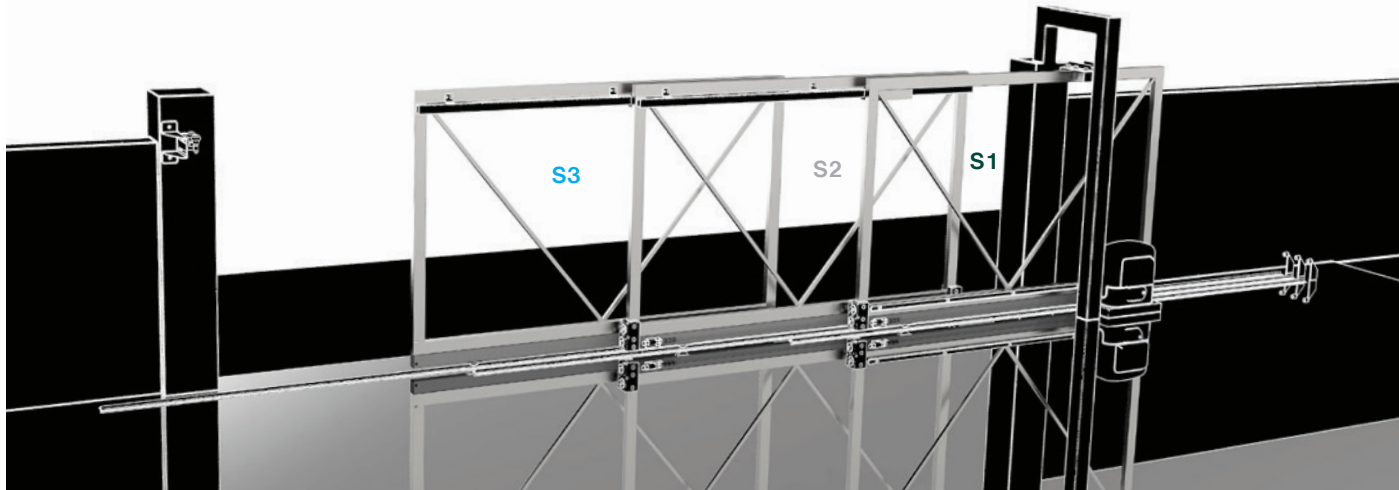

Quality	Finish	art.	max L	TS-CS8-ECO
Fe	Zn	TS-S3-15	15000	2x

L	LS	min E	max S2, S3 (kg)
3000	1380		
4000	1710		
5000	2040		
6000	2380	350	
7000	2710		
8000	3040		
9000	3630		200
10000	3960		
11000	4290		
12000	4630	600	
13000	4960		
14000	5290		
15000	5630		

4 ZÁVESNÉ BRÁNY HANGING GATES



PROFILY, VOZÍKY
TRACKS, CARRIAGES



PRÍSLUŠENSTVO
ACCESSORIES

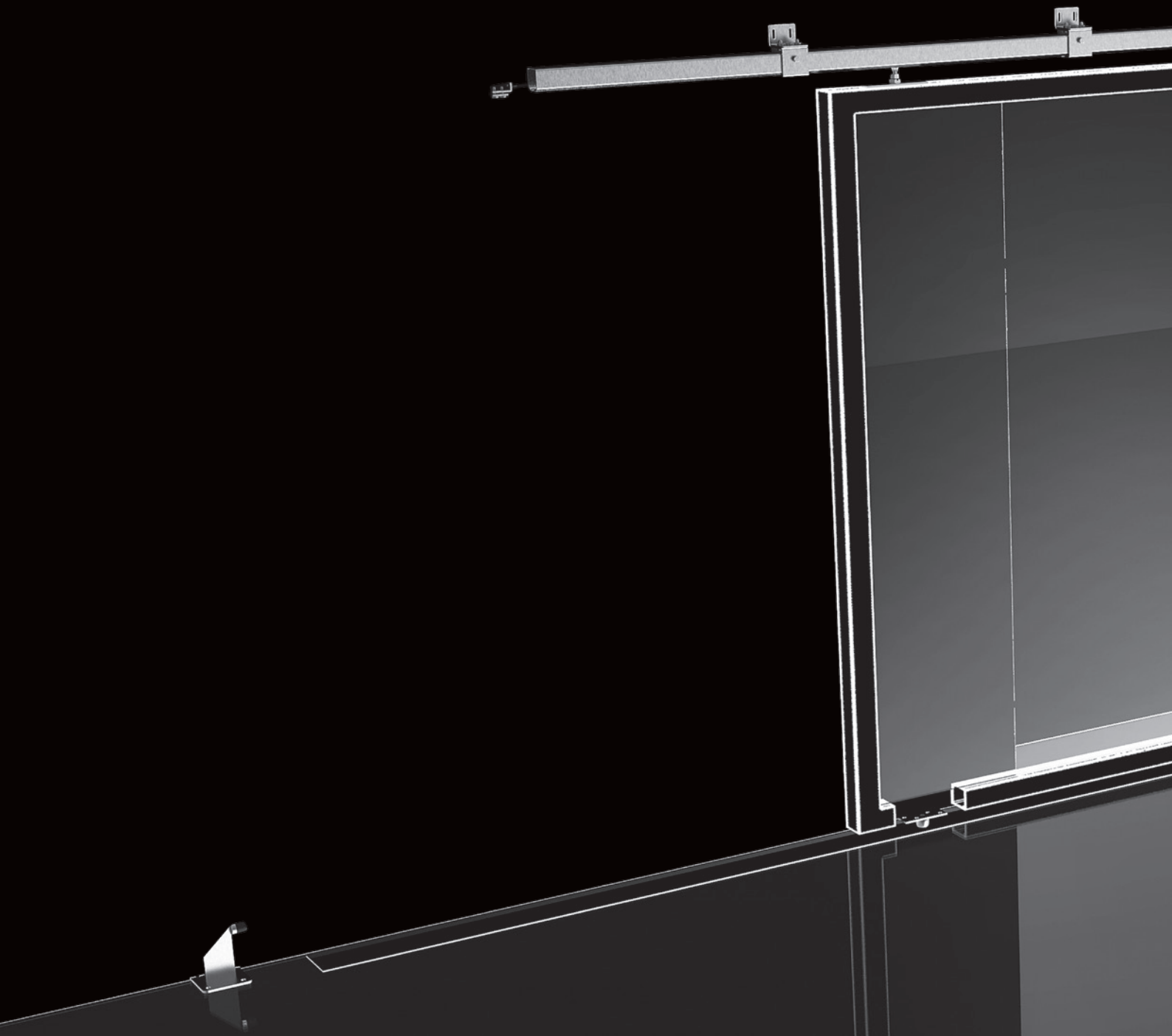

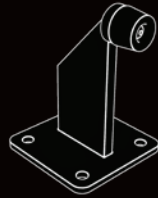
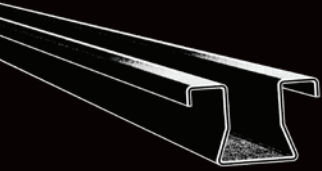
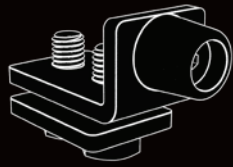
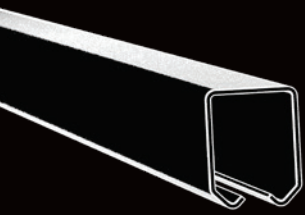

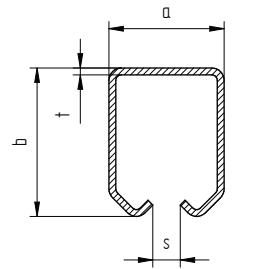
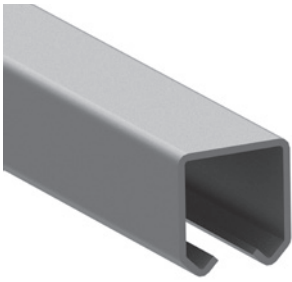

Quality	Finish	art.	a	b	t	s	L				
Fe	raw	H/18-33x34-Fe-3000	33	34	2	10	3000				
		H/18-33x34-Fe-6000					6000				
	Zn	H/18-33x34-Zn-3000					3000				
		H/18-33x34-Zn-6000					6000				
	raw	H/18-42x54-Fe-3000					42	54	2,5	12	3000
		H/18-42x54-Fe-6000									6000
Zn	H/18-42x54-Zn-3000	3000									
	H/18-42x54-Zn-6000	6000									
AISI304	raw	H8/18-42x54-3000	3000								
		H8/18-42x54-6000	6000								
Fe	Zn	H/18-57x67-Zn-3000	57	67	3	16	3000				
		H/18-57x67-Zn-6000					6000				

top

Image	Image	Image
H/18... H8/18...	H/47B... H8/47B...	H/47V... H8/47V...
L3000	5x	
L6000	9x	

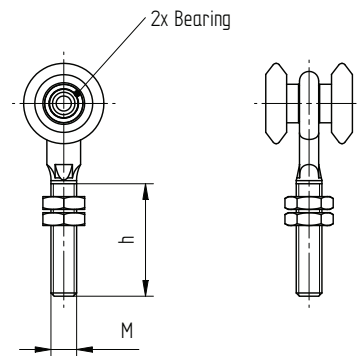

Quality	Finish	art.	M	h	Gmax/2pcs (kg)	Image
Fe	Zn	H/07-33x34	8	35	60	
		H/07-42x54	12	72	200	33x34
		H/07-57x67	20	85	400	42x54

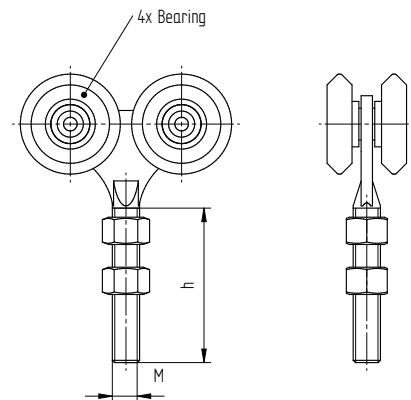

Quality	Finish	art.	M	h	Gmax/2pcs (kg)	Image
Fe	Zn	H/08-33x34	8	35	90	
		H/08-33x34-NYLON			60	
		H/08-42x54			400	
AISI304	raw	H8/08-42x54	12	68	200	42x54
		H/08-57x67	20	85	700	
Fe	Zn	H/08-57x67-NYLON			350	57x67

top

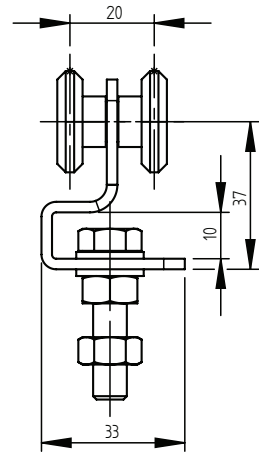
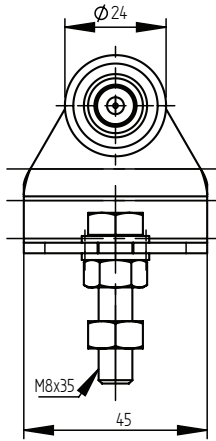

Quality	Finish	art.	Gmax/2pcs (kg)	
Fe	Zn	H/26-33x34	60	33x34

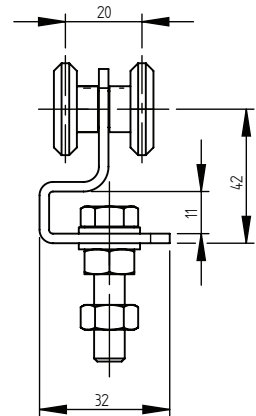
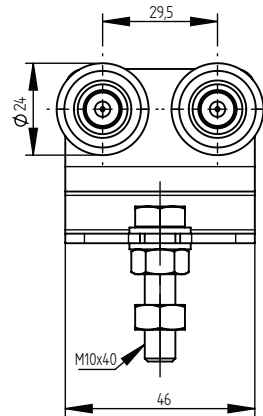

Quality	Finish	art.	Gmax/2pcs (kg)	
Fe	Zn	H/27-33x34	80	33x34
		H/27-33x34-NYLON	40	

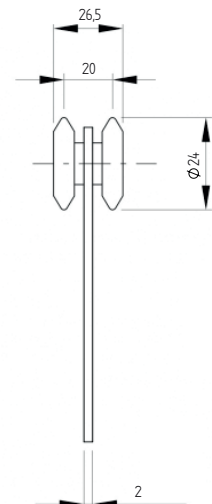
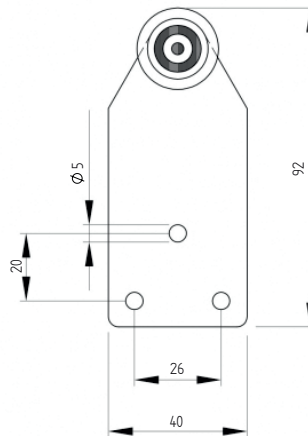

Quality	Finish	art.	Gmax/2pcs (kg)	
Fe	Zn	H/28-33x34	60	33x34

new

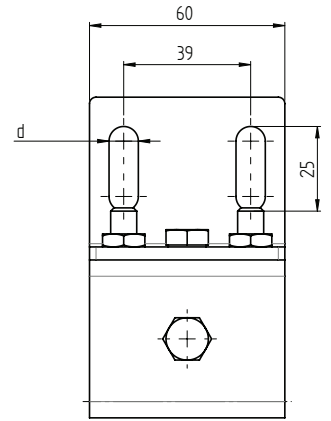
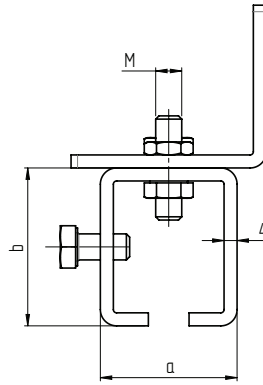

Quality	Finish	art.	a	b	d	k	e	M	
Fe	Zn	H/47B-33x34	42,5	48,5	9	26	35	8	33x34
Fe	Zn	H/47B-42x54	53	72	11	30	37	10	42x54
AISI304	raw	H8/47B-42x54							5x/L3000 9x/L6000
Fe	Zn	H/47B-57x67	66	86			42		57x67

top

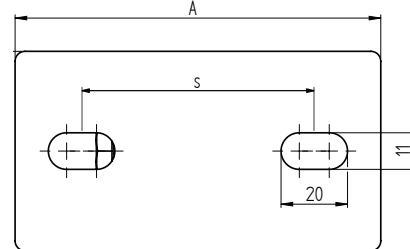
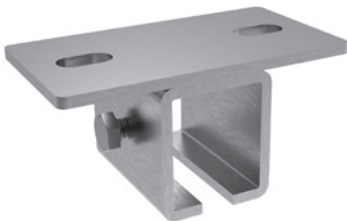
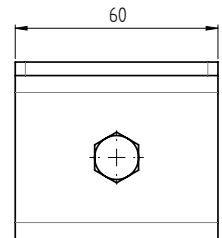
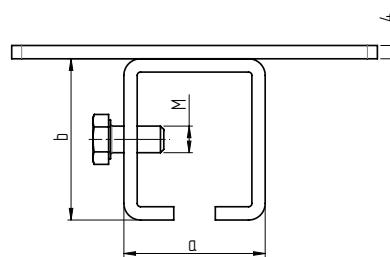
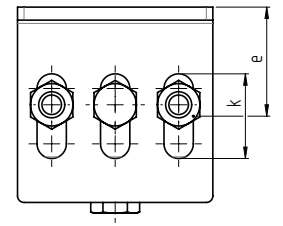

Quality	Finish	art.	A	a	b	s	M	
Fe	Zn	H/47V-33x34	110	42,5	48,5	70	8	33x34
Fe	Zn	H/47V-42x54	120	53	72	80	10	42x54
AISI304	raw	H8/47V-42x54						5x/L3000 9x/L6000
Fe	Zn	H/47V-57x67	130	66	86	94		57x67

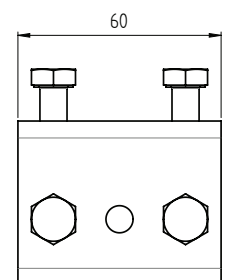
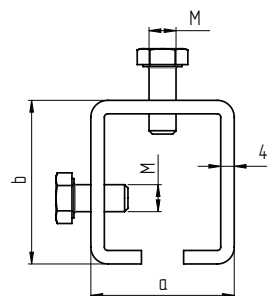
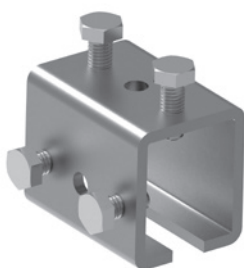

Quality	Finish	art.	a	b	M	
Fe	Zn	H/23-33x34	42,5	48,5	8	33x34
Fe	Zn	H/23-42x54	52,5	72	10	42x54
Fe	Zn	H/23-57x67	66	86		57x67

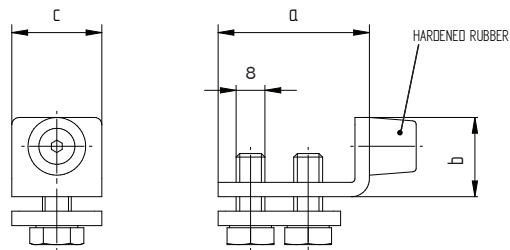

Quality	Finish	art.	a	b	c	
Fe	Zn	H/22	42	22	25	33x34 42x54
		H/22-57x67	59	40	40	57x67

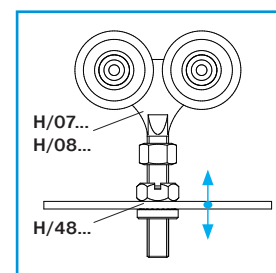
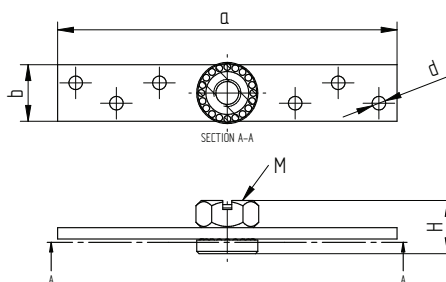

Quality	Finish	art.	M	a	b	d	H	
Fe	Zn	H/48-M8	8	100	20	4x6	20	33x34
		H/48-M12	12	150	25	6x6	24	42x54
		H/48-M20	20	150	40	4x10	32	57x67

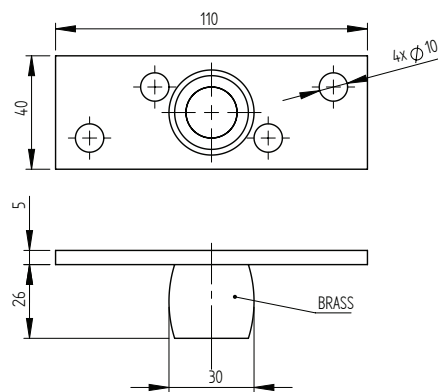

Quality	Finish	art.
Fe + Brass	Zn	H/60

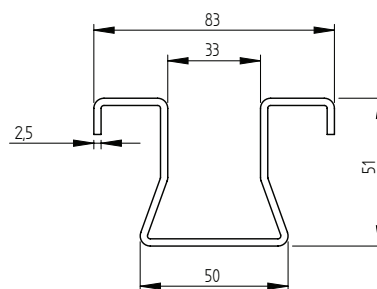

Quality	Finish	art.	L
Fe	Zn	H/59-Zn-3000	3000
		H/59-Zn-6000	6000

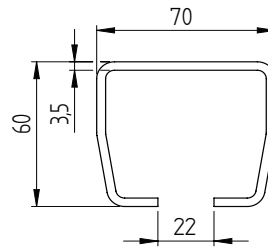
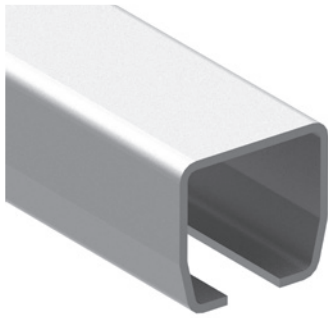

Quality	Finish	art.	L
Fe	raw	H/02-70x60-Fe-3000	3000
		H/02-70x60-Fe-6000	6000
	Zn	H/02-70x60-Zn-3000	3000
		H/02-70x60-Zn-6000	6000



H/08-70x60B



H/08-70x60S

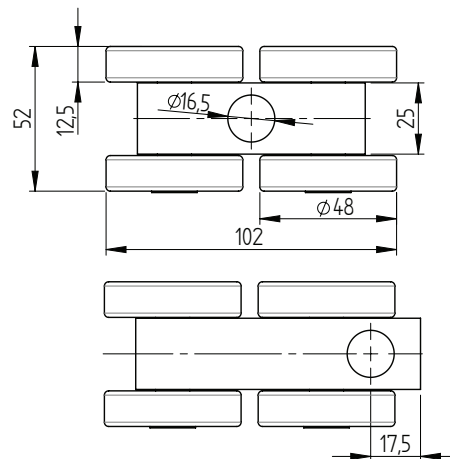

H/48-M16

Quality	Finish	art.	Gmax	
Fe	Zn	H/08-70x60B	400	70x60
		H/08-70x60S		

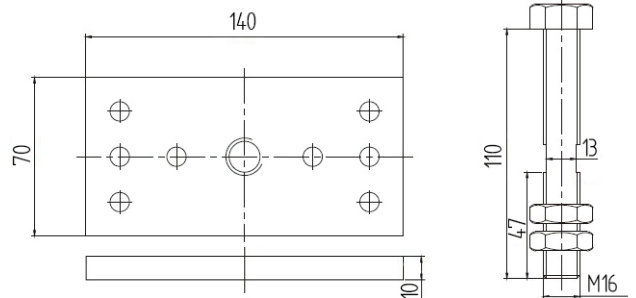

Quality	Finish	art.
Fe	Zn	H/48-M16

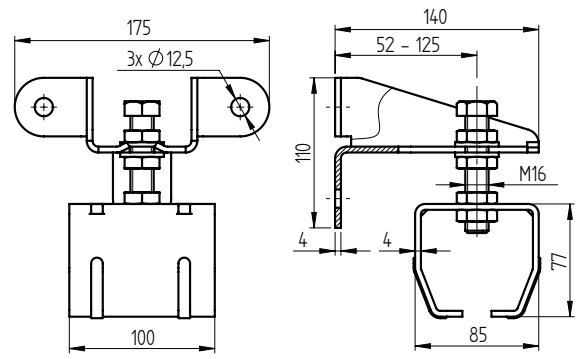
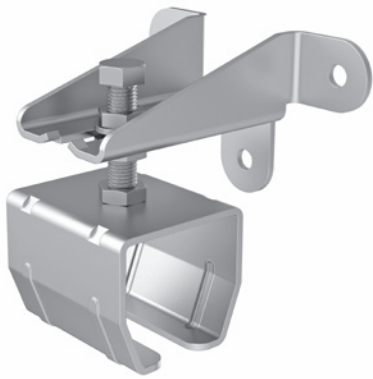

Quality	Finish	art.
Fe	Zn	H/47B-70x60

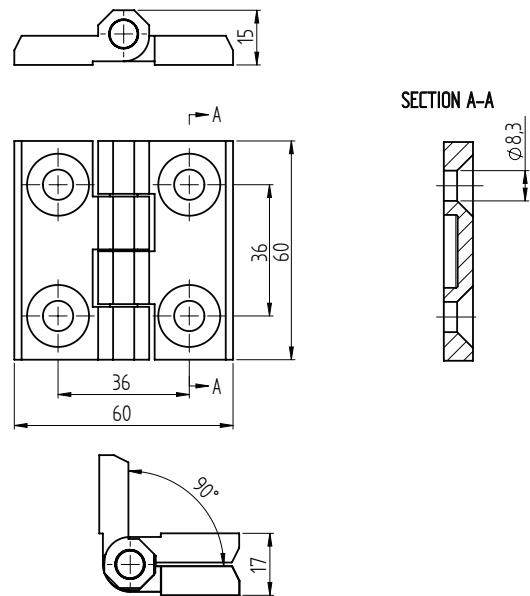
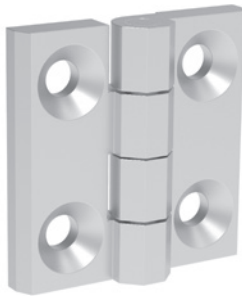

Quality	Finish	art.	Ø	Gmax/2pcs (kg)
AISI316	raw	D16/77-60	Flat	50



5 KRÍDLOVÉ BRÁNY SWING GATES



ZÁVESY FLEX
FLEX HINGES



ZÁVESY FLEX - ATYP
FLEX HINGES - ATYPICAL



ZÁVESY FIX
FIX HINGES



ZÁVESY PRE ALU BRÁNY
HINGES FOR ALU GATES



DORAZY A ZÁSTRČE
BATTENS & LATCHES



ZÁMKOVÉ SETY, KRABICE
LOCK SETS, BOXES



ZÁMKOVE DORAZY
SHRIKING BOXES



ZÁMKY
LOCKS



KOMPATIBILITA
COMPATIBILITY



KLUČKY
HANDLES



ŠTÍTKY
LOCK COVER PLATES

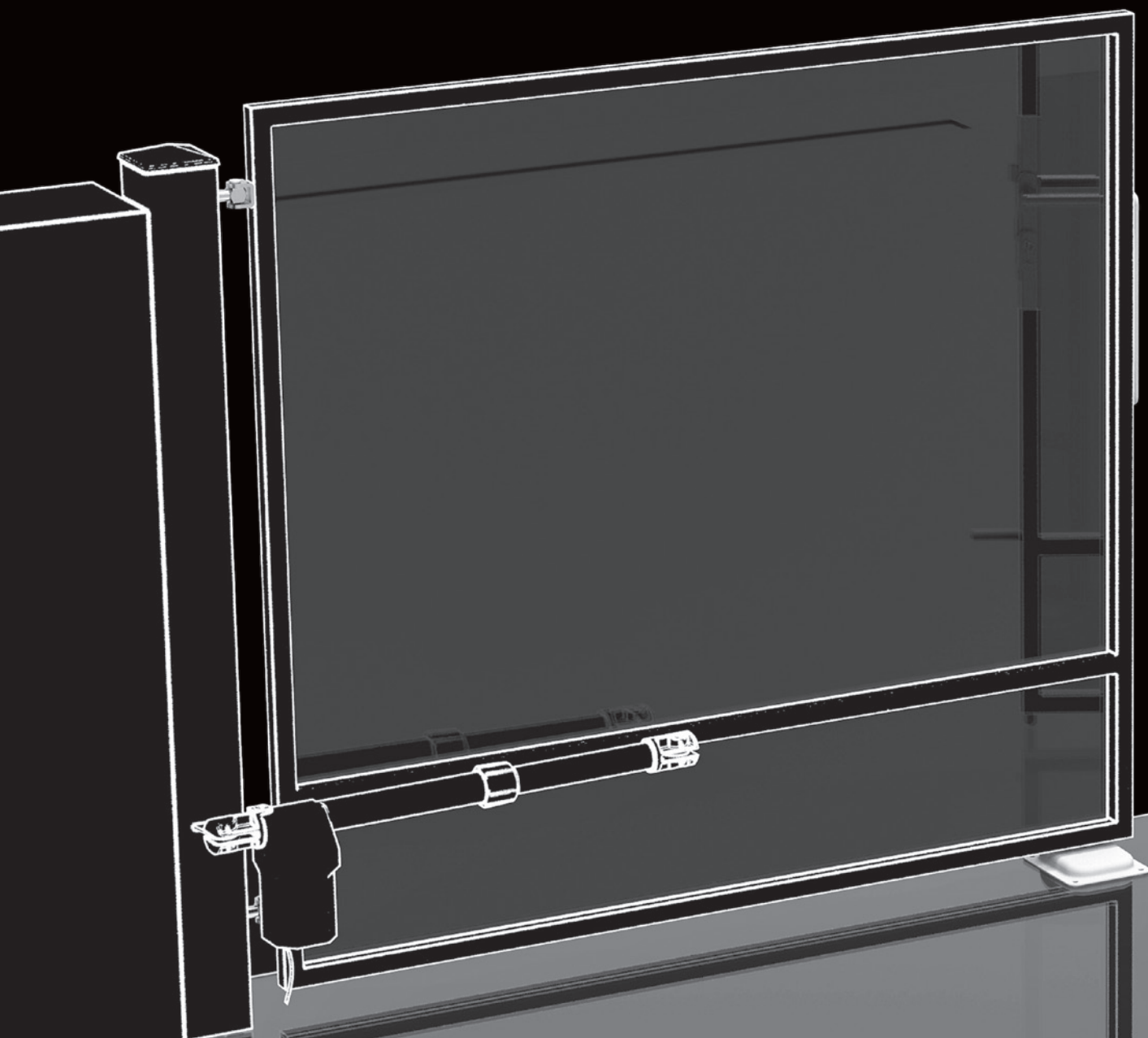

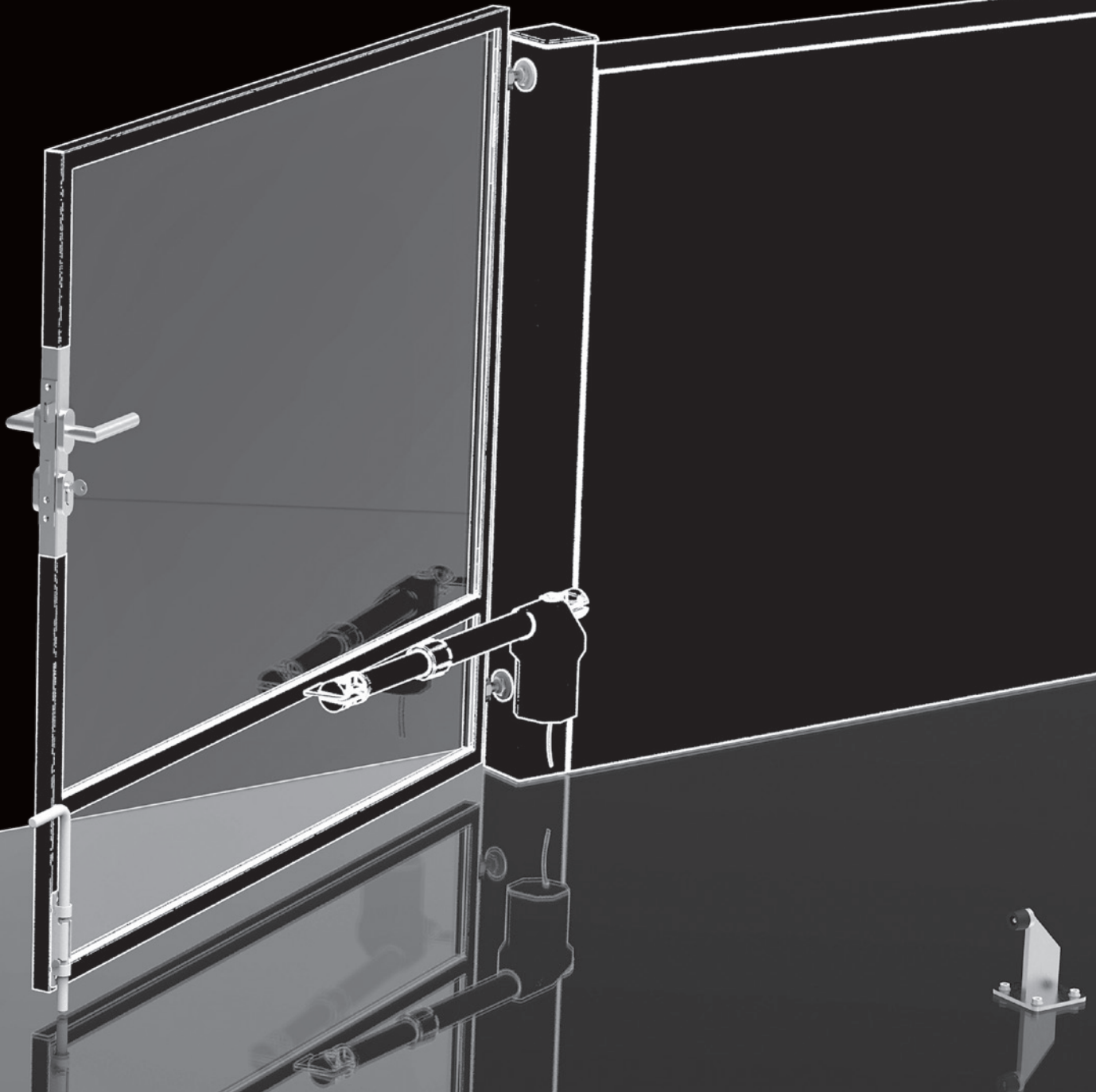
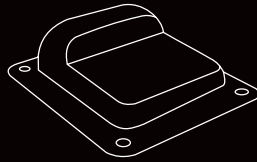

MODEL FLEX - SCREW/WELD

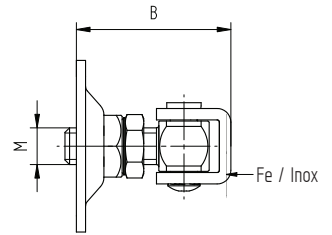
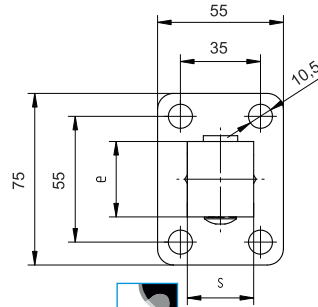
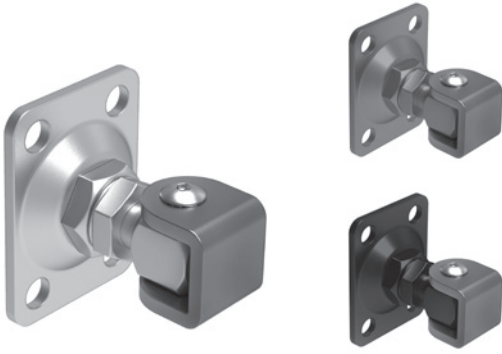

Quality	Finish	art.	Color	M	B	e	s	Gmax/2pcs (kg)
Fe	Zn	D4/53-M12-K	-	12	56-63	27	20	40
AISI304	raw	D8/53-M12-K	-					
		D4/53A-M16-K	-					
Fe	Zn	D4/53A-M16-K-BLACK	black	16	64-75	33	29	60
		D4/53A-M16-K-ANTHR	anthracite					

new
top
new
new



Q5/09-Quick-Fix QF5

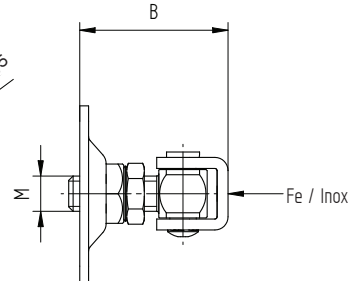
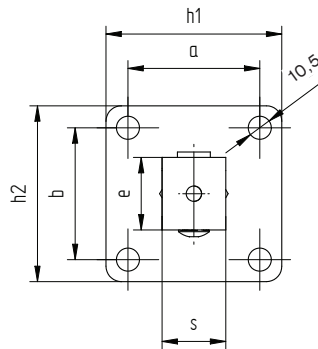
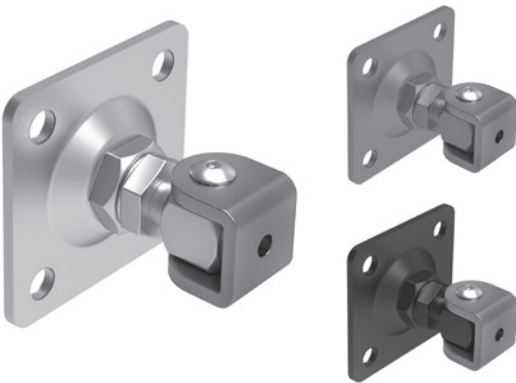

Quality	Finish	art.	Color	M	B	h1xh2	a	b	e	s	Gmax/2pcs (kg)
Fe	Zn	D4/53-M16-K	-								
		D4/53-M16-K-BLACK	black	16	64-75	80x80	55	55	33	29	60
		D4/53-M16-K-ANTHR	anthracite								
AISI304	raw	D8/53-M16-K	-		64-80						
Fe	Zn	D4/53-M18-K	-	18	64-85	90x90	68	68	36	30	80
		D4/53-M20-K	-	20	69-90	100x100	74	74	43		100
AISI304	raw	D8/53-M20-K	-				75	75	35		
Fe	Zn	D4/53-M24-K	-	24	79-115	120x120	90	90	50	35	150

top
new
new



Q5/09-Quick-Fix QF5

MODEL FLEX - SCREW/SCREW

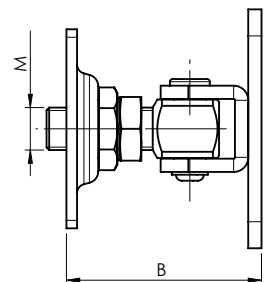
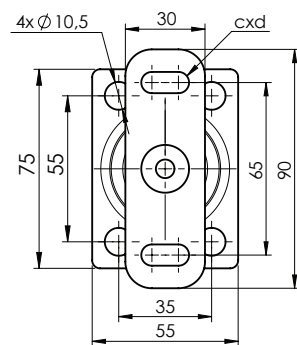
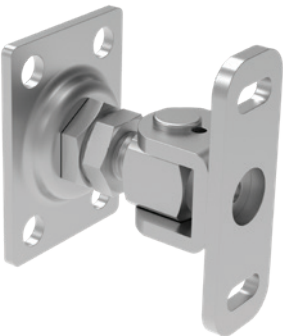

Quality	Finish	art.	M	B	cxd	Gmax/2pcs (kg)
AISI304	raw	D8/53F-M12-K	12	50-70	6x16	40
		D8/53AF-M16-K	16	70-85	8x18	60

new
new



Q5/09-Quick-Fix QF5

MODEL FLEX - SCREW/SCREW

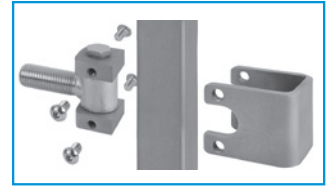
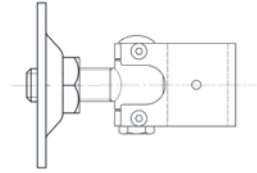
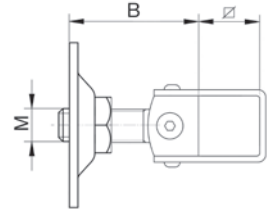
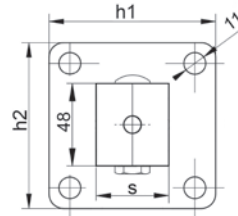
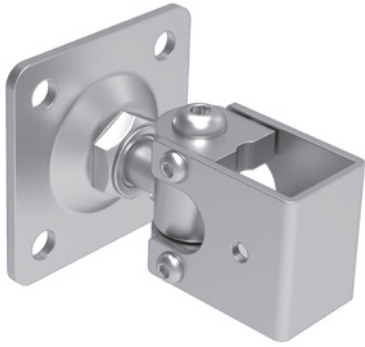

Quality	Finish	art.	Ø	M	B	h1xh2	s	Gmax/2pcs (kg)
Fe	Zn	D4/53-M16-30x30	30x30	16	55-75	80x80	38	200
		D4/53-M16-50x30	50x30					
		D4/53-M20-40x40	40x40	20	65-85	100x100	48	
		D4/53-M20-60x40	60x40					

new
new

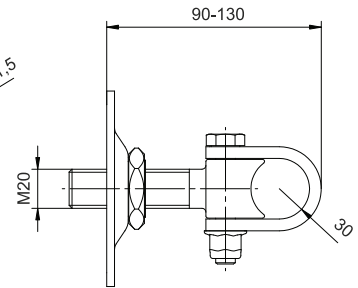
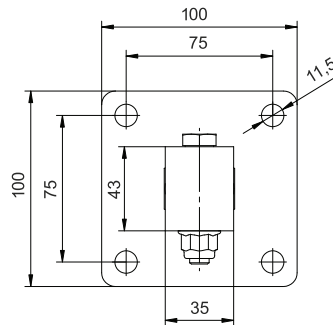
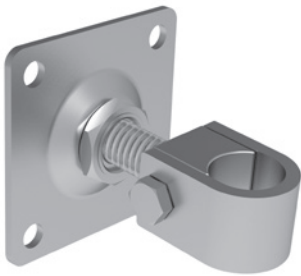

Quality	Finish	art.	Gmax/2pcs (kg)
Fe	Zn	D4/58-M20	100

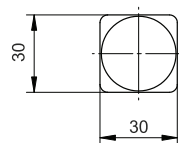
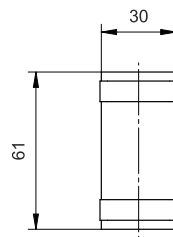

Quality	Finish	art.	Gmax/2pcs (kg)
Fe	Zn	D4/45T-30	100

MODEL FLEX - SCREW

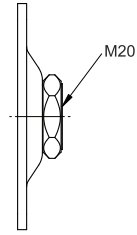
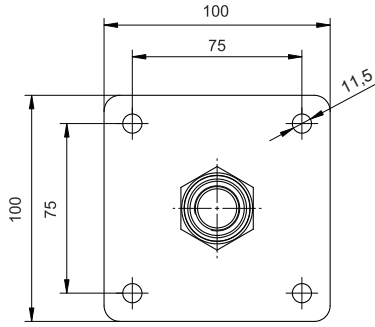

Quality	Finish	art.
Fe	Zn	D4/26A-M20

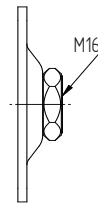
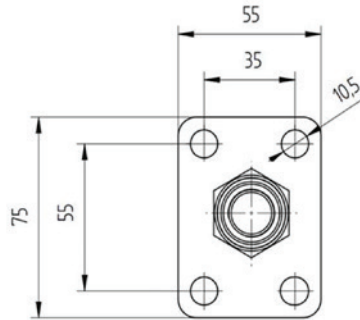

Quality	Finish	art.
Fe	Zn	D4/26B-M16

new

HINGES

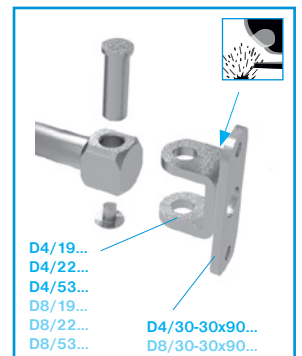
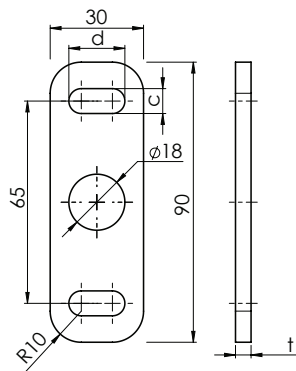

Quality	Finish	art.	c	d	t
Fe	raw	D4/30-30x90x3	6	16	3
AISI304		D8/30-30x90x3			
Fe		D4/30-30x90x5	8	18	5
AISI304		D8/30-30x90x5			

new

MODEL FLEX - WELD/WELD

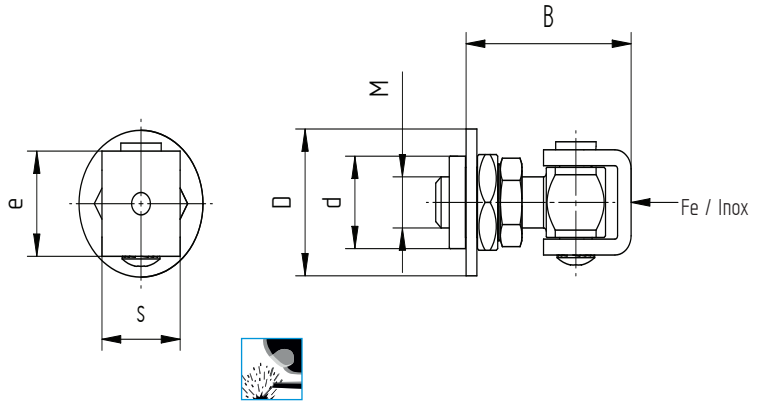

Quality	Finish	art.	M	B	d	D	e	s	Gmax/2pcs (kg)
Fe	Zn	D4/22-M12-K	12	45-53	22	40	27	20	40
AISI304	raw	D8/22-M12-K							
Fe	Zn	D4/22-M16-K	16	54-65	29	46	33	29	60
AISI304	raw	D8/22-M16-K							
Fe	Zn	D4/22-M18-K	18	64-75	35	52	36,5	30	80
AISI304	raw	D8/22-M20-K							
Fe	Zn	D4/22-M20-K	20	59-80	35	52	42	30	100
AISI304	raw	D8/22-M20-K							

new top

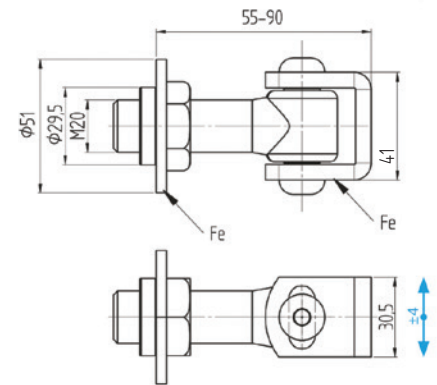

Quality	Finish	art.	Gmax/2pcs (kg)
Fe	Zn	D4/22-M20R	100

MODEL FLEX - WELD/SCREW

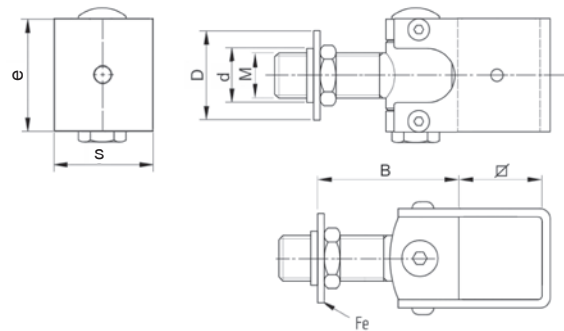
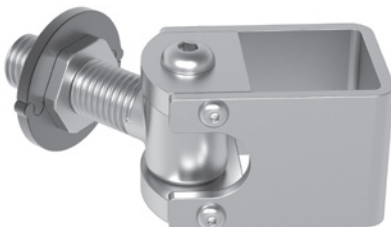

Quality	Finish	art.	∅	M	B	d	D	e	s	Gmax/2pcs (kg)
Fe	Zn	D4/22-M16-30x30	30x30	16	55-75	25	52	46,5	38	200
		D4/22-M16-50x30	50x30							
		D4/22-M20-40x40	40x40	20	65-85	29	60	51,5	48	300
		D4/22-M20-60x40	60x40							

new

new

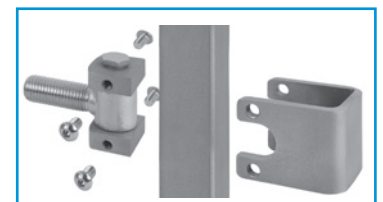

MODEL FLEX - WELD/WELD

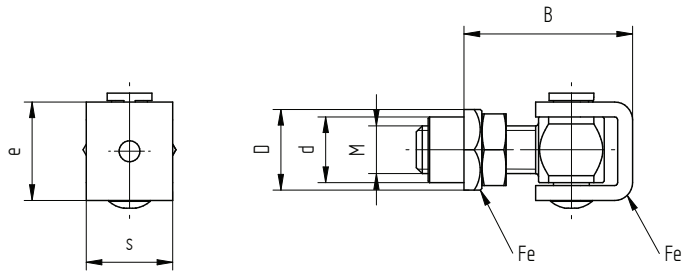

Quality	Finish	art.	M	B	d	D	e	s	Gmax/2pcs (kg)
Fe	Zn	D4/19-M12-K	12	44-55	18	22	26	20	40
		D4/19-M16-K	16	49-60	22	25	33	29	60
		D4/19-M18-K	18	54-70	23	28	36	30	80
		D4/19-M20-K	20	59-70	26	30	43	30	100

top

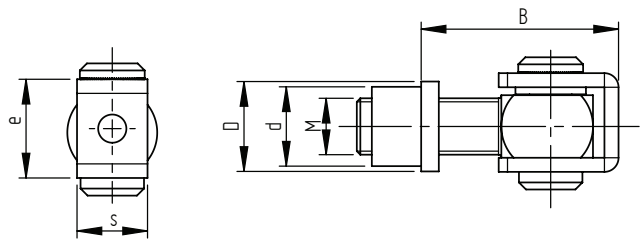

Quality	Finish	art.	M	B	d	D	e	s	Gmax/2pcs (kg)
AISI304	raw	D8/19-M12	12	35-60	18	22	24	16	40
		D8/19-M16	16	40-60	21	29	28	20	60
		D8/19-M20	20	50-70	25	31	37	29	100

HINGES

MODEL FLEX - WELD/SCREW

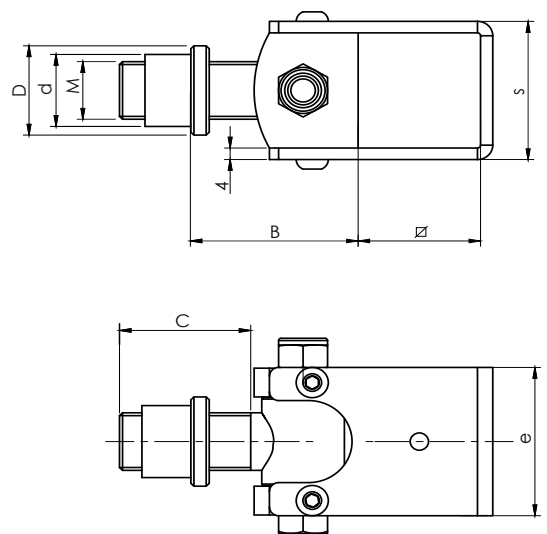
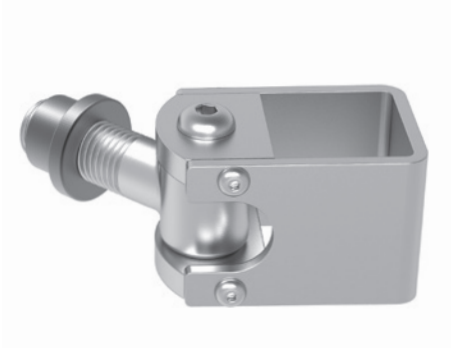

Quality	Finish	art.	M	Ø	B	C	D	d	e	s	Gmax/2pcs (kg)
Fe	Zn	D4/19-M16-30x30	16	30x30	45-60	38	29	22	46,5	38	200
		D4/19-M16-50x30		50x30							
		D4/19-M20-40x40	20	40x40	50-70	43	31	25	51,5	48	300
		D4/19-M20-60x40		60x40							

new
new
new
new

MODEL **FLEX** - WELD/WELD

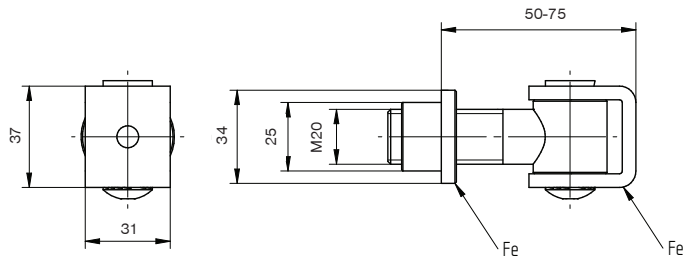

Quality	Finish	art.	Gmax/2pcs (kg)
Fe	Zn	D4/19-M20-N1	100

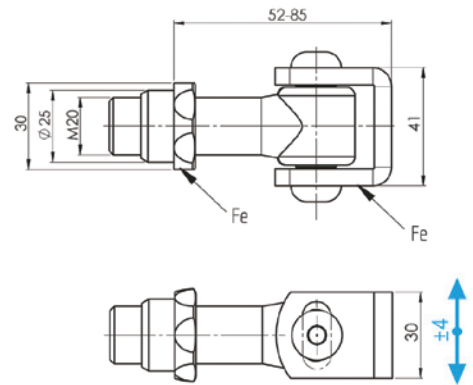

Quality	Finish	art.	Gmax/2pcs (kg)
Fe	Zn	D4/19-M20R	100



MODEL FLEX-ATYP - SCREW/WELD

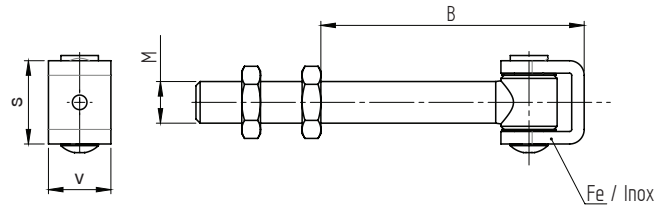

Quality	Finish	art.	M	B	s	v	Gmax/2pcs (kg)
AISI304	raw	D8/67-M12	12	40-125	27	20	40
		D8/67-M16	16	54-167	40	30	60
Fe	Zn	D4/67-M16	16	54-167	40	30	60
		D4/67-M20	20	62-160			100

*new
new*

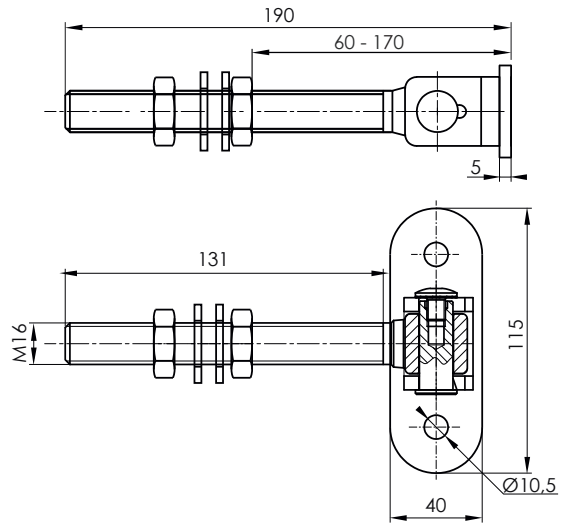

Quality	Finish	art.	M	Gmax/2pcs (kg)
AISI304	raw	D8/67F-M16	16	60

new



HINGES

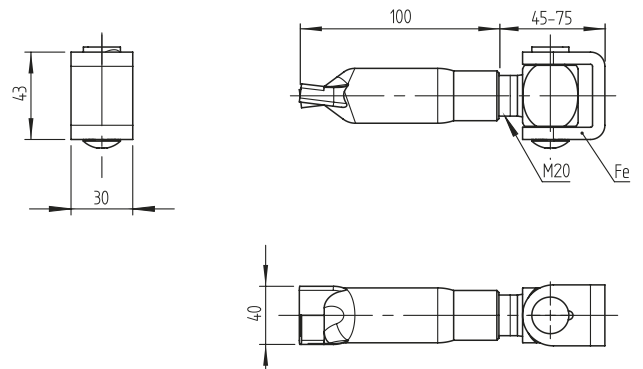

Quality	Finish	art.	Gmax/2pcs (kg)
Fe	Zn	D4/63-M20	100

MODEL FLEX-ATYP - WELD/WELD

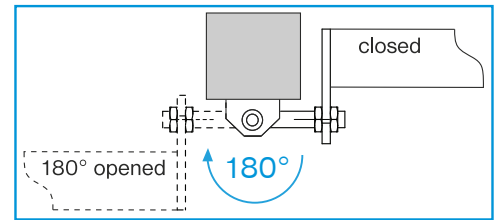
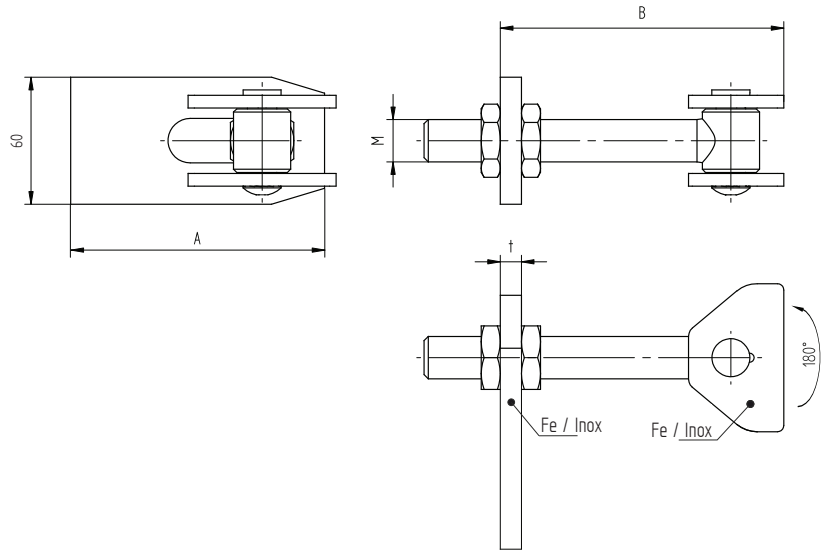
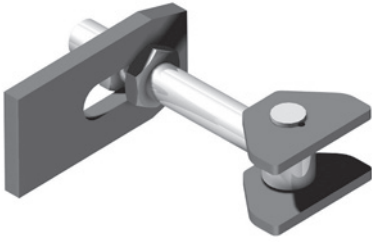

Quality	Finish	art.	M	A	B	t	Gmax/2pcs (kg)
Fe	Zn	D4/64-M16	16	100	60-170	8	60
AISI304	raw	D8/64-M16					
Fe	Zn	D4/64-M20	20	120+	65-160	10	100
AISI304	raw	D8/64-M20					

new

new

MODEL FLEX-ATYP - SCREW/SCREW

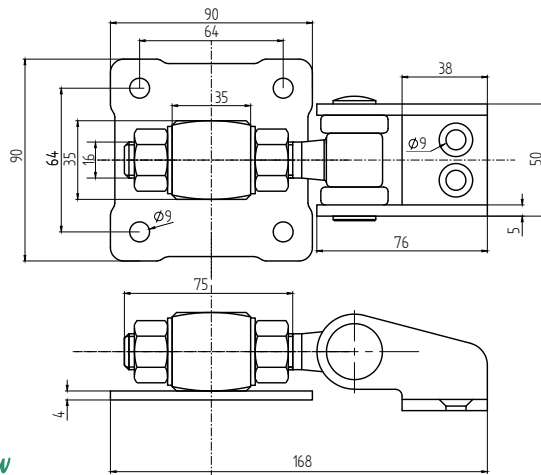
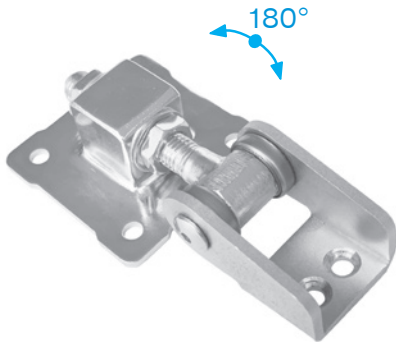

Quality	Finish	art.	Gmax (kg)
Fe	Zn	D4/75-M16	60

new





Quality	Finish	art.	Gmax (kg)
Fe	Zn	D4/52	250

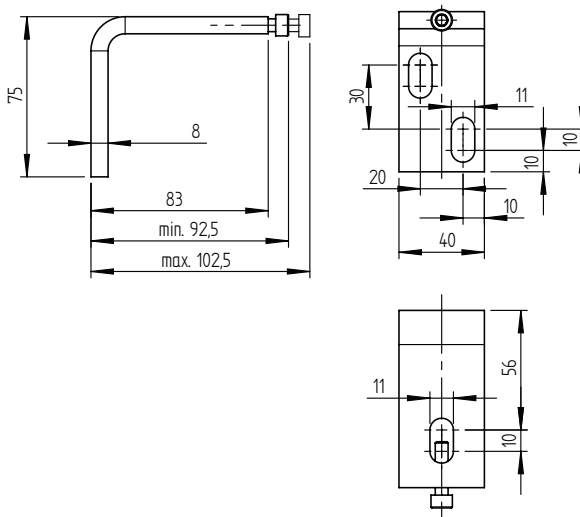
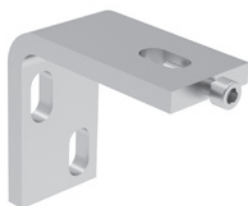
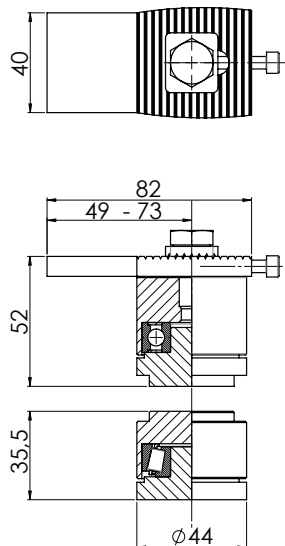

Quality	Finish	art.
Fe	Zn	D4/52-K

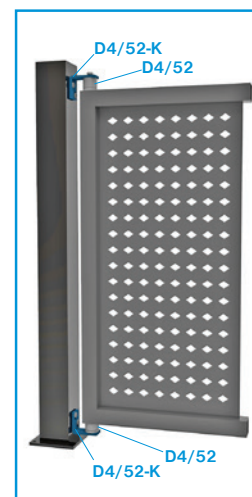

MODEL FLEX-ATYP - HEAVY DUTY



Quality	Finish	art.	Gmax (kg)
Fe	Zn	D4/52-D50	400

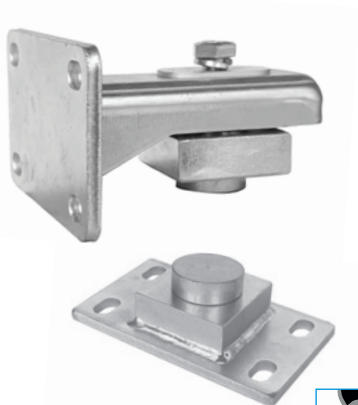
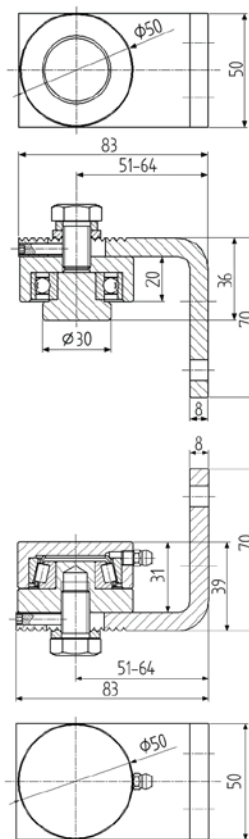

Quality	Finish	art.	Gmax (kg)
Fe	Zn	D4/52P-D40	300

new

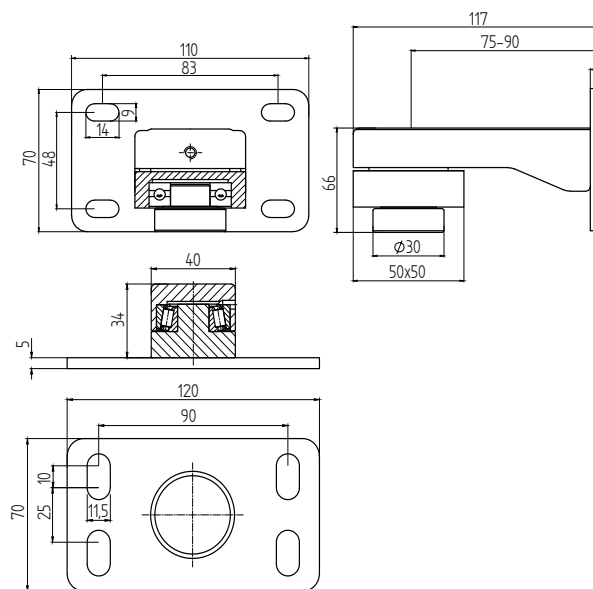

MODEL FLEX-ATYP

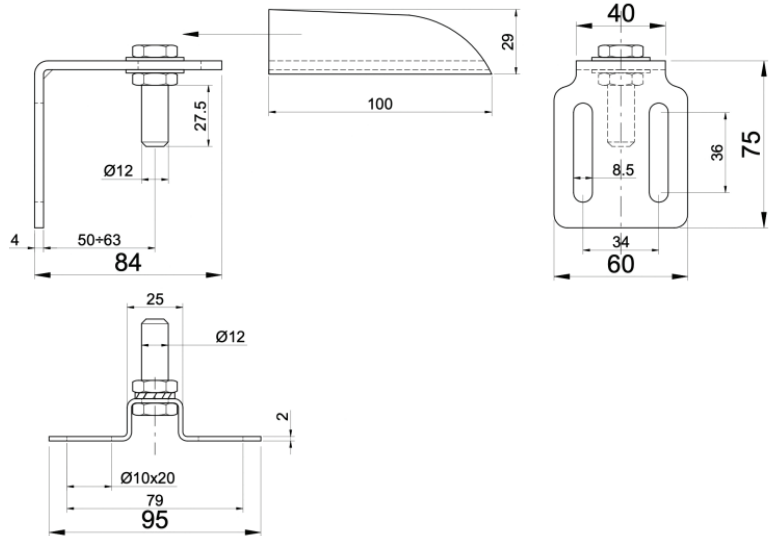

Quality	Finish	Color	art.	Gmax/2pcs (kg)
Fe	raw	grey	D4/83-40x40-GREY	120

new

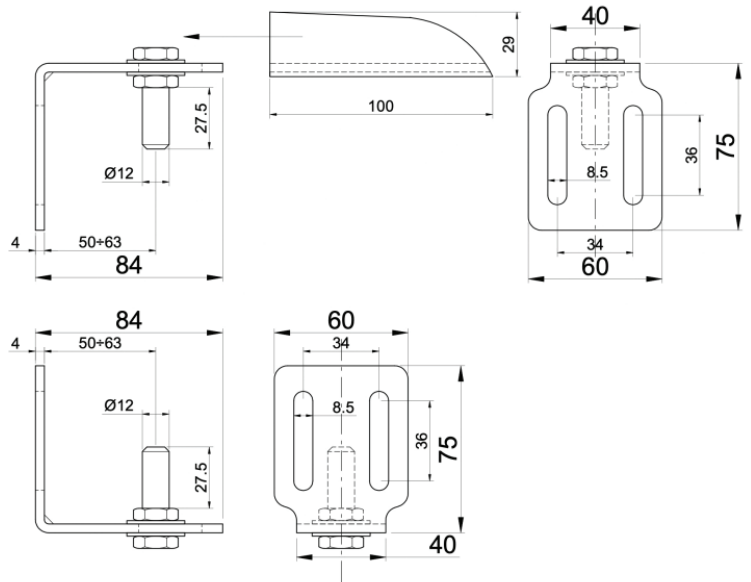

Quality	Finish	Color	art.	Gmax/2pcs (kg)
Fe	raw	grey	D4/84-40x40-GREY	120

new

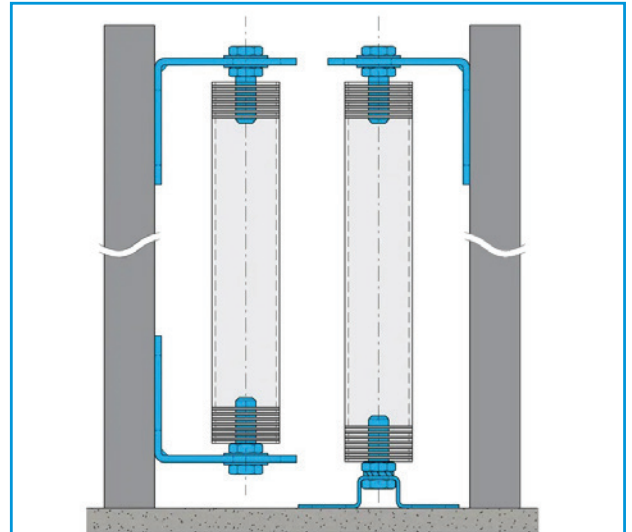

MODEL **FIX-EXCENTRIC**

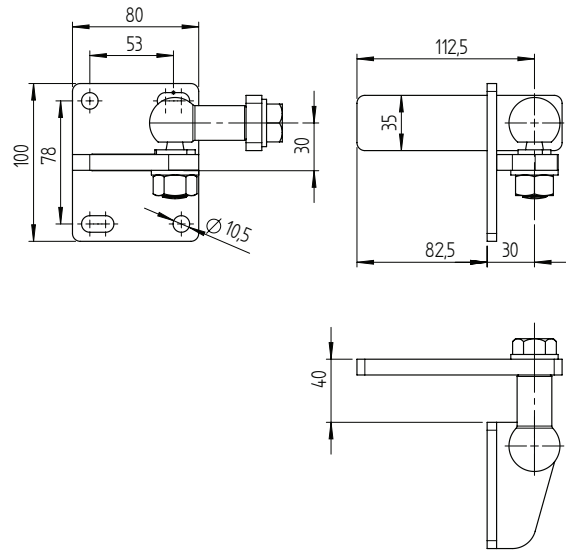

Quality	Finish	art.	Gmax (kg)
Fe	Zn	D4/78V	120

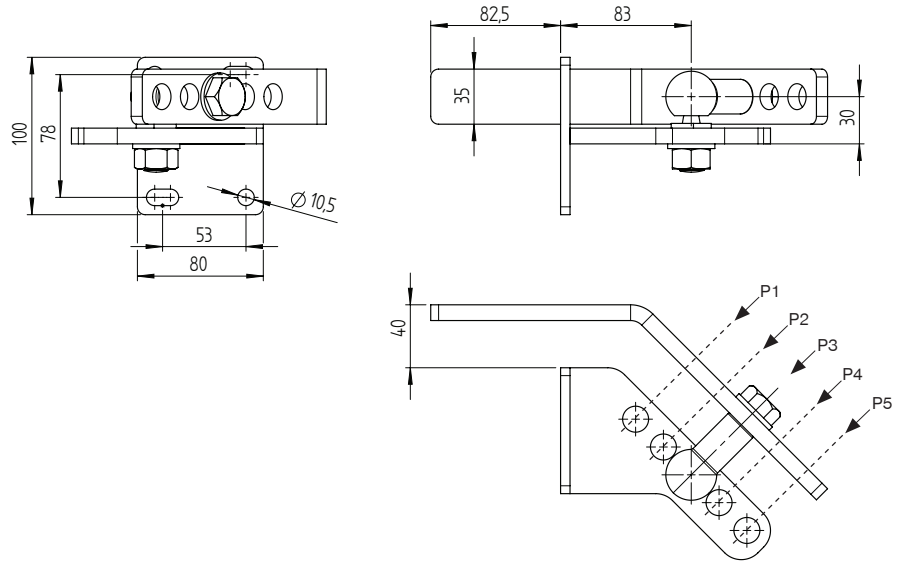
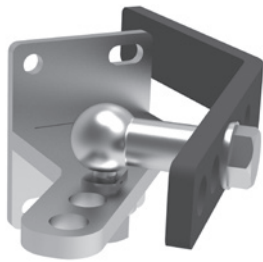

Quality	art.	Finish	Gmax (kg)
Fe	D4/78S	Zn	120

A	B					C pre 2m kridlo				
	Diera 1	Diera 2	Diera 3	Diera 4	Diera 5	Diera 1	Diera 2	Diera 3	Diera 4	Diera 5
800	2,5°	5,1°	7,6°	10,1°	12,6°	88	176	264	351	436
1000	2,0°	4,1°	6,1°	8,1°	10,1°	70	141	211	281	351
1300	1,6°	3,1°	4,7°	6,2°	7,8°	54	109	163	217	271
1600	1,3°	2,5°	3,8°	5,1°	6,3°	44	88	132	176	220
1800	1,1°	2,3°	3,4°	4,5°	5,6°	39	78	118	157	195

MODEL **FIX-WELD**

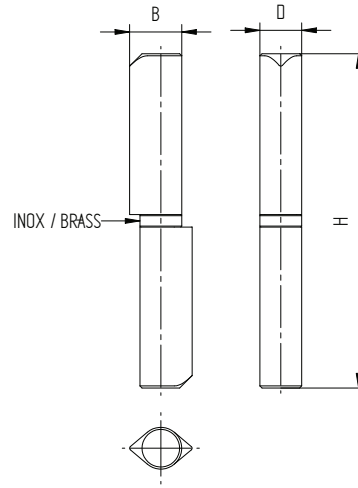

Quality	Finish	art.	D	H	B	Gmax/2pcs (kg)
Fe	raw	D4/11-40	10	40	12	20
AISI304		D4/11-60		60	12	
Fe		D4/11-80	12	80	14	40
AISI304		D4/11-100		100	16	
Fe		D4/11-120	16	120	19	60
AISI304		D8/11-120		20	19	
Fe	D4/11-140	140	19			

top

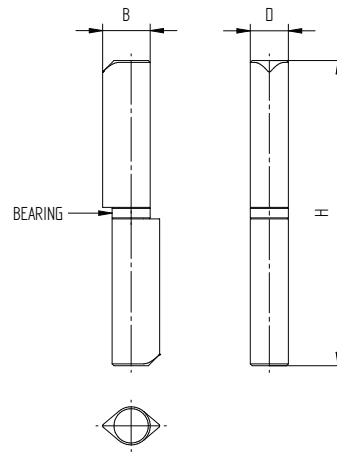

Quality	Finish	art.	D	H	B	Gmax/2pcs (kg)
Fe	raw	D4/11-160	20	160	25	80
		D4/11-180		180	22	
		D4/11-200	22	200	25	100

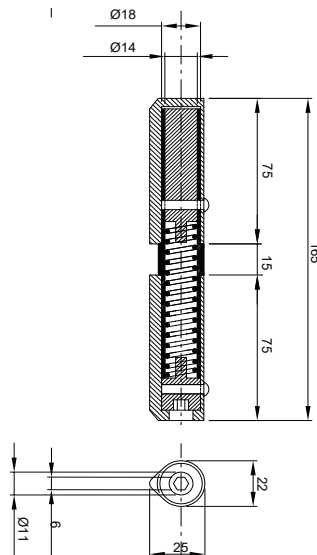

Quality	Finish	art.	Gmax/2pcs (kg)
Fe	raw	D4/11-165S	60
AISI304		D8/11-165S	

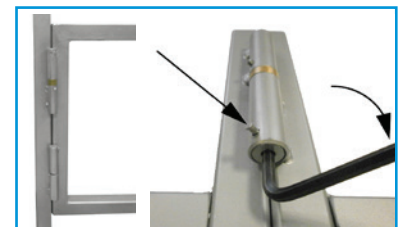

MODEL **FIX-WELD**

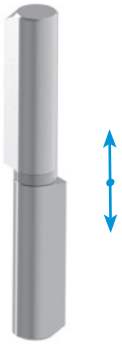

Quality	Finish	art.	Gmax/2pcs (kg)
Fe	raw	D4/11-150R	100

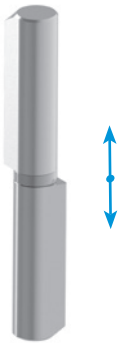
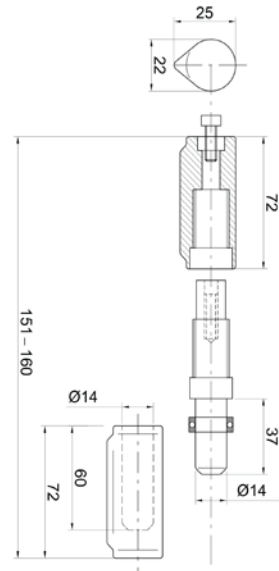

Quality	Finish	art.	Gmax/2pcs (kg)
Fe	raw	D4/11-150RD	100

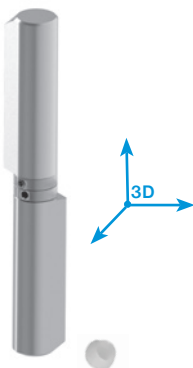
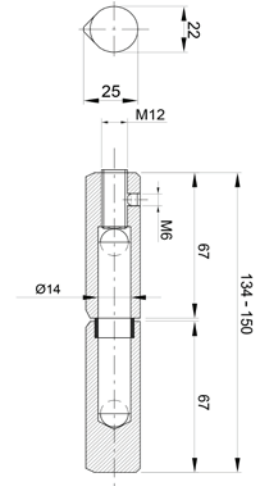

Quality	Finish	art.	Gmax/2pcs (kg)
Fe	raw	D4/11-160-3D	160

new

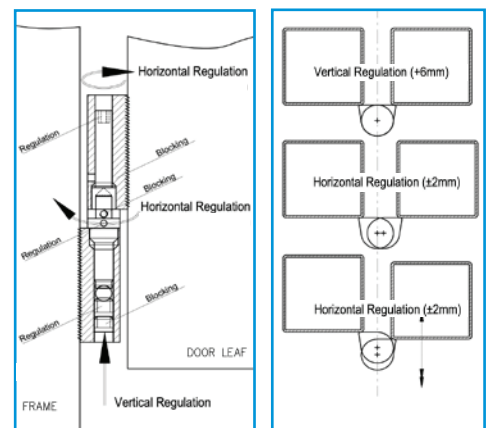
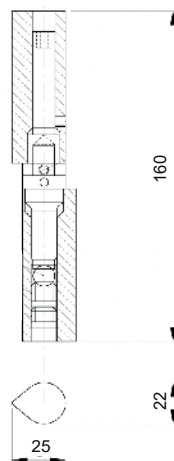

MODEL **FIX-WELD**

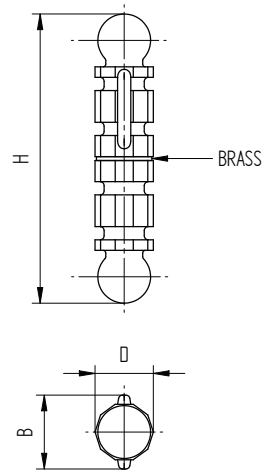
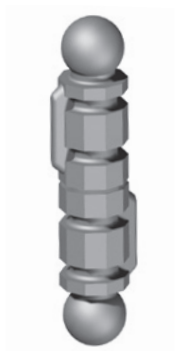

Quality	Finish	art.	D	H	B	Gmax/2pcs (kg)
Fe	raw	D4/41-21	21	110	28	60
		D4/41-25	25	130	35	80
		D4/41-30	30	155	45	100

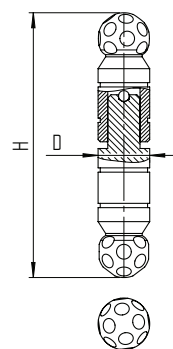

Quality	Finish	art.	D	H	Gmax/2pcs (kg)
Fe	raw	D4/47-100	20	105	60
		D4/47-122	24	125	80
		D4/47-146	30	142	100
		D4/47-195		195	120

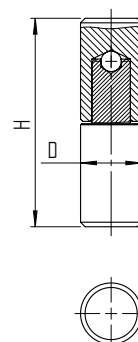

Quality	Finish	art.	D	H	Gmax/2pcs (kg)
Fe	raw	D4/60-70	20	70	80
		D4/60-90	27	90	100

MODEL **FIX-WELD**

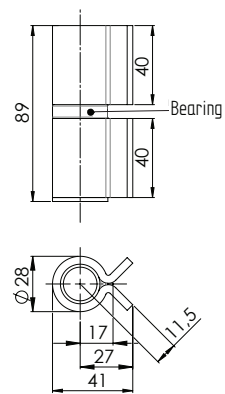

Quality	Finish	art.	Gmax/2pcs (kg)
Fe	raw	D4/13L	80

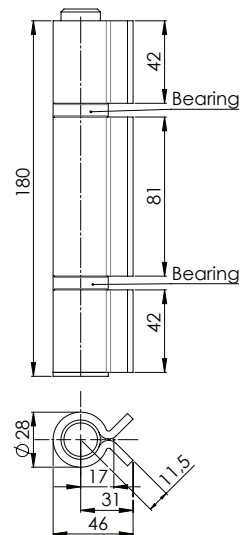
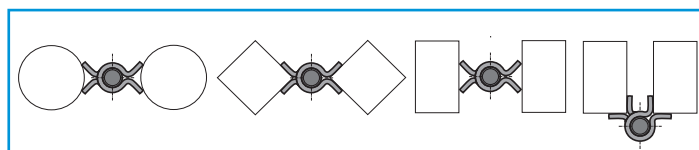

Quality	Finish	art.	Gmax/2pcs (kg)
Fe	raw	D4/14L	120

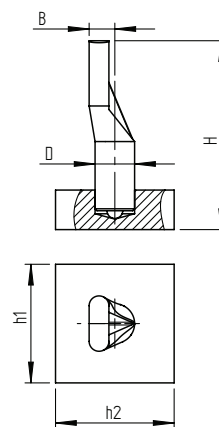

Quality	Finish	art.	B	D	H	h1xh2	Gmax (kg)
Fe	Zn	D4/32-20	19	20	90	60x60	200
		D4/32-24	23	24	100	70x70	300

MODEL FIX-SCREW

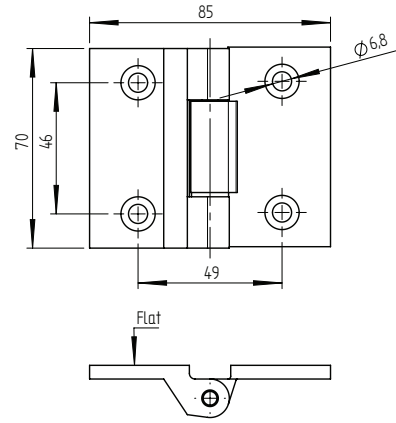

Quality	Finish	art.	Ø	Gmax/2pcs (kg)
AISI316	satın	D16/73-70-000	Flat	50

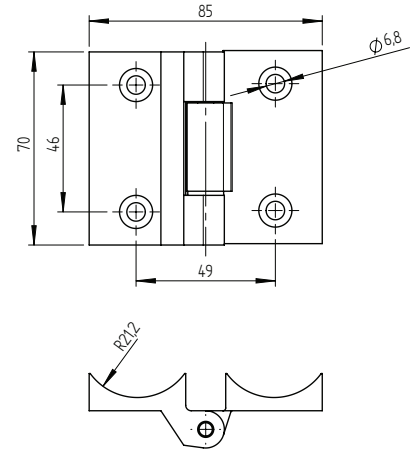

Quality	Finish	art.	Ø	Gmax/2pcs (kg)
AISI316	satın	D16/73-70-042	42,4	50

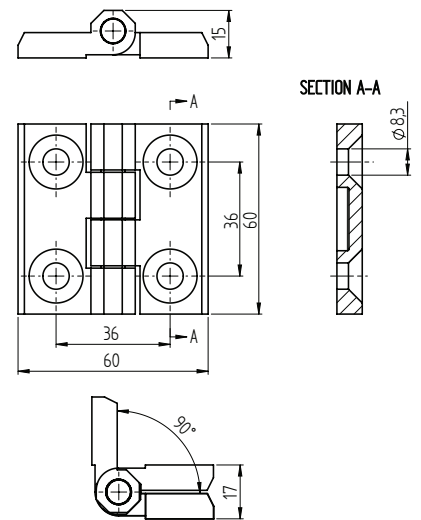
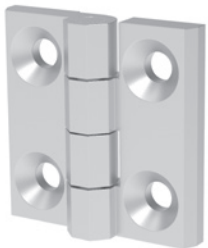

Quality	Finish	art.	Ø	Gmax/2pcs (kg)
AISI316	raw	D16/77-60	Flat	50

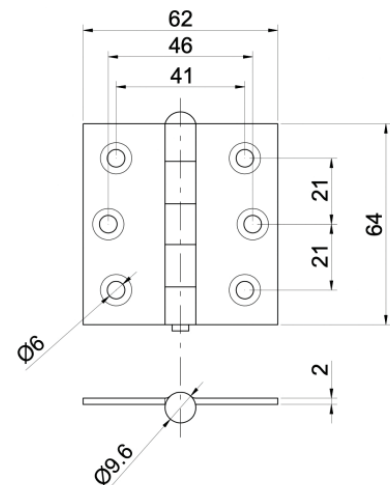

Quality	Finish	art.	Gmax/2pcs (kg)
AISI304	raw	D8/85-64	40

new

MODEL FIX-SCREW

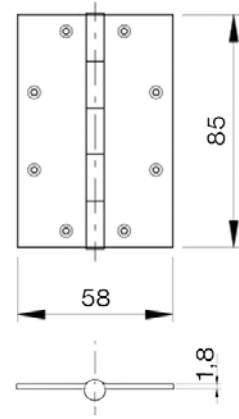

Quality	Finish	art.	Gmax/2pcs (kg)
AISI304	satin	D8/86-85	30

new

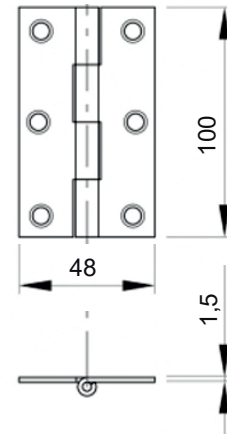

Quality	Finish	art.	Gmax/2pcs (kg)
AISI304	raw	D8/87-100	25

new

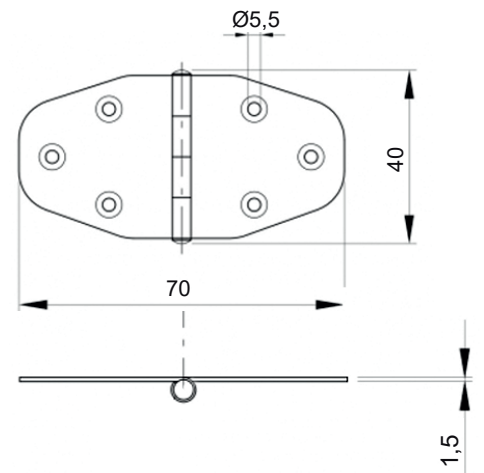

Quality	Finish	art.	Gmax/2pcs (kg)
AISI304	raw	D8/88-40	25

new

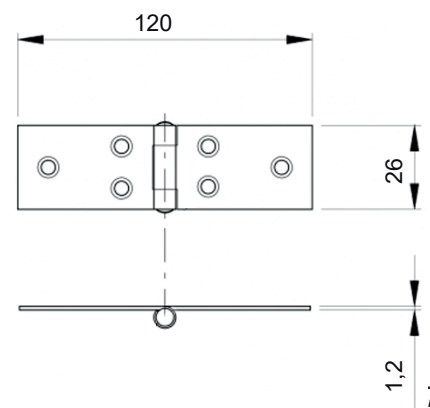

Quality	Finish	art.	Gmax/2pcs (kg)
AISI304	raw	D8/89-26	25

new

MODEL FIX-SPRING

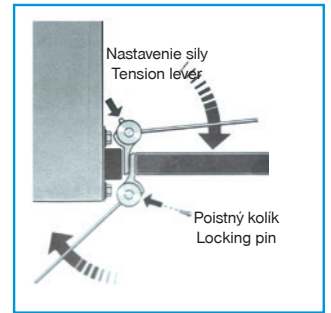
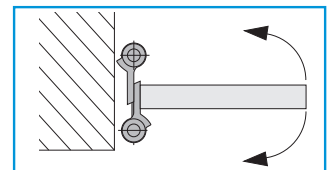
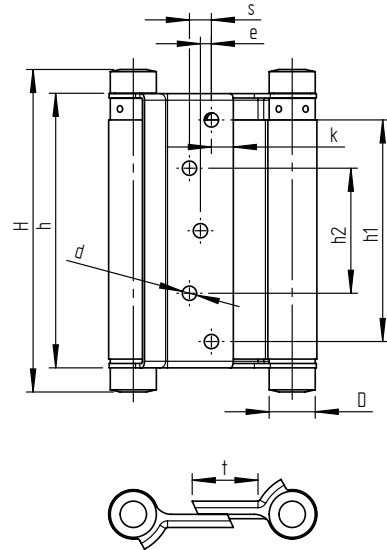

Quality	Finish	art.	H	h	h1	h2	D	d	k	s	e	t	Gmax/2pcs (kg)
AISI304	satin	D8/69-75	92	77	56	32	18	5,5	9	7	-	20	15
		D8/69-100	117	102	77	42	18	5,5	10	7	-	22	22
		D8/69-125	141	126	92	45	20	6,5	11	9	-	28	27
Fe	BRASS	D4/69B-75	98	75	54	21	21	4,5	8,5	6	-	22	15
		D4/69B-100	122	100	78	45	21	5,5	8	9	-	24	22
		D4/69B-125	147	125	101	57	21	5,5	10	11	5	31	27
		D4/69B-150	172	150	126	80	26	5,5	9	14	6	35	40
	Ni	D4/69N-75	97	75	55	24	20	4,5	8	4	-	22	15
		D4/69N-100	124	100	76	43	22	4,5	9	7	-	28	22
		D4/69N-125	148	125	102	57	22	5	9,5	11	6	32	27
		D4/69N-150	172	150	126	80	26	5,5	9,5	14	8	42	40

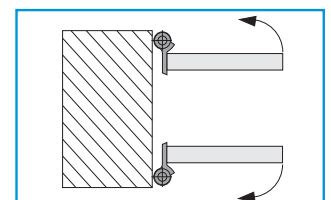
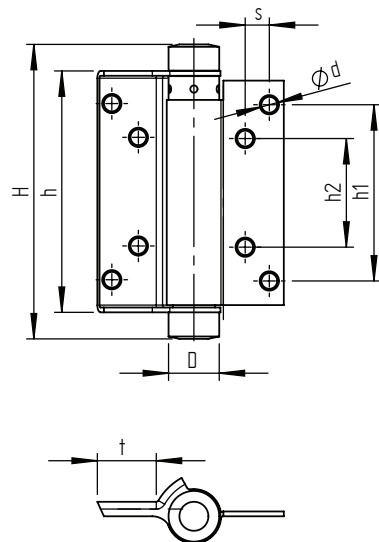
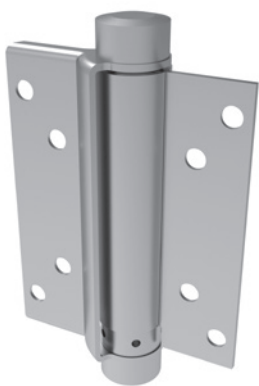

Quality	Finish	art.	H	h	h1	h2	D	d	k	s	t	Gmax/2pcs (kg)
Fe	raw	D4/72Fe-100	122	100	78	45	21	5,5	8,5	9	25	22
	Ni	D4/72N-100										
AISI304	raw	D8/72i-75	93	77	53	26	18	5,5	9	6	25	15
		D8/72i-100	117	102	78	43	18	5,5	7	10,5	22	
		D8/72i-125	141	126	92	45	20	6,5	9	31	27	

HINGES

MODEL FIX-SPRING

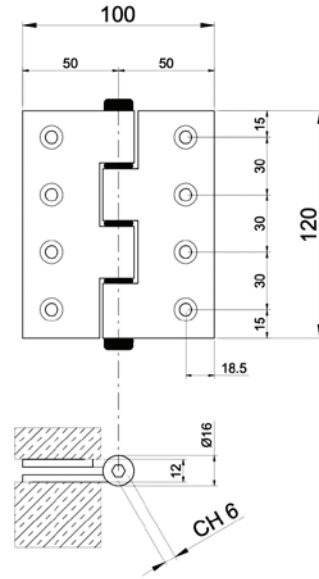

Quality	Finish	Color	art.	Gmax/2pcs (kg)
ALUMINIUM	natural	grey	D4/72AL-120-GREY	20

new

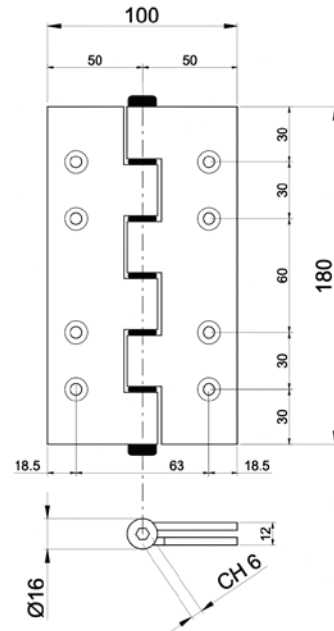

Quality	Finish	Color	art.	Gmax/2pcs (kg)
ALUMINIUM	natural	grey	D4/72AL-180-GREY	30
		white	D4/72AL-180-WHITE	

new
new

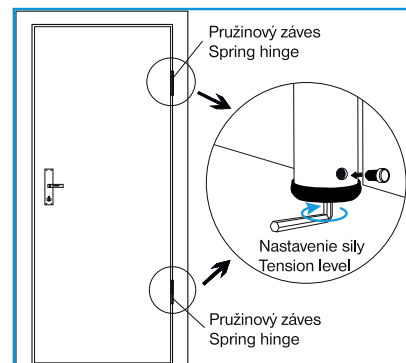

MODEL REINFORCED POLYMER - FOR ALUMINIUM GATES

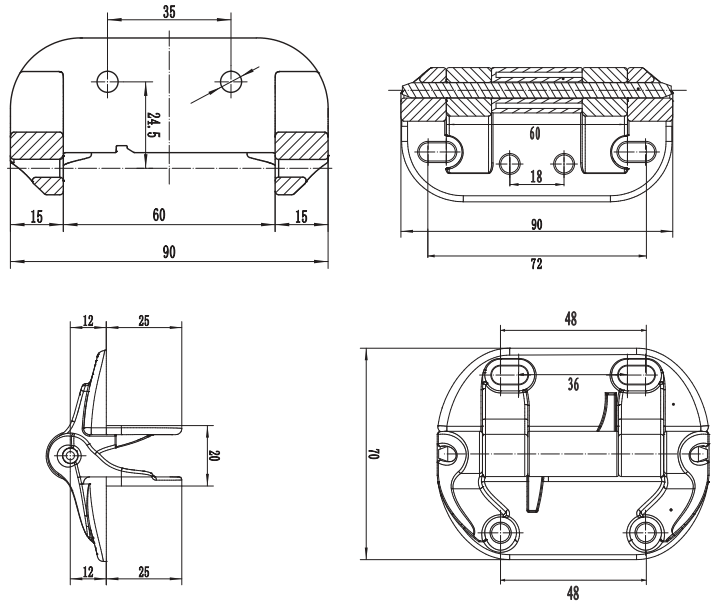

Quality	Finish	art.	Tension	Gmax/2pcs (kg)
fiber-reinforced polymer	raw	D19/01N-90L	neutral	28

new

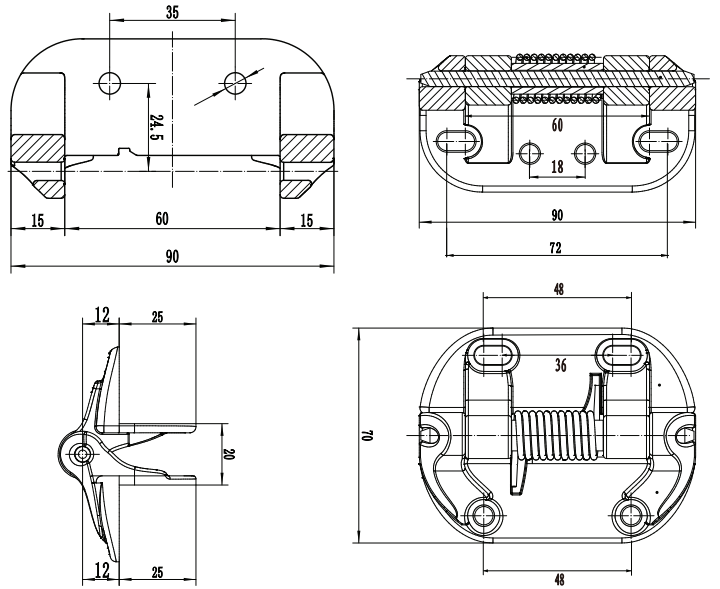

Quality	Finish	art.	Tension	Gmax/2pcs (kg)
fiber-reinforced polymer	raw	D19/01F-90L	fixed	28

new

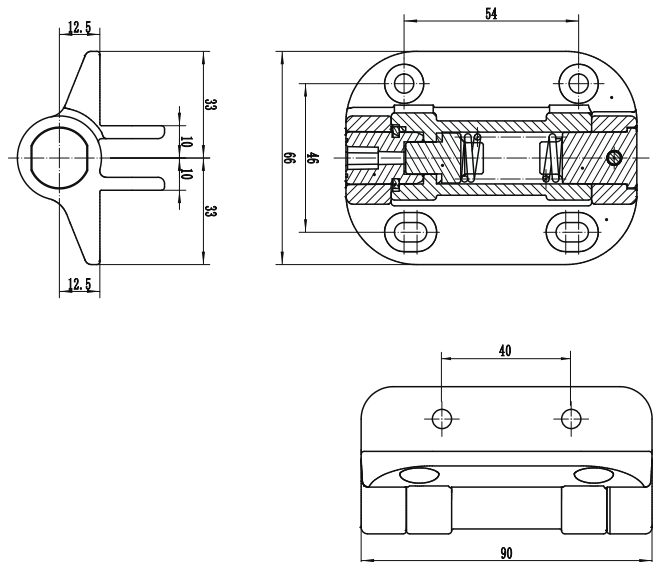

Quality	Finish	art.	Tension	Gmax/2pcs (kg)
fiber-reinforced polymer	raw	D19/04G-90L	adjustable	70

new

HINGES

MODEL REINFORCED POLYMER - FOR ALUMINIUM GATES

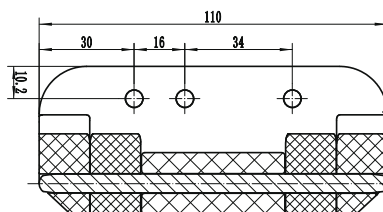
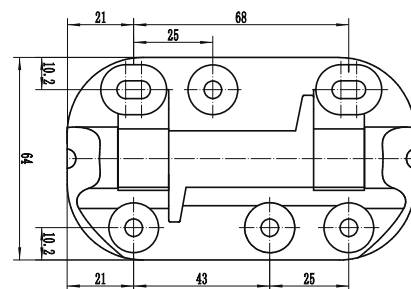
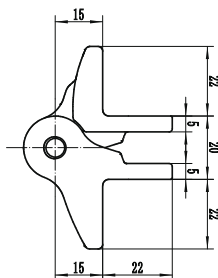

Quality	Finish	art.	Tension	Gmax/2pcs (kg)
fiber-reinforced polymer	raw	D19/02N-110L	neutral	35

new

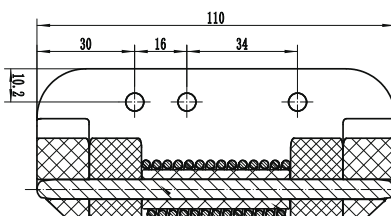
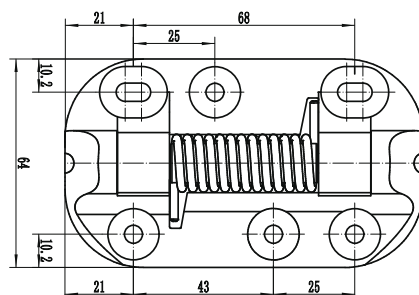
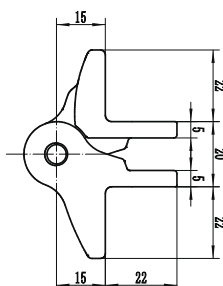

Quality	Finish	art.	Tension	Gmax/2pcs (kg)
fiber-reinforced polymer	raw	D19/02F-110L	fixed	35

new

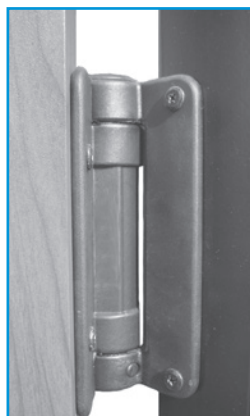

MODEL REINFORCED POLYMER - FOR ALUMINIUM GATES

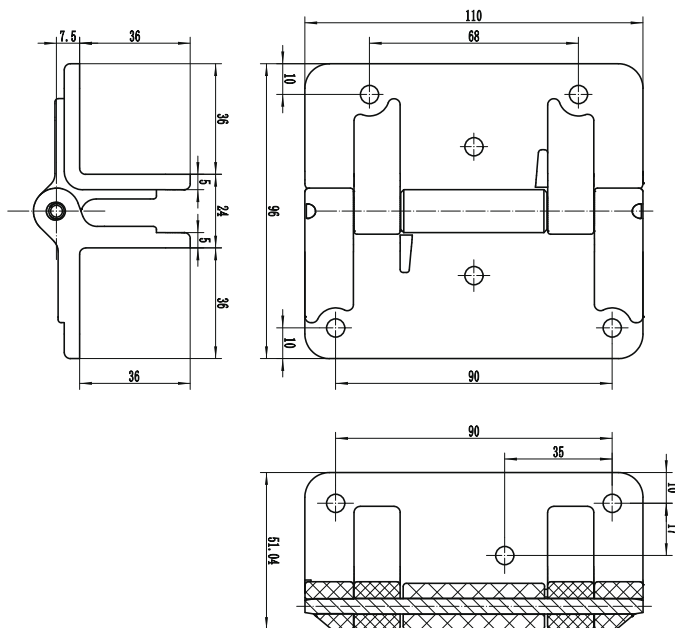

Quality	Finish	art.	Tension	Type	Gmax/2pcs (kg)
fiber-reinforced polymer	raw	D19/03N-110L	neutral	wide leaf	35

new

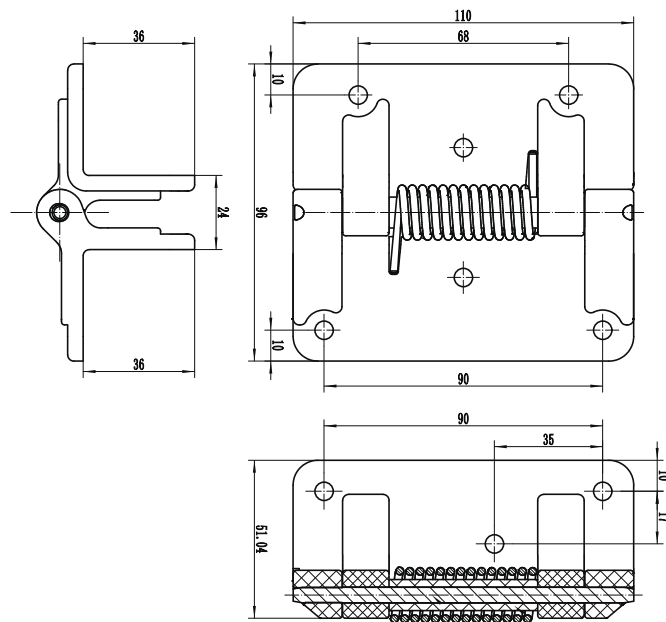

Quality	Finish	art.	Tension	Type	Gmax/2pcs (kg)
fiber-reinforced polymer	raw	D19/03F-110L	fixed	wide leaf	35

new

HINGES



MODEL REINFORCED POLYMER - FOR ALUMINIUM GATES

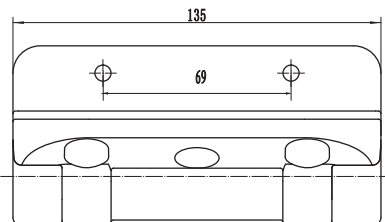
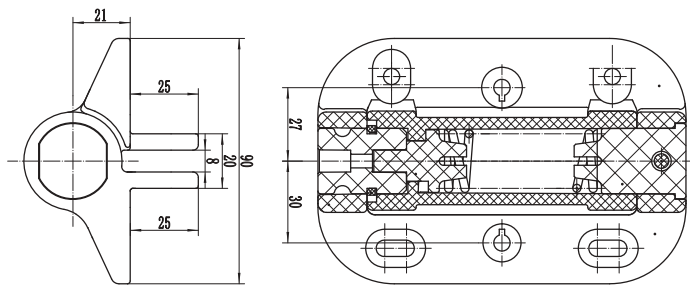

Quality	Finish	art.	Tension	Type	Gmax/2pcs (kg)
fiber-reinforced polymer	raw	D19/05G-135L	adjustable	heavy duty	480

new

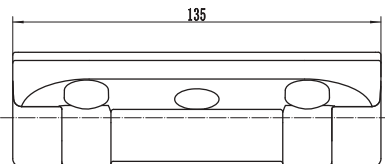
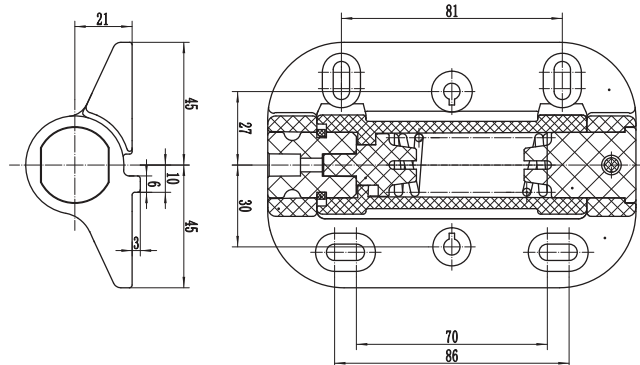

Quality	Finish	art.	Tension	Type	Gmax/2pcs (kg)
fiber-reinforced polymer	raw	D19/05G-135	adjustable	heavy duty (no legs)	480

new

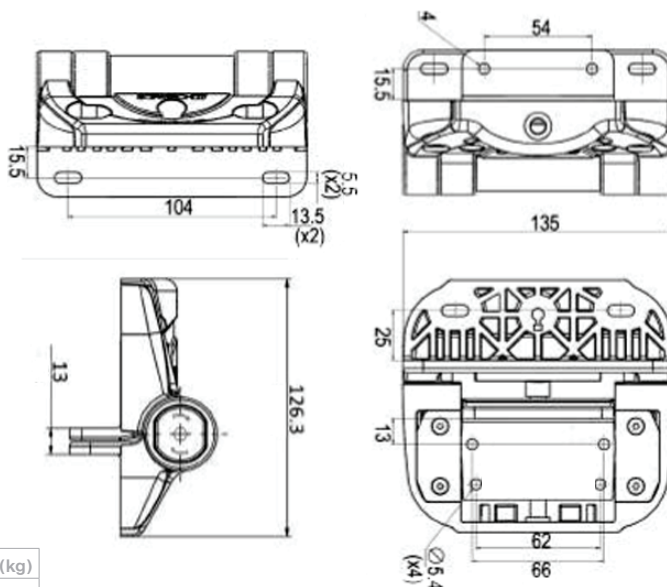

Quality	Finish	art.	Tension	Type	Gmax/2pcs (kg)
fiber-reinforced polymer	raw	D19/06GA-135L	adjustable	heavy duty (fully adjustable)	360

new

MODEL REINFORCED POLYMER - FOR ALUMINIUM GATES

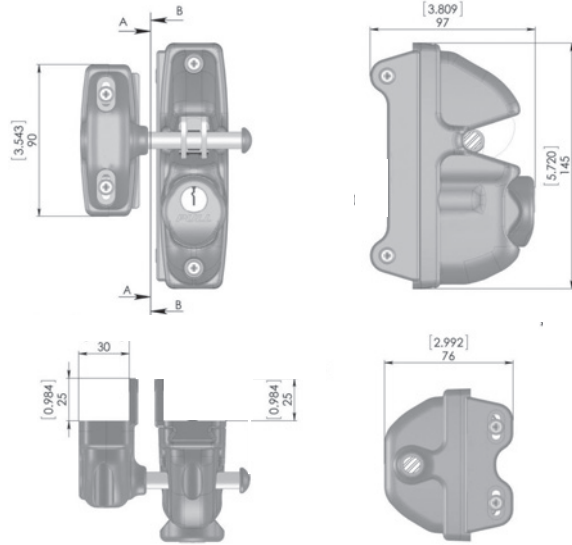

Quality	Finish	art.	type	
fiber-reinforced polymer	raw	B19/01S	hooked (single sided)	✓ <i>new</i>

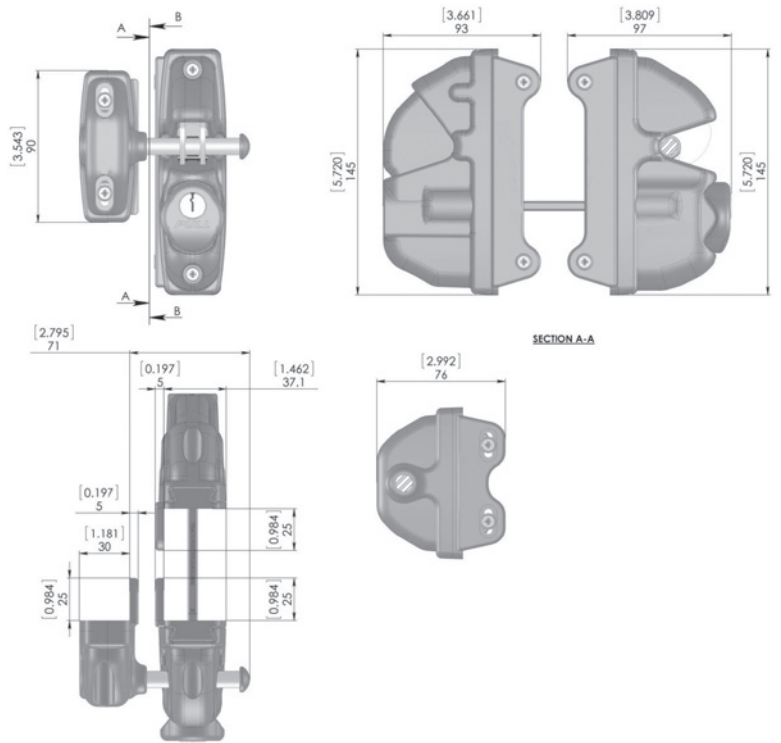

Quality	Finish	art.	type	
fiber-reinforced polymer	raw	B19/01D	hooked (double sided)	✓ <i>new</i>

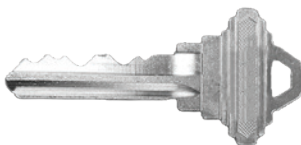

art.	for
B19/01-KEY	B19/01S B19/01D <i>new</i>

MODEL REINFORCED POLYMER - FOR ALUMINIUM GATES



Quality	Finish	art.	type
fiber-reinforced polymer	raw	B19/02S	magnetic (side pull) <i>new</i>

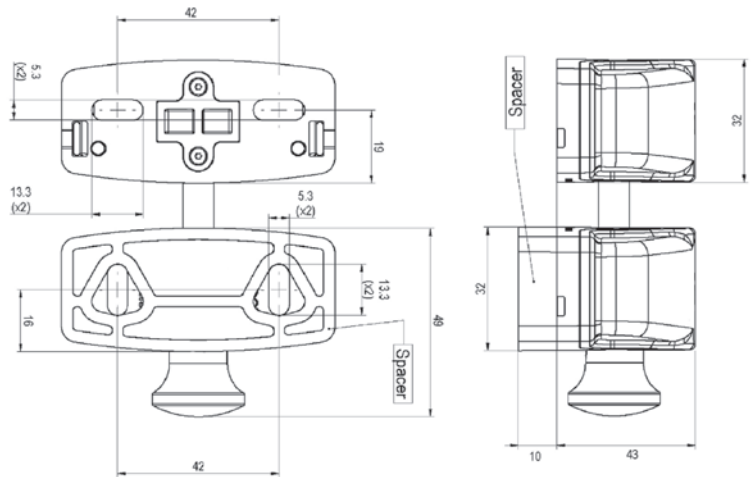

Quality	Finish	art.
fiber-reinforced polymer	raw	B19/06-150 <i>new</i>

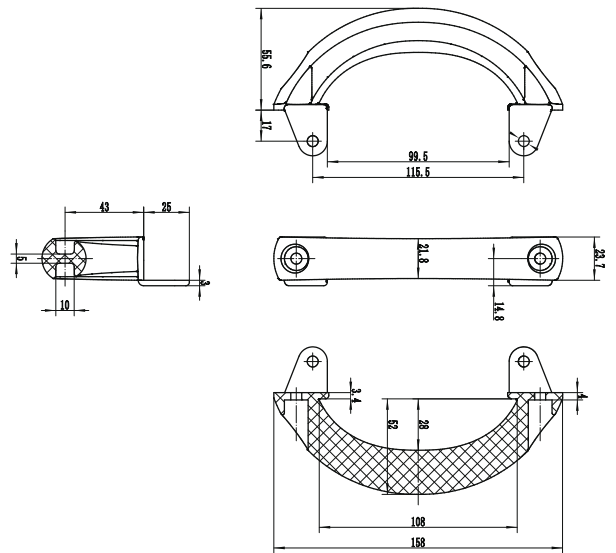

Quality	Finish	art.
fiber-reinforced polymer	raw	B19/05S-45 <i>new</i>

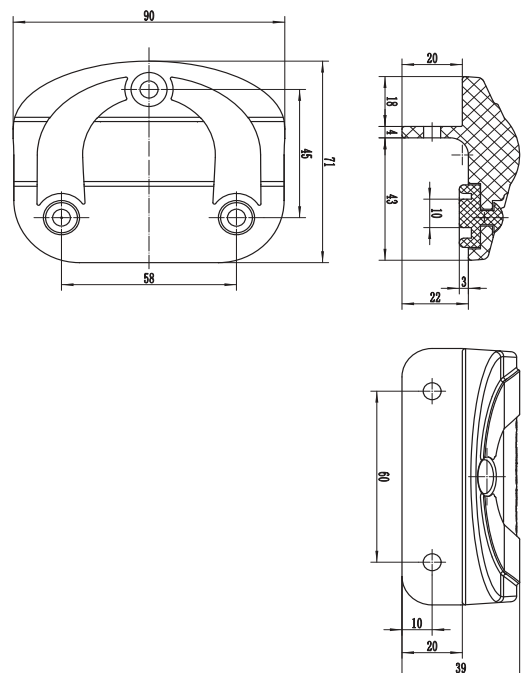

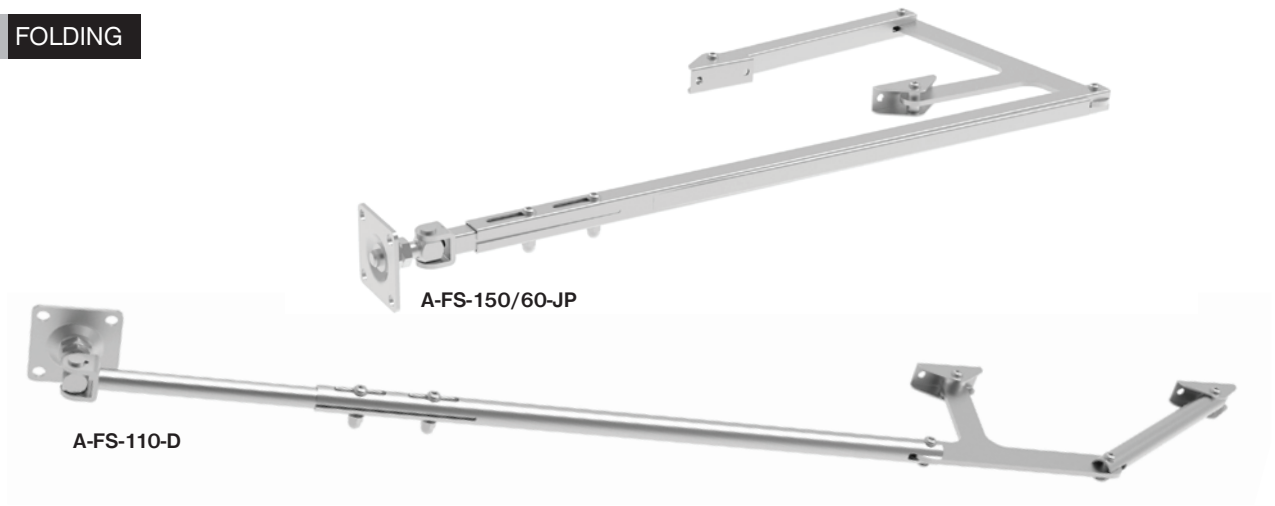

A-FS-150/60-JP

A-FS-110-D

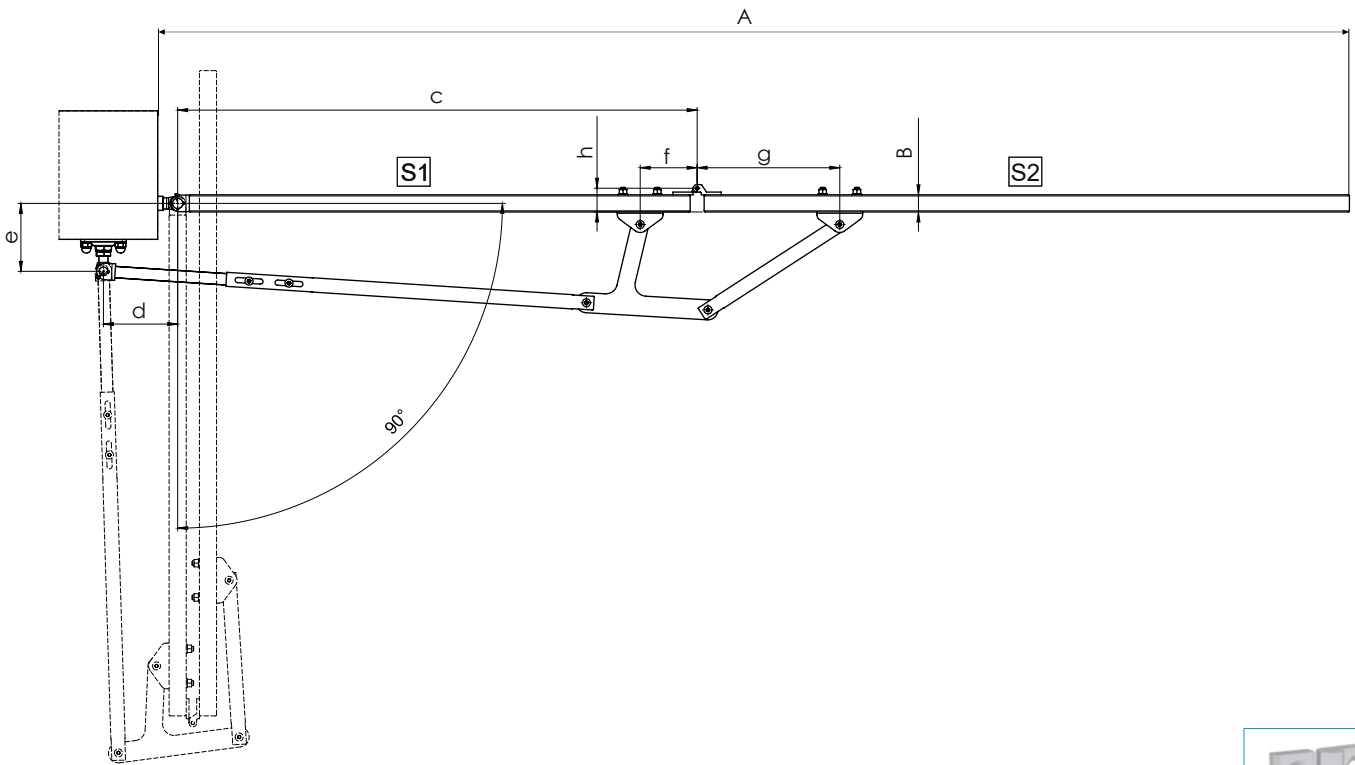

D16/77-60

Quality	Finish	art.	A	B	c	d	e	f	g	h
AISI304	raw	A-FS-110-D	1500-3000	30,40	750-1200	130	115	100	250	40
		A-FS-150/60-JP	1800-3500	50,60	900-1500	150	155	120	270	65

new

HINGES

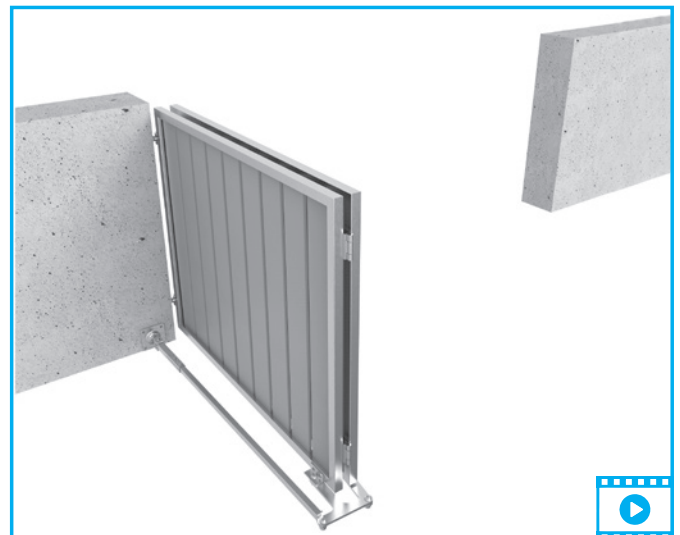

MODEL FOLDING

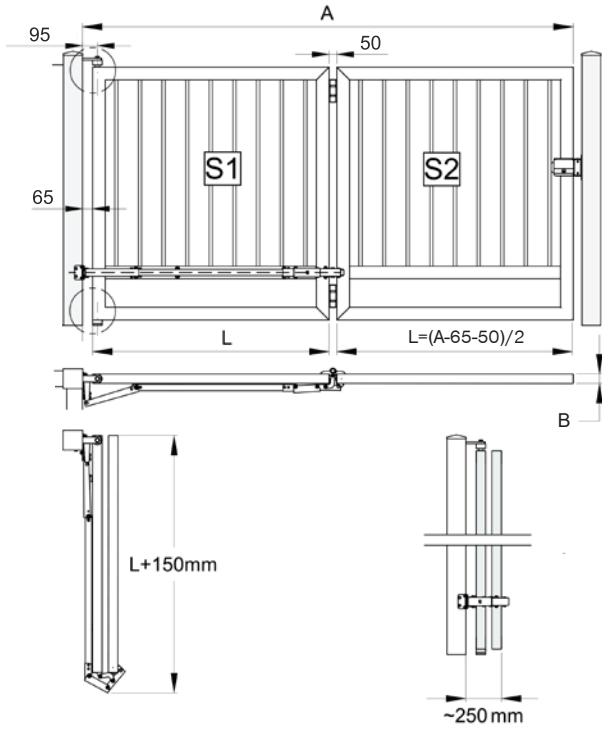

A	L	max S2 (kg)
2000	940	205
2500	1190	170
3000	1440	145
3500	1690	120
4000	1940	105
4500	2190	95
5000	2440	85

Quality	Finish	art.	A	B
Fe	Zn	FS-250	1900-5000	40/50/60

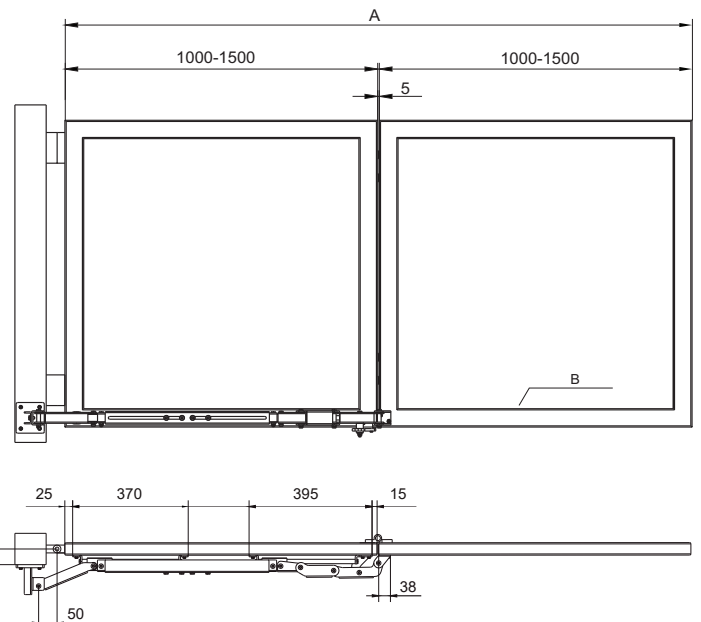
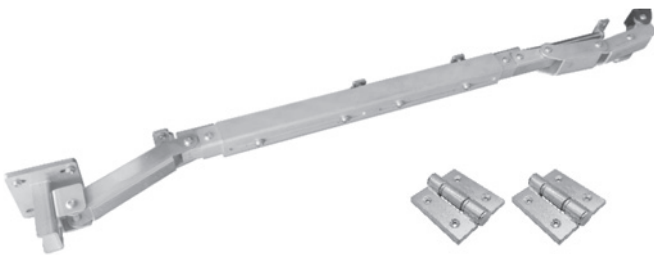

Quality	Finish	art.	A	B
Fe	Zn	FS-150	2000-3000	50/60

new

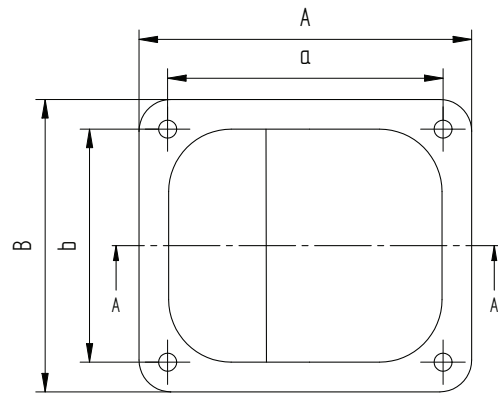
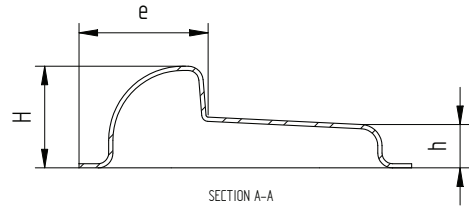

Quality	Finish	art.	A	a	B	b	H	h	e
Fe	Zn	B1/32	158	130	138	110	50	22	60
AISI304	raw	B8/32							
Fe	Zn	B1/32-S	120	95	100	75	42	20	45
AISI304	raw	B8/32-S							

top

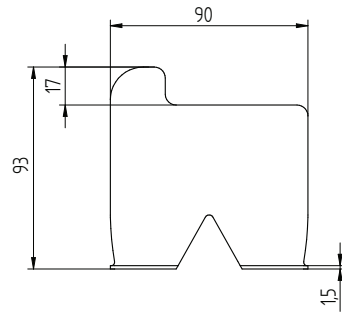

Quality	Finish	art.
Fe	Zn	B1/51

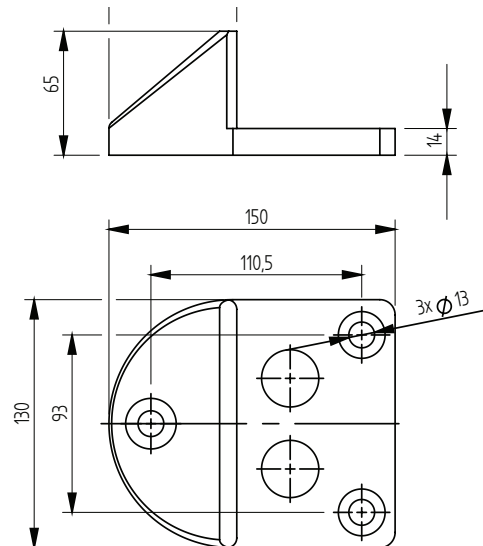
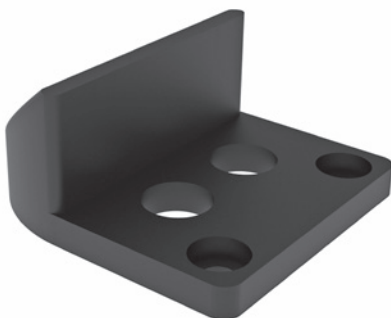

Quality	Finish	art.
Rubber	black	B1/32-G

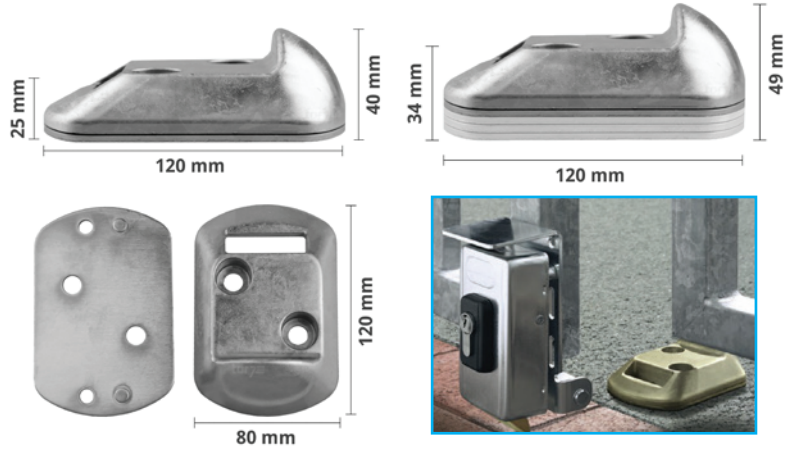

Quality	Finish	art.
Fe	Zn	B1/35-EL

new

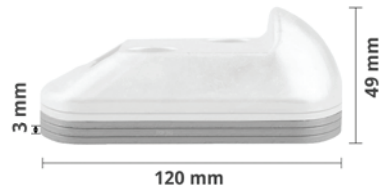

Quality	Finish	art.
Fe	Zn	B1/35-EL-PLATE

new

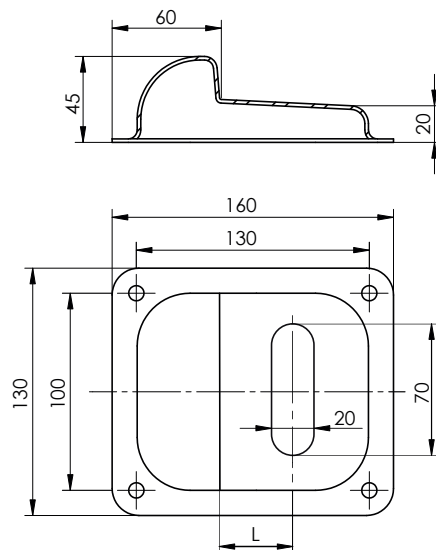

Quality	Finish	art.
Fe	Zn	B1/36-52,5
		B1/36-66

L
52,5
66

new
new

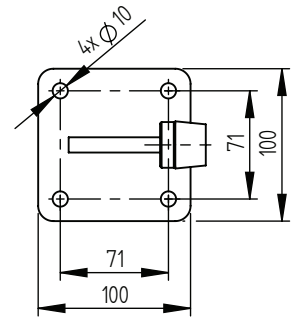
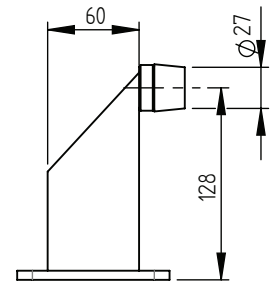

Quality	Finish	art.	Color
		H/10B-60x130	-
Fe	Zn	H/10B-60x130-BLACK	black
		H/10B-60x130-ANTHR	anthracite
AISI304	raw	H8/10B-60x130	-

new
new

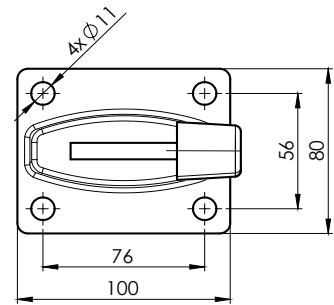
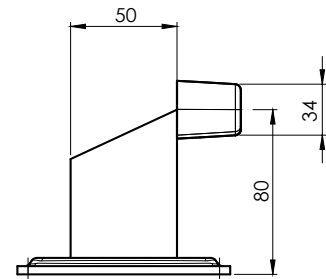
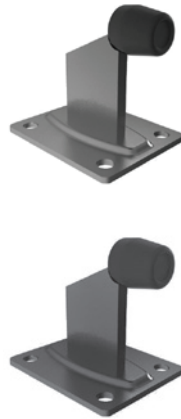

Quality	Finish	art.	Color
		H/10B-50x80	-
Fe	Zn	H/10B-50x80-BLACK	black
		H/10B-50x80-ANTHR	anthracite

new
new

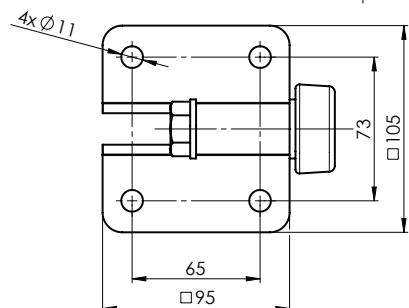
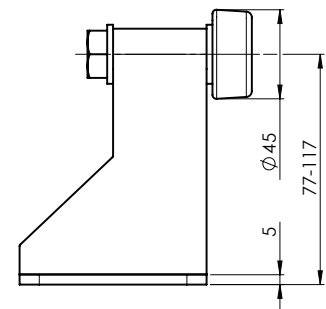

Quality	Finish	art.
Fe	Zn	H/10B-50x120

new



STOPPERS

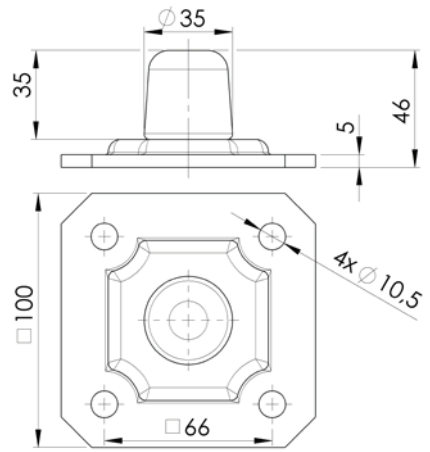
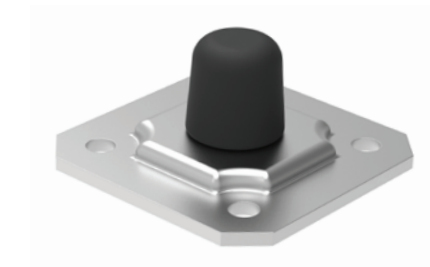

Quality	Finish	art.
Fe	Zn	H/10B-35x46

new

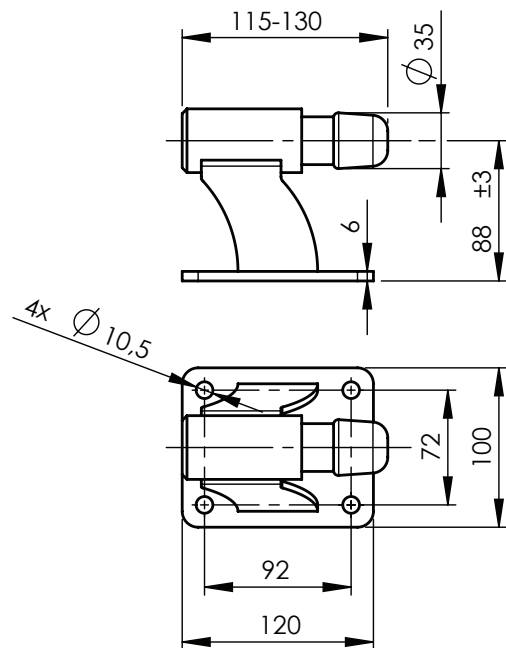

Quality	Finish	art.
Fe	Zn	H/10B-130x85-SPRING

new

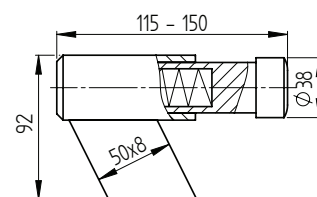
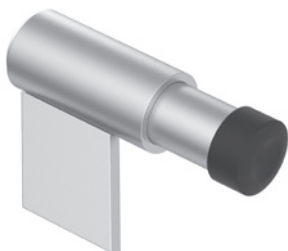

Quality	Finish	art.
Fe	Zn	H/10BP-150x92-SPRING

new



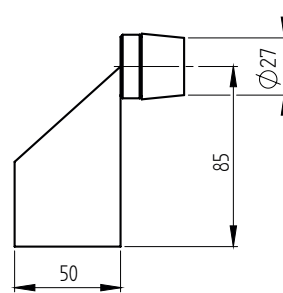

Quality	Finish	art.
Fe	Zn	H/10BP-50x100

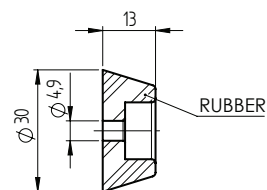

Quality	Finish	art.
Rubber	black	B1/16G

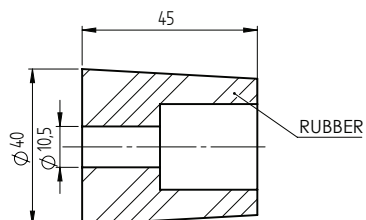

Quality	Finish	art.
Rubber	black	B1/16G-B



STOPPERS

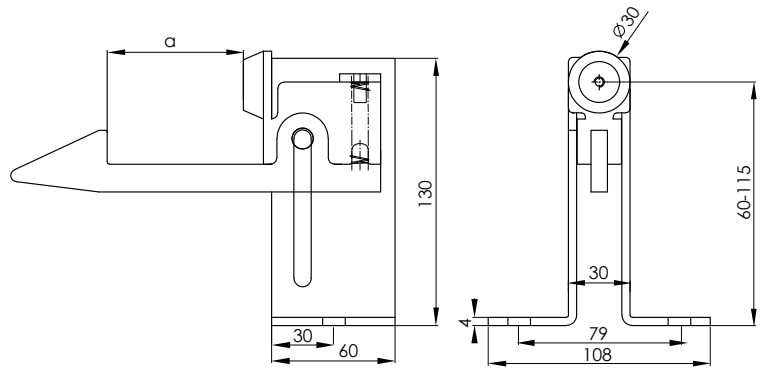

Quality	Finish	art.	a
Fe	Zn	H/58-43	43
		H/58-63	63

new
new

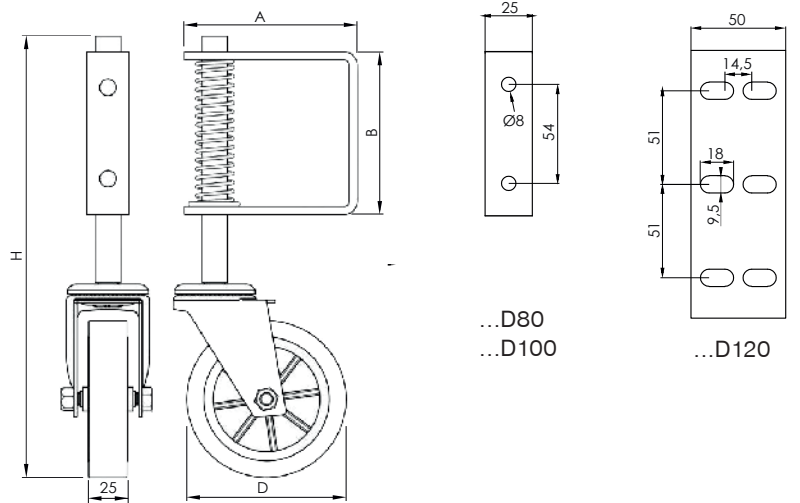

...D80
...D100

...D120

Quality	Finish	art.	D	H	A	B
Fe	Zn	H/PK01-D80	76	260	96	87
		H/PK01-D100	102	280	110	90
		H/PK01-D120	123	355	130	146

new
new
new



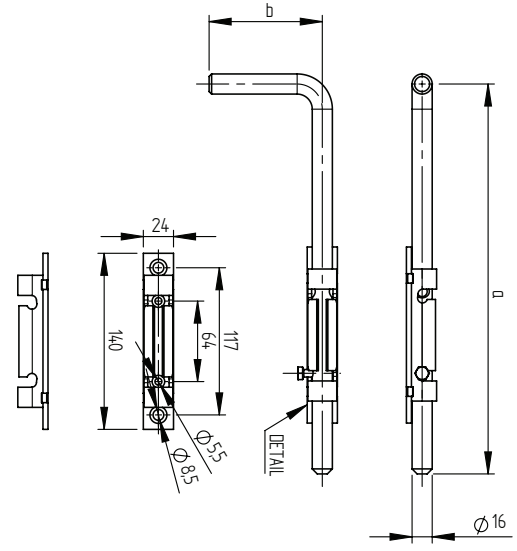

Quality	Finish	art.	a	b	
Fe	Zn	D7/12-200	200	82	
AISI304	raw	D8/12-300	300		
Fe	Zn	D7/12-300		90	✓ <i>top</i>
Fe	Zn	D7/12-500		500	
AISI304	raw	D8/12L-500			✓ <i>new</i>

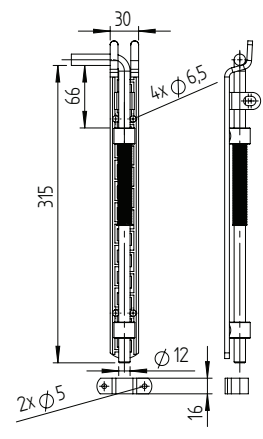

Quality	Finish	art.	
Fe	Zn	D7/24-315	✓

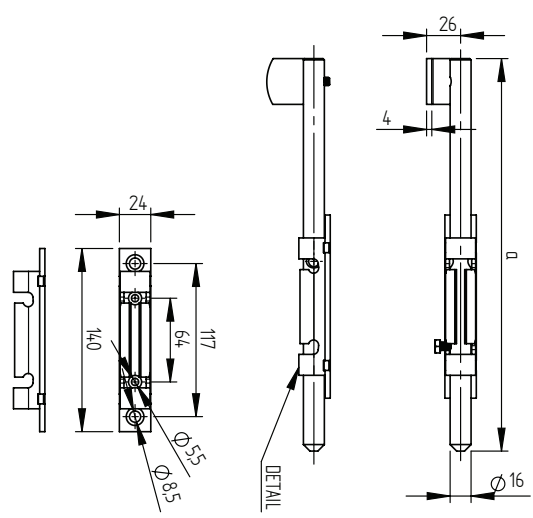

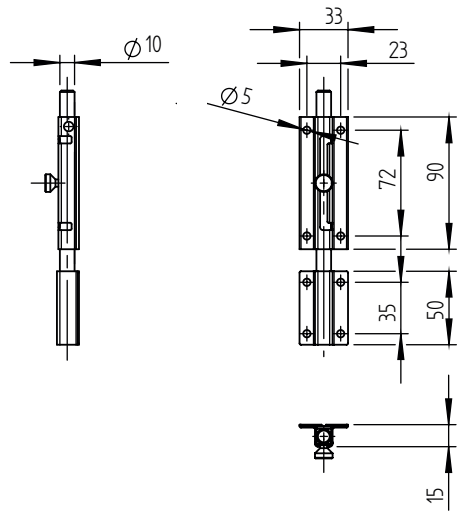

Quality	Finish	art.	a	
Fe	Zn	D7/19-300	300	✓
Fe	Zn	D7/19-500	500	

LATCHES

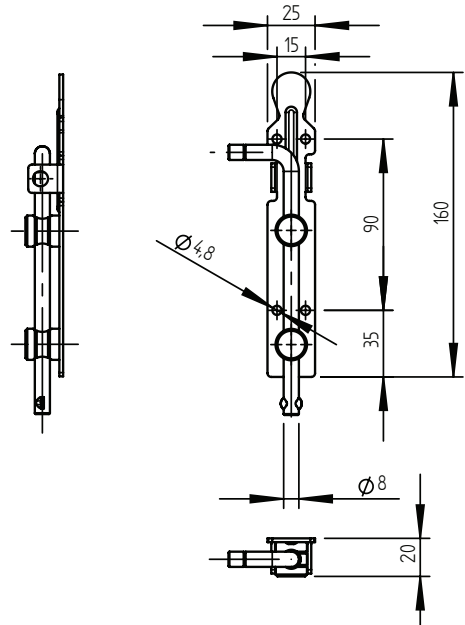

Quality	Finish	art.	
Fe	Zn	D7/16-150	✓



Quality	Finish	art.	
Fe	Zn	D7/17-160	✓

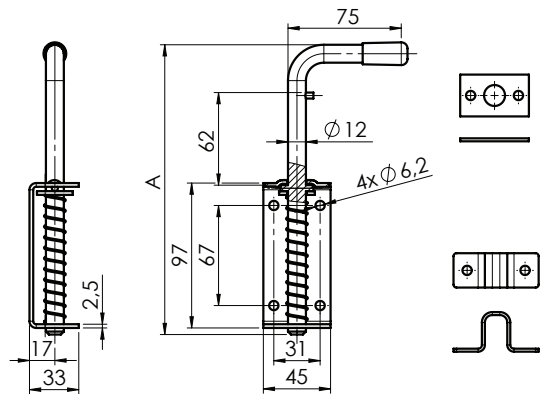

Quality	Finish	art.	A	
Fe	Zn	D7/25-200	200	-
		D7/25-300	300	
		D7/25-400	400	

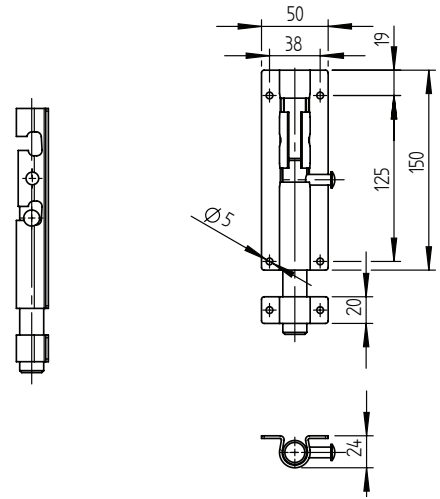

Quality	Finish	art.	
Fe	Zn	D7/23-150	✓

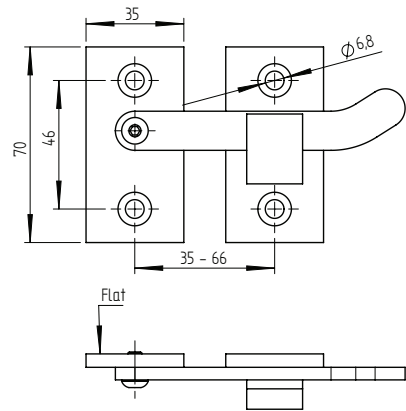

Quality	Finish	art.	Ø
AISI316	satin	D16/74-70-000	Flat

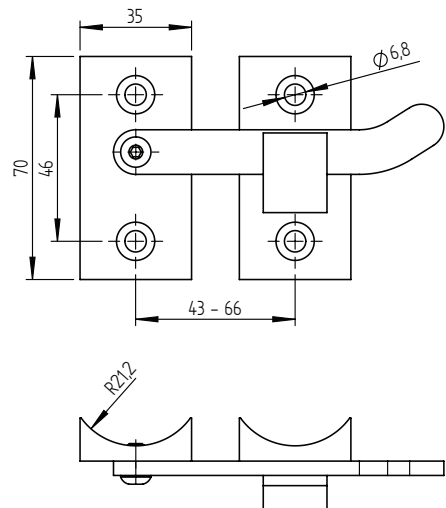

Quality	Finish	art.	Ø
AISI304	satin	D8/74-70-042	42,4
AISI316		D16/74-70-042	

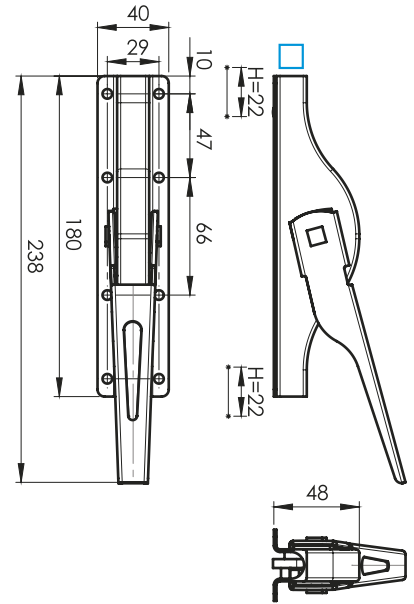

Quality	Finish	art.	TIAHLO (ROD)	
Fe	Zn	D7/22-180	12x12	-

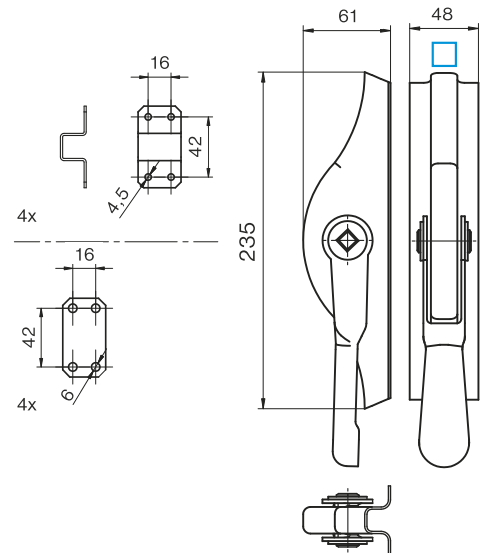

Quality	Finish	art.	TIAHLO (ROD)	
Fe	Zn	D7/22-235-Zn	14x14	-
	raw	D7/22-235-Fe		

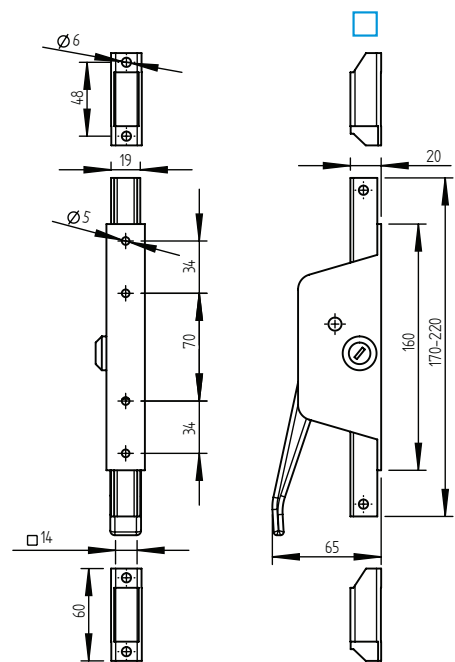

Quality	Finish	art.	TIAHLO (ROD)	
Fe	Zn	D7/22-160	14x14	✓

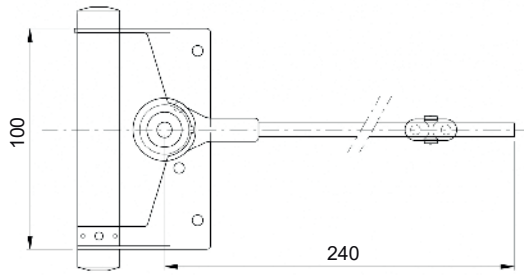
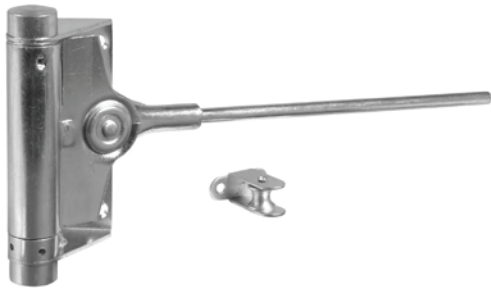

Quality	Finish	art.	Gmax/2pcs (kg)
Fe	raw	D10/01I-120	60

new

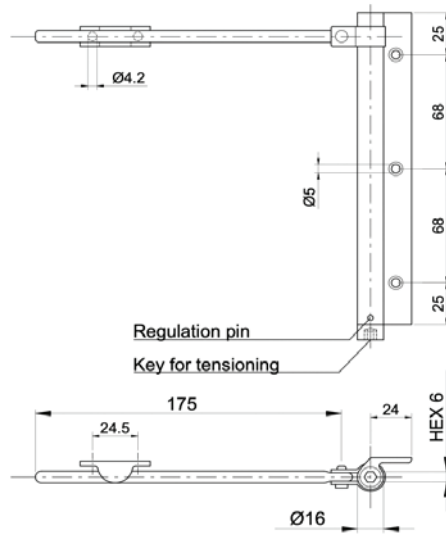

Quality	Finish	Color	art.	Gmax/2pcs (kg)
ALUMINIUM	natural	black	D10/03AL-190-BLACK	40
		grey	D10/03AL-190-GREY	

new

STOPPERS, LATCHES

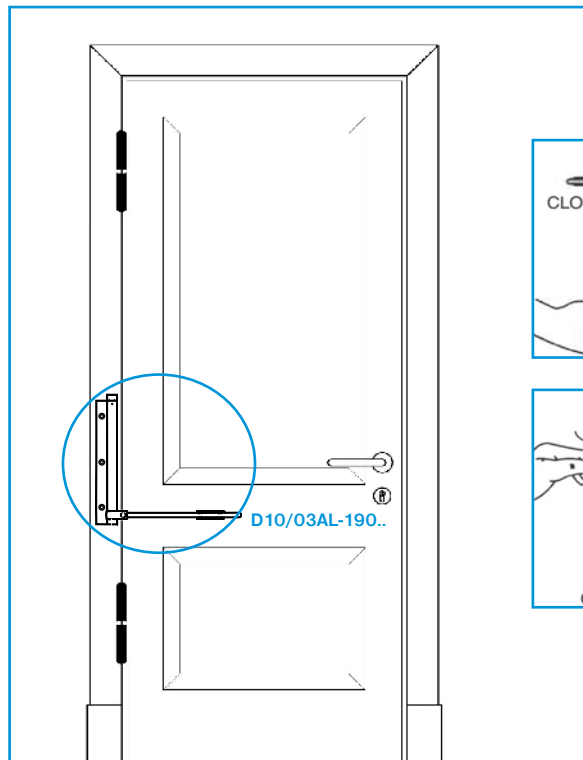
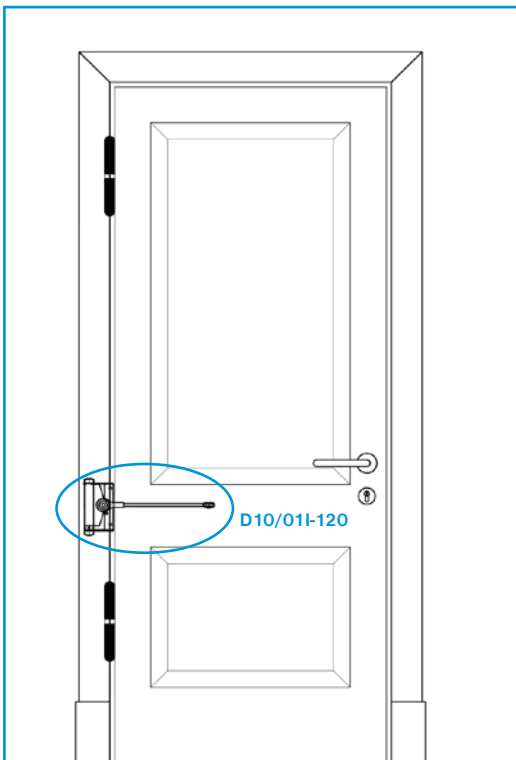

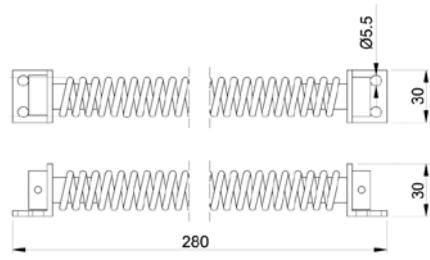

Quality	Finish	art.	Gmax/2pcs (kg)
AISI304	raw	D10/05I-280	60

new



Quality	Finish	art.	Norm	Dimensions	Door: ↔ /G/°max
ALUMINIUM	natural	WS/Z-101	EN1154, EN:2-3	230x33x57	1200mm/65kg/120°



Quality	Finish	Color	art.	Norm	Dimensions	Door: ↔ /G/°max
AISI304	satin	-	WS/Z-104	EN1154, EN:2-3	182x41x63	900mm/60kg/180°
ALUMINIUM	natural	black	WS-BLACK/Z-104			

new

LOCK SETS

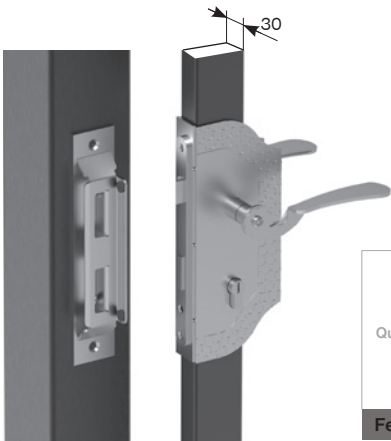

Quality	set								
Fe/Zn	BR/30x30-set S	B1/62U-40	B1/34-32A	D1/14AL	D1/14AR	B1/33-30	B1/30-50A	B1/19N	D2/28-Zn

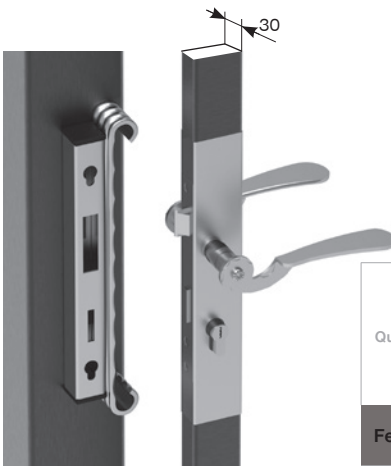

Quality	set								
Fe/Zn	BR/30x30-set BR/50x30-set	B1/07T-30	B1/09-50M	E2/258-30x30	B1/52J-30x30	B1/30-17x82	B1/30-35x90	B1/19N	D2/07-Zn



Quality	set					
Fe/Zn	BR/40x40-set BR/60x40-set BR/80x40-set	B1/62U-40	B1/58J-40x40 B1/58J-60x40 B1/58J-80x40	B1/30-22x90 B1/30-40x90 B1/30-50A	B1/19N	D2/28-Zn

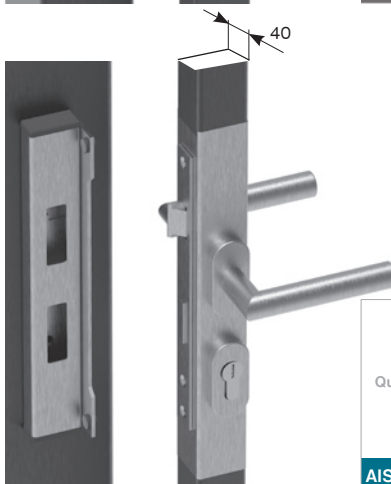











Quality	set					
AISI304	BR8/40x40-set	B8/62-40x20	B8/39J-40x40-A	B8/30-20x85	B1/19N	D8/05-i











LOCK SETS, BOXES

LOCK SETS











Quality	set	 12-24 Vac/Vdc										
Fe/Zn	BR/30x30-set ES	B1/18-LC	B1/61U-40	B1/34-32A	D1/14AL	D1/14AR	B1/33-30	B1/30-50A	B1/19N	D2/28-Zn	D5/11-Zn	D0/05-Zn











Quality	set	 6-14 Vac/Vdc									
Fe/Zn	BR/30x30-set E BR/50x30-set E	B1/18-I	B1/07T-30	B1/09-50M	E2/ 258-30x30	B1/52J-30x30 B1/58J-50x30	B1/30-17x82 B1/30-35x90	B1/19N	D2/07-Zn	D5/11-Zn	D0/05-Zn



Quality	set	 12-24Vac/Vdc								
Fe/Zn	BR/40x40-set E BR/60x40-set E BR/80x40-set E	B1/18-LC	B1/61U-40	B1/58J-40x40 B1/58J-60x40 B1/58J-80x40	B1/30-22x90 B1/30-40x90 B1/30-50A	B1/19N	D2/28-Zn	D5/11-Zn	D0/05-Zn	



Quality	set	 12-24Vac/Vdc							
AISI304	BR8/40x40-set E	B1/18-LC	B8/61-40x40	B8/39J-40x40-A	B8/30-20x85	B1/19N	D8/05-i	D8/04-i	

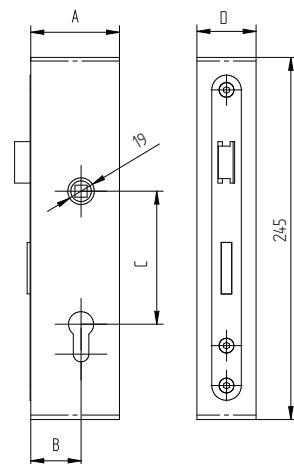

Quality	Finish	art.	A	B	C	D
Fe	raw	B1/60-40x40	40	21,5	90	40
		B1/59-50x30	50	34	72	30
		B1/59-60x40	60			40

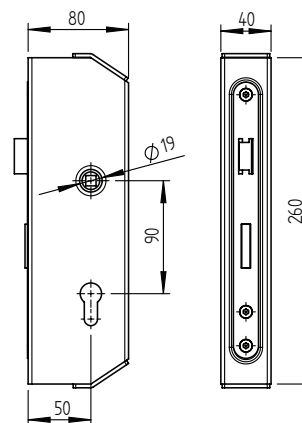
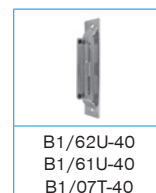

Quality	Finish	art.
Fe	raw	B1/48-80x40

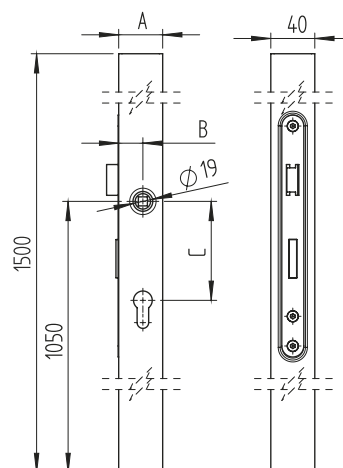
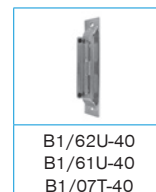

Quality	Finish	art.	A	B	C
Fe	raw	B1/63-40x40x1500	40	22	90
		B1/63-60x40x1500	60	34	72

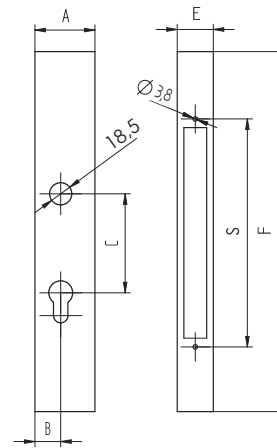

Quality	Finish	art.	A	B	C	E	F	s	
AISI304	satin	B8/58J-40x40	40	19		40		200	B1/30-22x90
		B1/58J-40x40							
Fe	raw	B1/58J-50x30	50	32,5	90	30	260	215	B1/30-35x90
		B1/58J-60x40	60	37,5					B1/30-40x90
		B1/58J-80x40	80	47					B1/30-50A
AISI304	satin	B8/39J-40x40-A	40	18,5	85		40	210	B8/30-20x85
		B8/39J-40x40							
		B1/39J-40x40							
Fe	raw	B1/39J-50x30	50			30	300		B1/30-20x85
		B1/52J-30x30	30	13					B1/30-17x82
		B1/52J-40x40	40	21,5	82	40		190	B1/30-25,5x82
		B1/52J-50x30	50			30			

new



Quality	Finish	art.	
AISI304	satin	B8/63-40x40x1500	B8/30-20x85

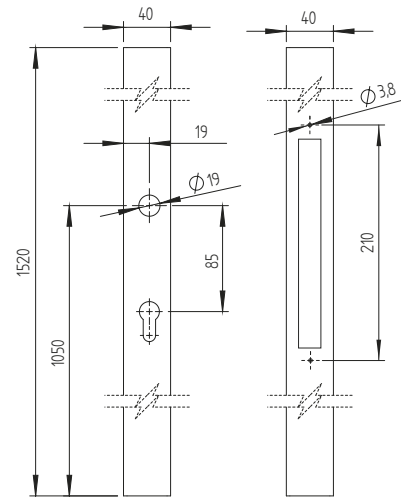

Quality	Finish	art.	
AISI304	satin	B8/63-D42x1500	B8/30-20x85

new



B1/58J-80x40

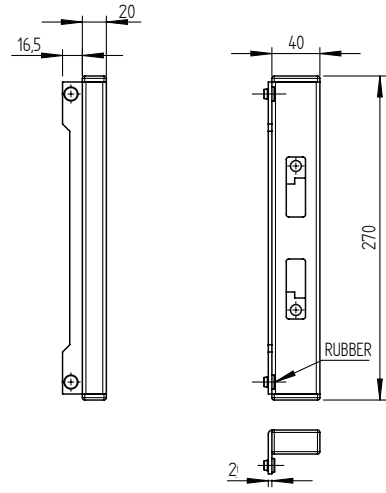

Quality	Finish	art.
AISI304	satın	B8/62-40x20

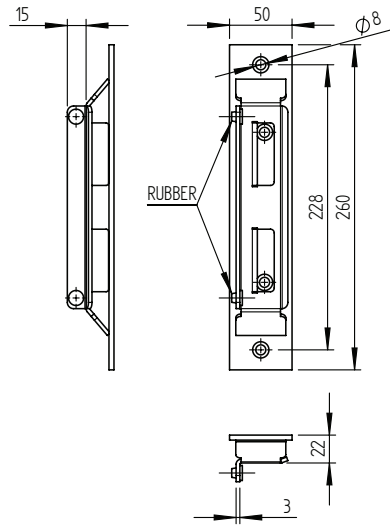

Quality	Finish	art.
Fe	Zn	B1/62U-40

top

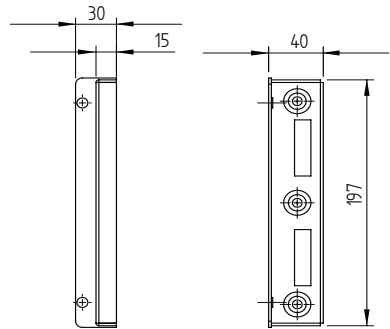

Quality	Finish	art.
Fe	Zn	B1/62U-40x30

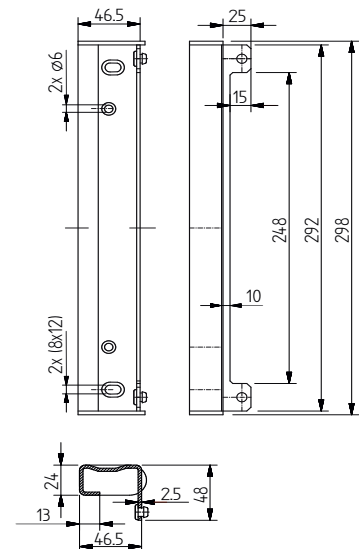

Quality	Finish	art.
Fe	Zn	B1/62U-45x45



Quality	Finish	art.
AISI304	satin	B8/61-40x40

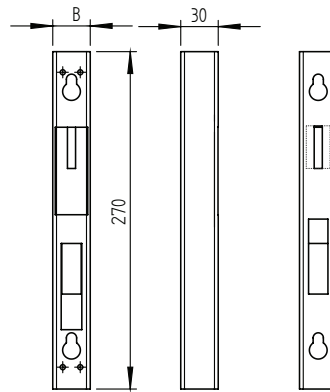
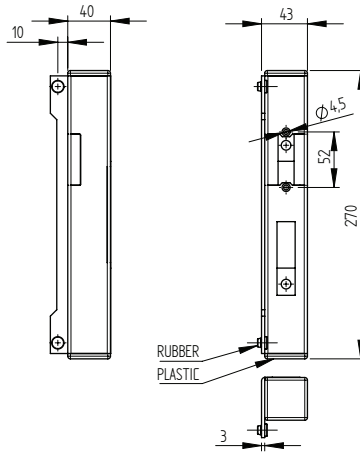

Quality	Finish	art.	B
Fe	raw	B1/07T-30	30
AISI304	satin	B8/07T-30	
Fe	raw	B1/07T-40	40
AISI304	satin	B8/07T-40	

Univerzálny doraz pre klasický alebo elektromagnetický zámok.
Universal stop box for classical or electromagnetic lock.

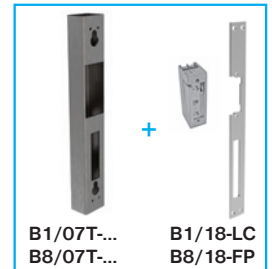

B1/61-46x36-L

B1/61-46x36-P

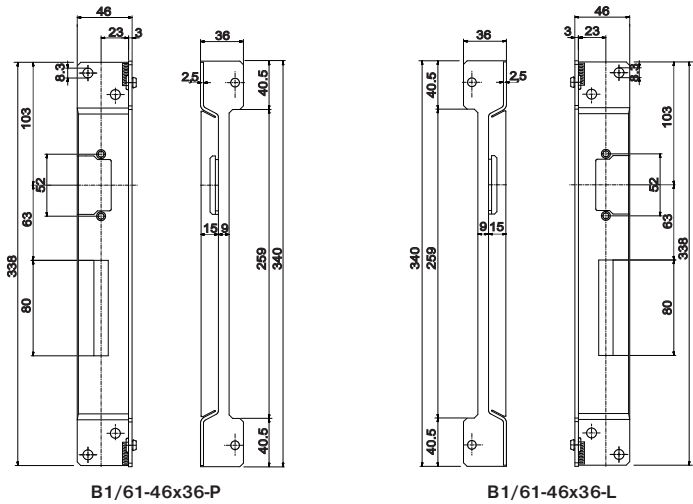

B1/61-46x36-P

B1/61-46x36-L

Quality	Finish	art.
Fe	Zn	B1/61-46x36-P
		B1/61-46x36-L

new

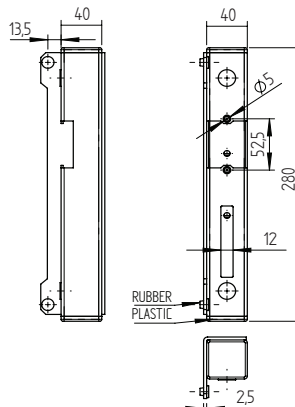

Quality	Finish	art.
Fe	Zn	B1/61U-40



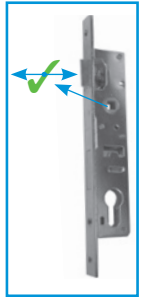
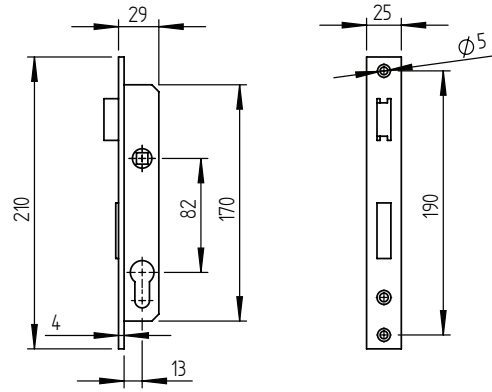

Quality	Finish	art.
Fe	Zn	B1/30-17x82

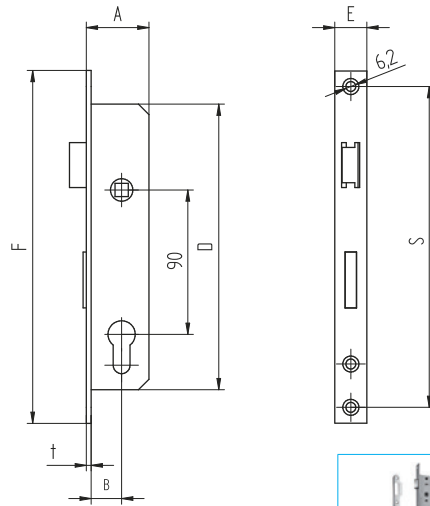

B1/30-22x90	B1/58J-40x40 B8/58J-40x40
B1/30-25x90	-
B1/30-35x90	B1/58J-50x30
B8/30-25x90	-
B8/30-35x90	-

Quality	Finish	art.	A	B	D	E	F	s	t
Fe	Zn	B1/30-22x90	39	19	178	20	220	200	3
		B1/30-25x90	40	22,5	175		235	216	
AISI304	satin	B8/30-25x90			180	22	240	210	2,5
Fe	Zn	B1/30-35x90	50	32,5	177		235	216	
AISI304	satin	B8/30-35x90			180		240	210	

*new
top
new*

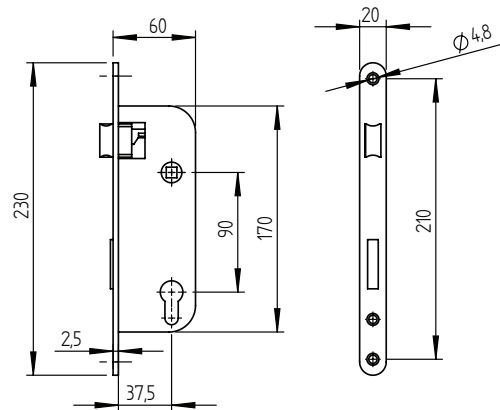

Quality	Finish	art.
Fe	Zn	B1/30-40x90

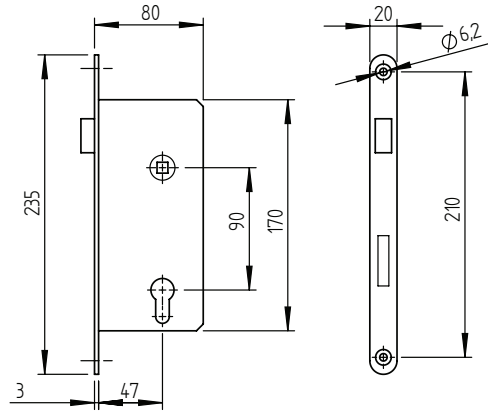

Quality	Finish	art.
Fe	Zn	B1/30-50A

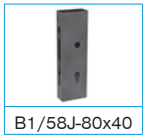

B1/58J-80x40



B1/30-20x85



B8/30-20x85
B8/30-30x85

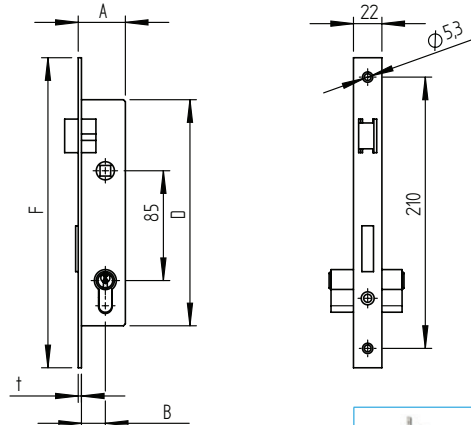

Quality	Finish	art.	A	B	D	F	t
Fe	Zn	B1/30-20x85	36,5	18,5	174	240	2,5
AISI304	satın	B8/30-20x85	35	18	170	238	3
		B8/30-30x85	45	27			

new

B1/30-20x85	B1/39J-40x40 B1/39J-50x30 B8/39J-40x40
B8/30-20x85	B8/39J-40x40-A
B8/30-30x85	-

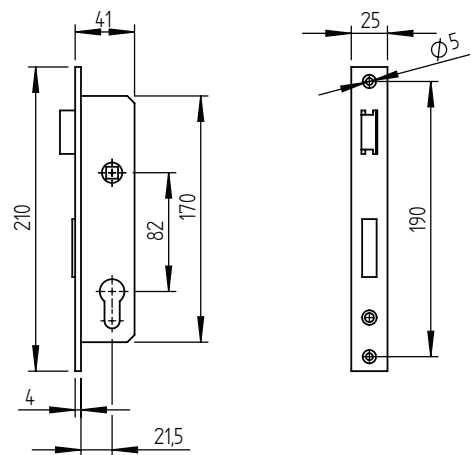

Quality	Finish	art.
Fe	Zn	B1/30-25,5x82



B1/52J-40x40
B1/52J-50x30

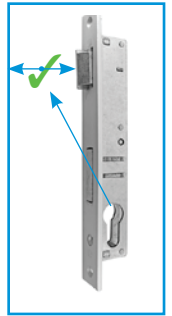
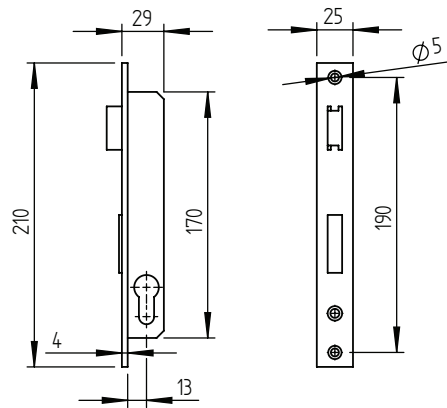

Quality	Finish	art.
Fe	Zn	B1/30-17G

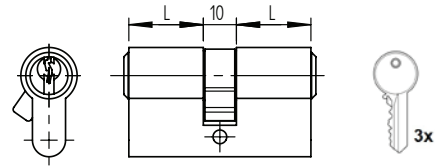

Quality	Finish	art.	L
BRASS	Ni	B1/19N	22,5
		B1/19N-60	25
		B1/19N-70	30
		B1/19N-80	35

new

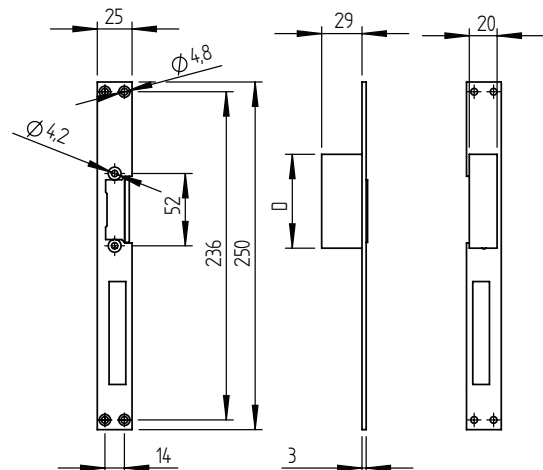

Quality	Finish	art.	D	Power supply
Fe	Zn	B1/18-I	68	6-14 Vac/Vdc
AISI304	raw	B8/18-LC	79	12-24 Vac/Vdc
		B8/18-F		

*new
new*

V kludovom stave zablokovany/Locked in default state

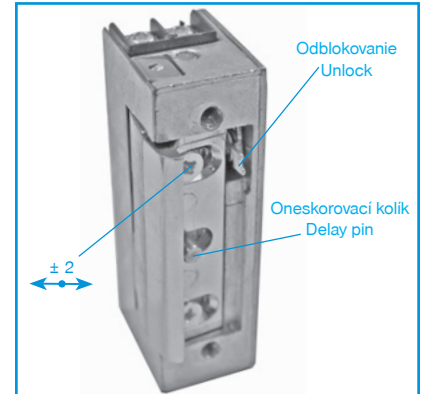
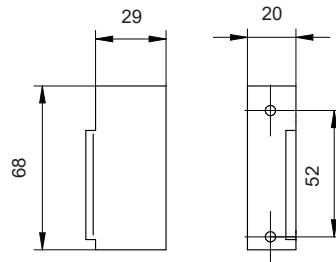

Quality	Finish	art.	Power supply
Fe	Zn	B1/18-LC	12-24 Vac/Vdc

V kludovom stave zablokovaný/Locked in default state

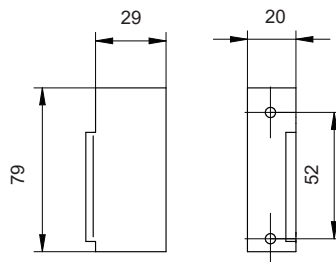

Quality	Finish	art.	Power supply
Fe	Zn	B1/18-F	12-24 Vac/Vdc

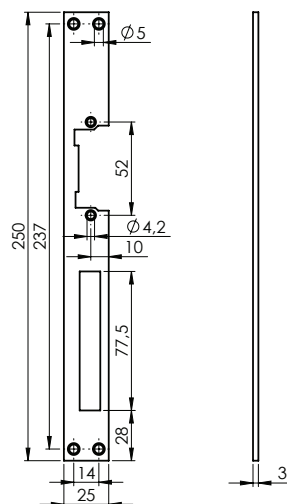

Quality	Finish	art.
AISI304	raw	B8/18-FP

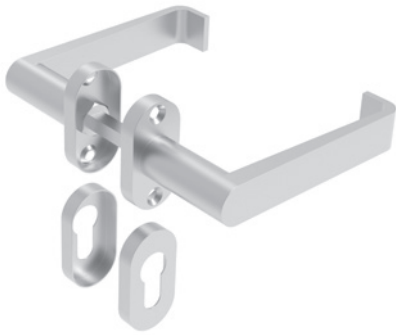

Quality	Finish	art.	Model
AISI304	satın	D8/15-i	K01

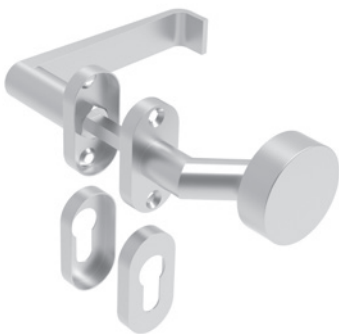
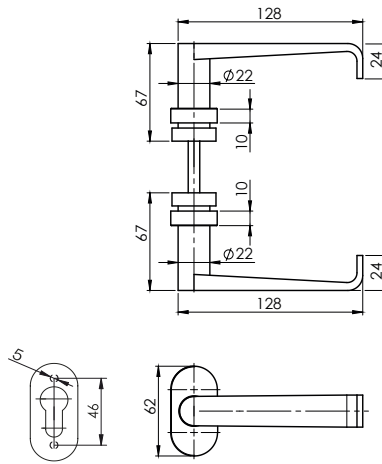

Quality	Finish	art.	Orientation	Model
AISI304	satın	D8/15G-R-i	right	K02, K11
		D8/15G-L-i	left	

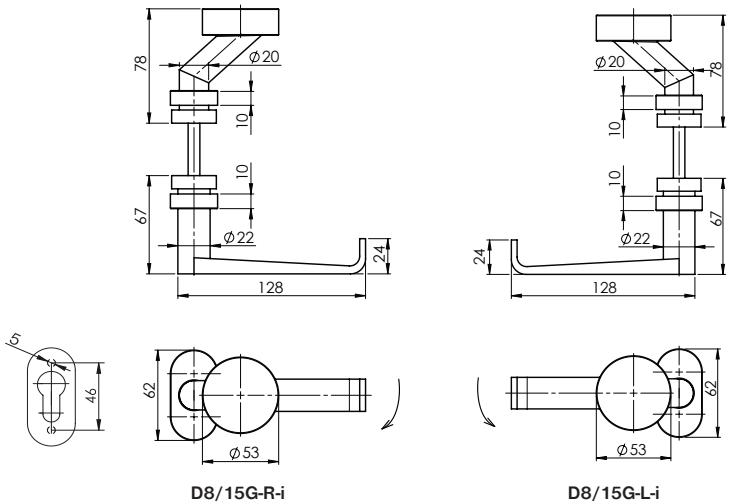

D8/15G-R-i

D8/15G-L-i



Quality	Finish	art.	Model
AISI304	satın	D8/014-i	K320

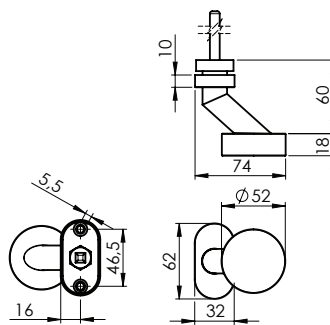

HANDLES

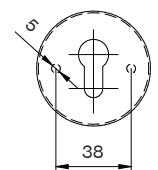
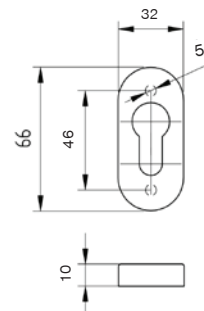

Quality	Finish	art.	Model
AISI304	satın	D8/09-i	K01
		D8/09B-i	
		D8/08-i	
		D8/08B-i	
		D8/08-WC	
		D8/09-WC	

new
new
new

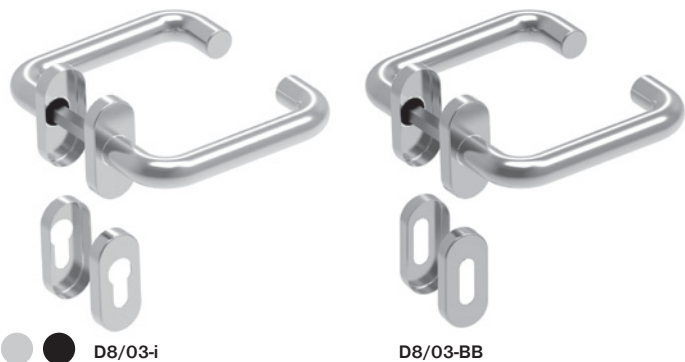

● D8/03-i

D8/03-BB

Quality	Finish	Color	art.	Model
AISI304	satin	-	D8/03-i	K02
	RAL	black	D8/03-BLACK	
AISI201	satin	-	D8/03-BB	

new

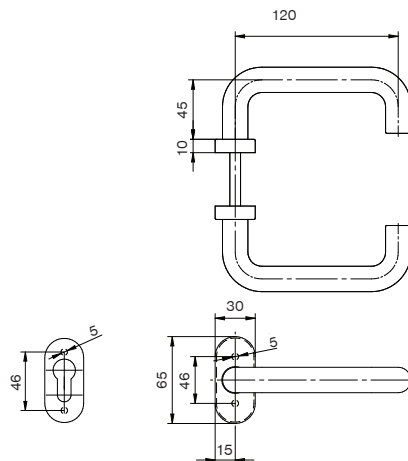

D8/01-i

D8/01-BB

Quality	Finish	art.	Model
AISI304	satin	D8/01-i	K02
AISI201		D8/01-BB	

new

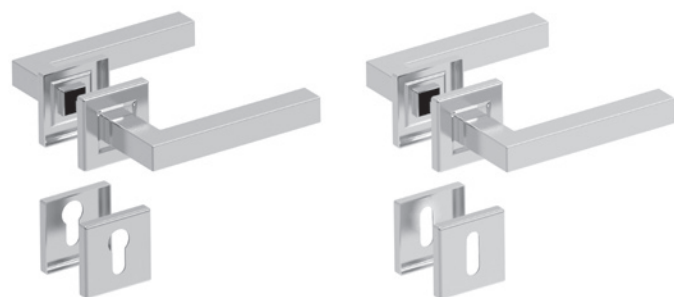
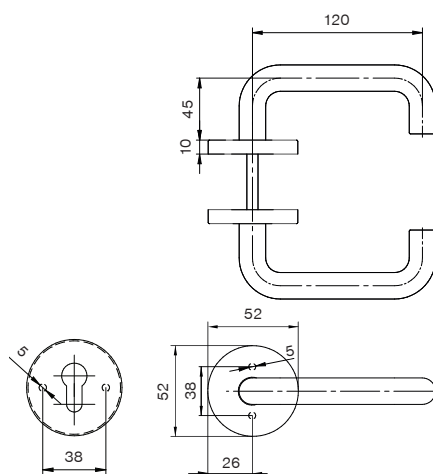

D8/06-i

D8/06-BB

Quality	Finish	art.	Model
AISI304	satin	D8/06-i	K01
AISI201		D8/06-BB	

new

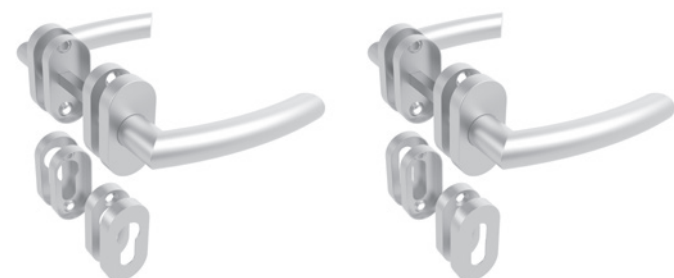
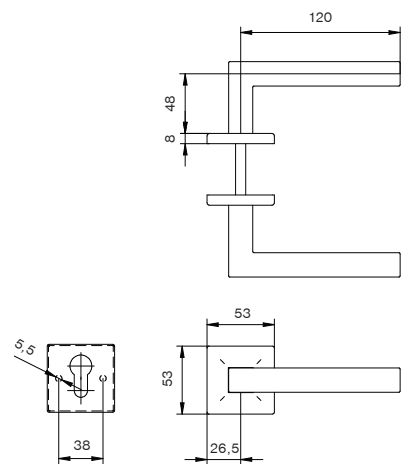

D8/010-i

D8/010-BB

Quality	Finish	art.	Model
AISI304	satin	D8/010-i	K01
AISI201		D8/010-BB	

new

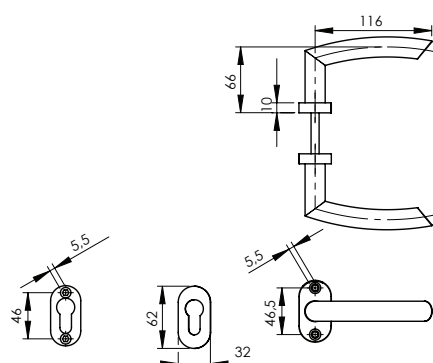

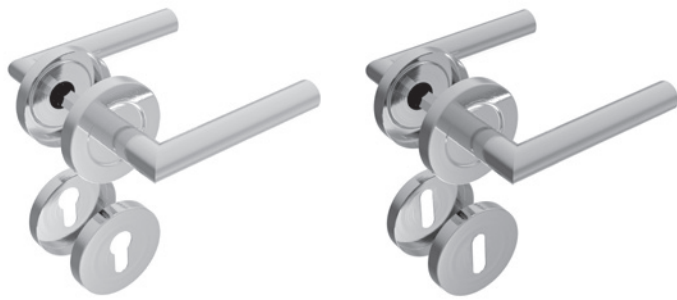

D8/02-i

D8/02-BB

Quality	Finish	art.	Model
AISI304	satin	D8/02-i	K02
AISI201	satin	D8/02-BB	

new

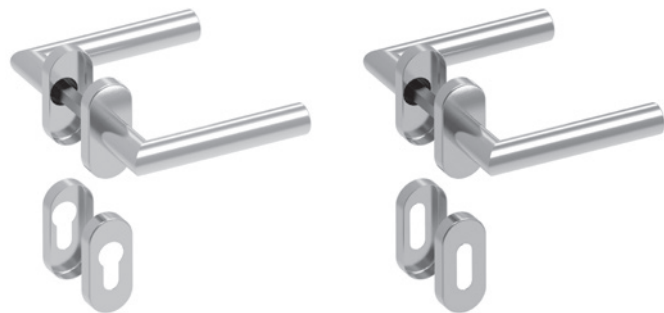
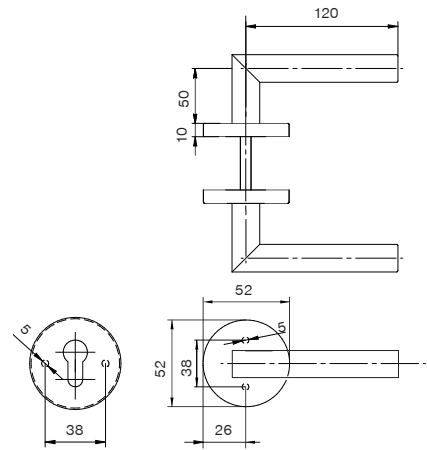

D8/05-i

D8/05-BB

Quality	Finish	Color	art.	Model
AISI304	satin	-	D8/05-i	K02
AISI201	satin	-	D8/05-BB	
AISI304	RAL	black	D8/05-BLACK	K02
AISI201	satin	-	D8/05-BB	

new

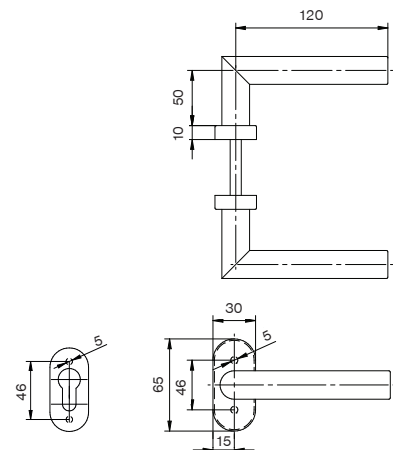

Quality	Finish	art.	Orientation	Icon	Model
AISI304	satin	D8/05G-R-i	right	fixed position	K02, K11
		D8/05G-L-i	left		
		D8/05-GR	right	opens together with handle	
		D8/05-GL	left		

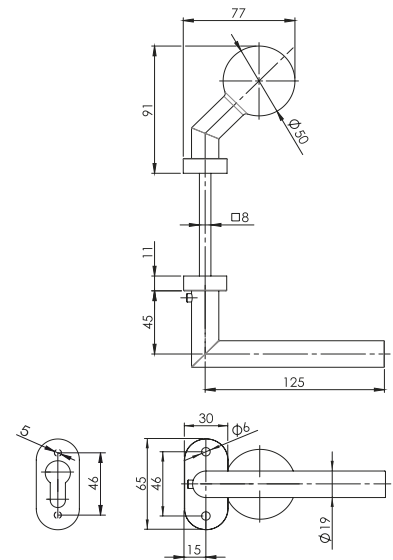

Quality	Finish	Color	art.	Icon 1	Icon 2	Model
AISI304	satin	-	D8/04-i	fix	-	K01
			D8/04-2-i	fix	fix	
			D8/04-2-R-i	open	fix	
			D8/04-2-L-i	fix	open	
			D8/04O-2-i	open	open	
RAL	black	D8/04-BLACK	fix	-		

new

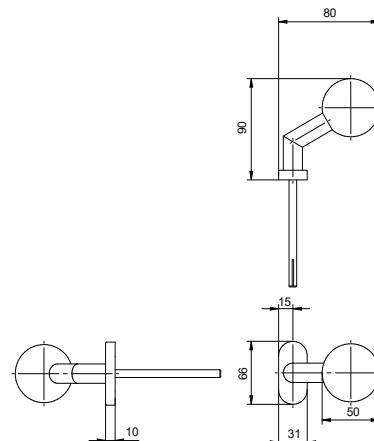



D2/07-Zn



D2/05T-Zn



D2/11-Zn



D2/56



D2/34-Zn



D2/57



D2/28-Zn



D2/52-Zn

Quality	Finish	art.	A	B	C	D	X	H	Model
Fe	Zn	D2/07-Zn	145	60	19		42	12	K11
		D2/11-Zn	132	45	48		28	15	
		D2/34-Zn	152	50	40	17,5	34		K12
		D2/28-Zn	145	42	37		36	17	
		D2/05T-Zn	143	60	35		41		K13
		D2/52-Zn	145	45	35		49		
	raw	D2/56	150	48	40	19	37	18	K14
		D2/57	160	54	50		25	19	

top

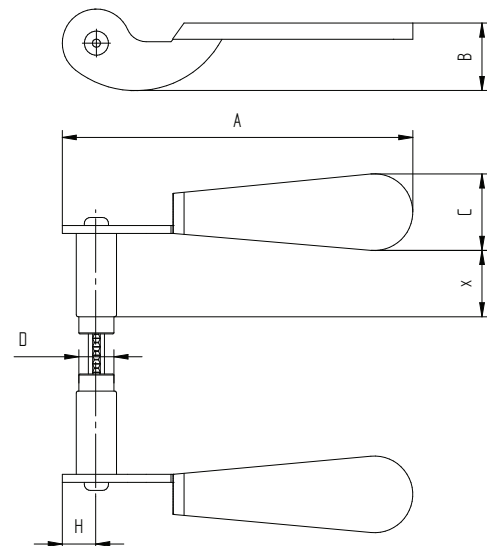

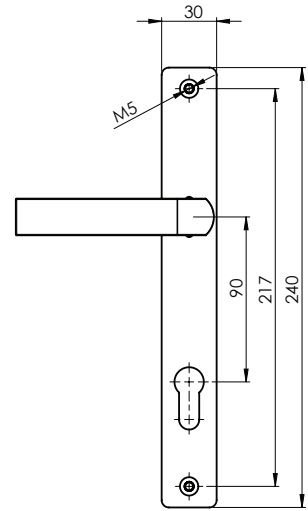
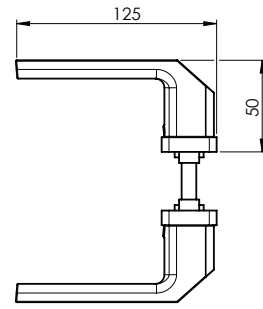

Quality	Finish	Color	art.
ZAMAK	RAL	black	D12/08-90

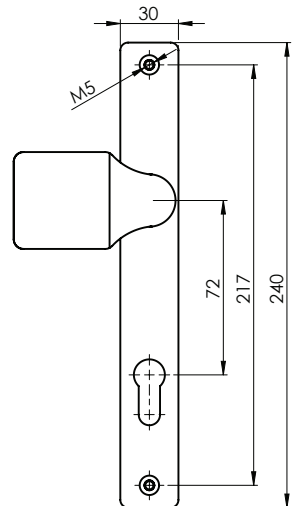
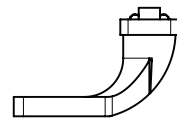
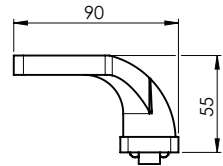

Quality	Finish	Color	art.
ZAMAK	RAL	black	D12/15-90

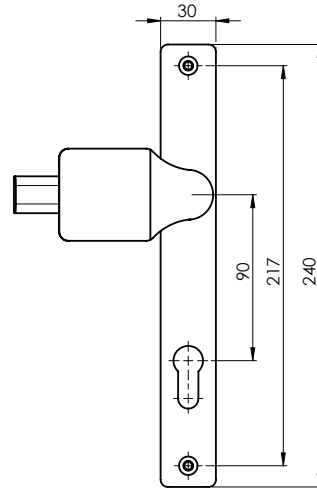
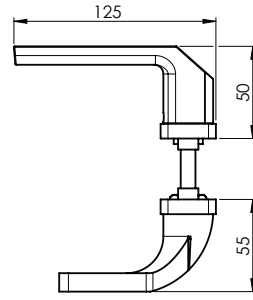

Quality	Finish	Color	art.
ZAMAK	RAL	black	D12/16-90

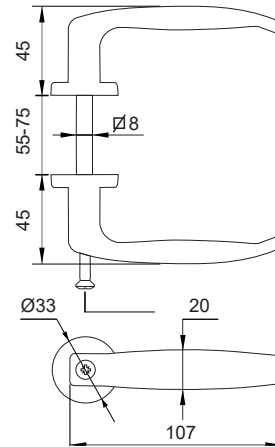

Quality	Finish	Color	art.	Model
ALUMINIUM	RAL	black	D2/29	K03

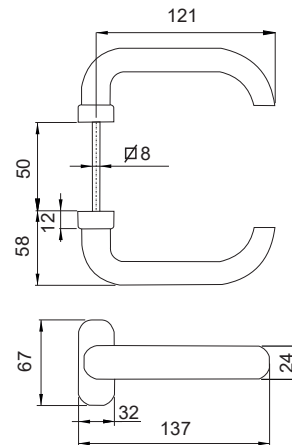

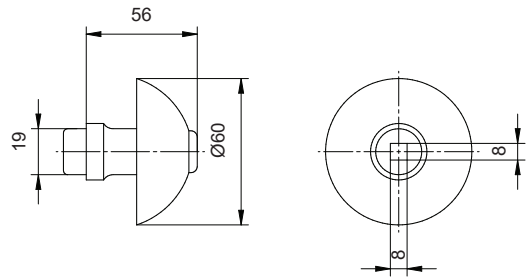

Quality	Finish	art.	Model
PVC	raw	D2/30	K03

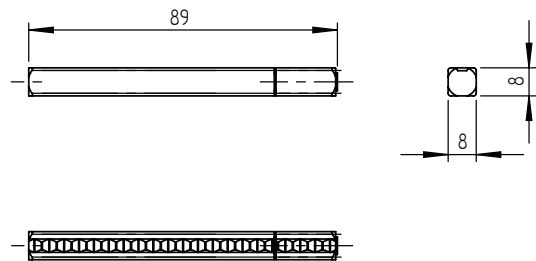
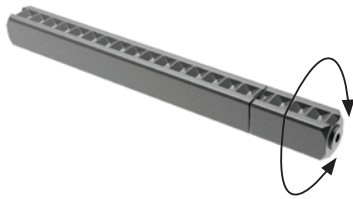

Quality	Finish	art.		Model
Fe	raw	D5/11-Fe	D0/03	K12
	Zn	D5/11-Zn	D0/05	

top
top



Quality	Finish	art.	
Fe	raw	D0/05-Zn	D5/11...

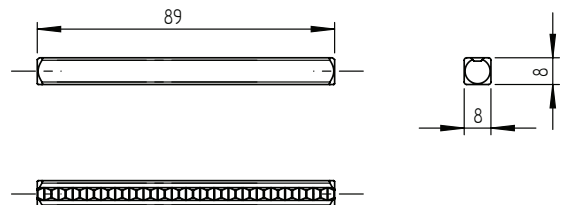
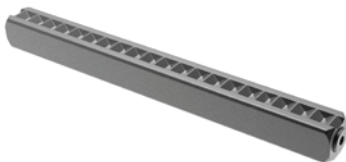

Quality	Finish	art.
Fe	raw	D0/03-Zn

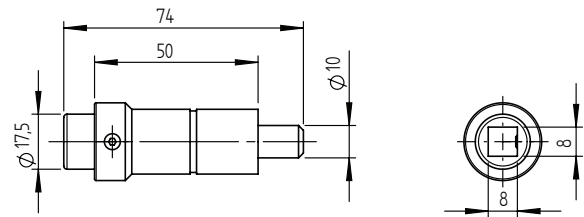

Quality	Finish	art.
Fe	raw	D0/01

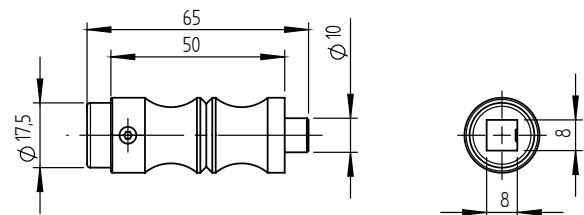

Quality	Finish	art.
Fe	raw	D0/04



D9/10-93x65



D9/10-93x65-INOX

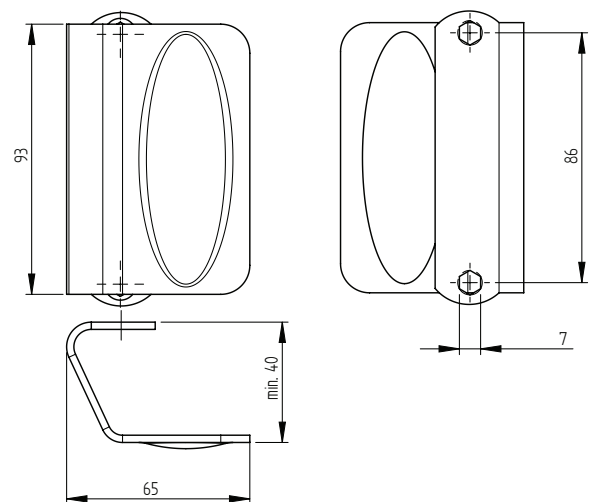

Quality	Finish	art.
Fe	raw	D9/10-93x65
AISI304	satin	D9/10-93x65-INOX



D1/39F



D8/09-i

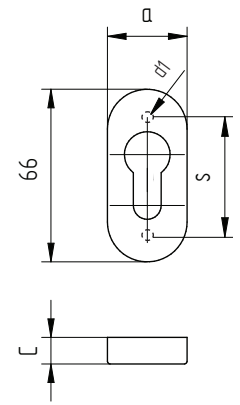

Quality	Finish	Color	art.	a	s	d1	C	Model
PVC	black	-	D1/39F	31	48	3,8	3,5	K02
	satın		D8/09-i					
AISI304	RAL	black	D8/09-BLACK	30	50	5	10	



D1/46K



D1/46F



D8/08-i

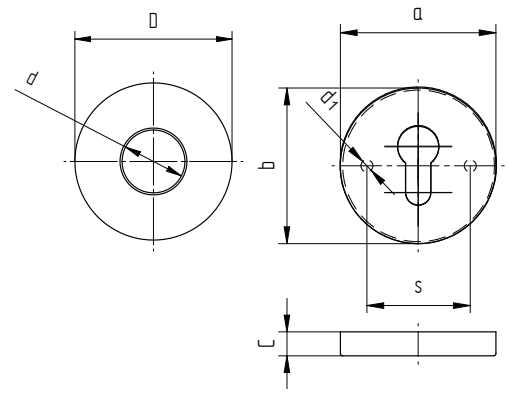

Quality	Finish	art.	a	b	D	s	d	d1	C	Model
Fe	raw	D1/46K	-	-	50	-	21	-	4	K13
		D1/46F								
AISI304	satın	D8/08-i	52	52	-	38	-	5	10	K01

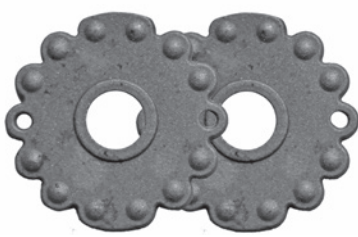

D1/32K

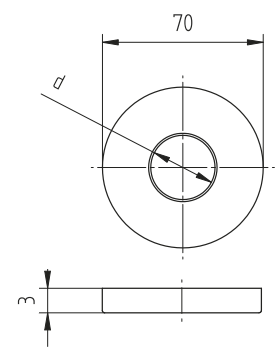

Quality	Finish	art.	d	Model
Fe	raw	D1/32K	18	K11, K12

LOCK COVER PLATES



D1/55-90



D1/18-90

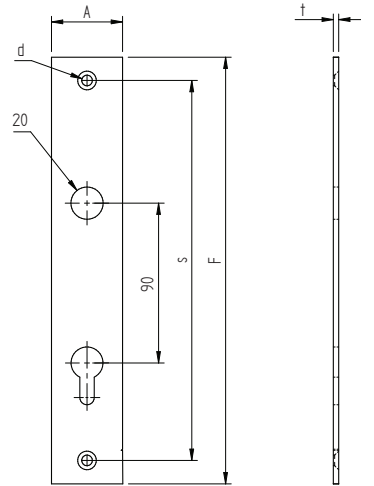

Quality	Finish	art.	A	F	s	d	t	Model
Fe	raw	D1/55-90	60	260	225	5	3	K13
		D1/18-90	47	245	188	5,2	2	



D1/02

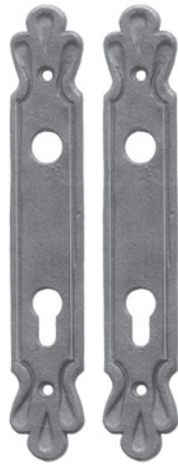

D1/19



D1/03

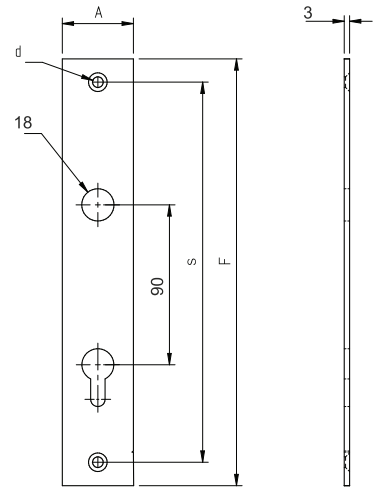

Quality	Finish	art.	A	F	s	d	Model
Fe	Zn	D1/02	40	240	215	5,5	K11, K12
		D1/19	40	278	200	6,5	
		D1/03	50	240	213	6	

top

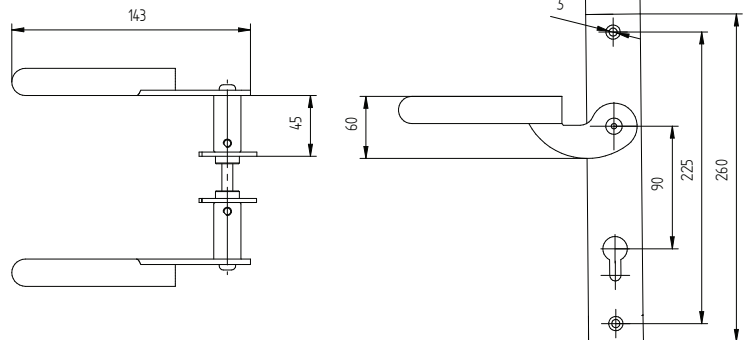

Quality	Finish	art.
Fe	raw	D12/07-90





D1/14AL

D1/14AR

D1/14A-S

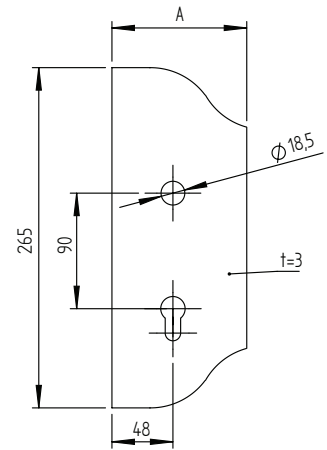
D1/14A-S-T



Quality	Finish	art.	A	Model	
Fe	raw	D1/14AL	105	K01 - K03	BR/30x30-set S BR/30x30-set ES
		D1/14AR		K11, K12	
		D1/14A-S		K21 - K23	
		D1/14A-S-T	-	-	

top
top

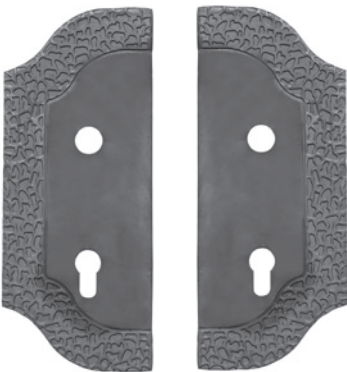

D1/14AL-T90

D1/14AR-T90

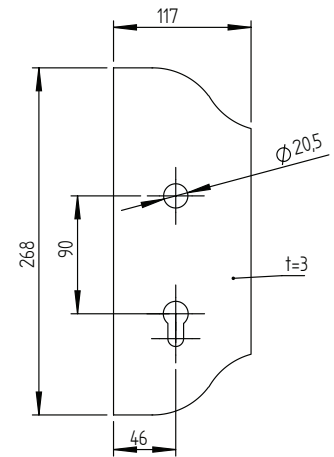

Quality	Finish	art.	Model
Fe	raw	D1/14AL-T90	K01 - K03
		D1/14AR-T90	K13
		D1/14AR-T90	K21 - K23

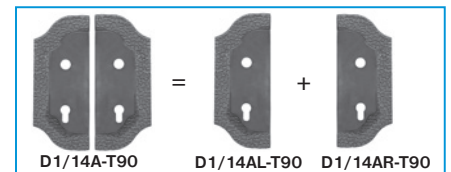

D1/14H2
D1/14H3

D1/14H3-S

D1/65H2

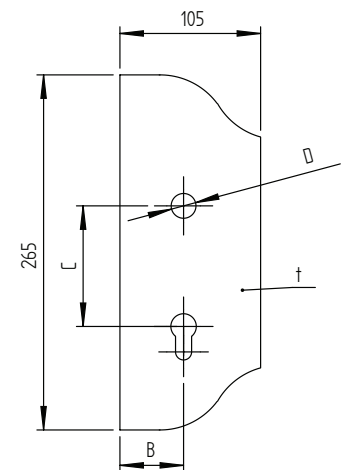

Quality	Finish	art.	B	C	D	t	Model
Fe	raw	D1/14H3	48	90	19	3	K01-K03, K11, K12, K21 - K23
		D1/14H3-S	-	-	-		-
		D1/65H2	48	90	18,5		2

												
		D	-	-	-	D17	D17	D19	D19	-	19	D19,5
		Hmax	26	15	18	15	17	17	19	15	30	35
		Model	K01	K02	K03	K11	K12	K13	K14	K21	K22	K23
	BR/30x30-set (E)				✓							
	BR/30x30-set S(E)				✓	✓						
	BR/50x30-set (E)				✓	✓						
	BR/40x40-set (E)	✓	✓	✓	✓	✓			✓		✓	
	BR/60x40-set (E)	✓	✓	✓	✓	✓			✓		✓	
	BR/80x40-set (E)	✓	✓	✓	✓	✓			✓		✓	
	B1/52J-30x30				✓							
	B1/39J-50x30		✓		✓				✓			
	B1/52J-50x30		✓	✓	✓	✓			✓			
	B1/58J-50x30	✓	✓	✓	✓	✓			✓			
	B1/39J-40x40, B8/58J-40x40		✓		✓				✓			
	B1/58J-40x40		✓		✓				✓			
	B1/52J-40x40		✓	✓	✓	✓			✓			
	B1/60-40x40		✓	✓	✓	✓			✓			
	B1/58J-60x40	✓	✓	✓	✓	✓			✓			
	B1/59-60x40	✓	✓	✓	✓	✓			✓			
	B1/58J-80x40	✓	✓	✓	✓	✓			✓		✓	
	B1/48-80x40	✓	✓	✓	✓	✓			✓		✓	
	D1/14AL, D1/14AR	✓	✓	✓	✓	✓			✓	✓	✓	
	D1/14H2, D1/14H3	✓	✓	✓	✓	✓			✓	✓	✓	
	D1/14AL-T90, D1/14AR-T90	✓	✓	✓			✓	✓	✓	✓	✓	
	D1/34-L-t2, D1/34-R-t2	✓	✓	✓			✓	✓	✓	✓	✓	
	D1/35-L-90, D1/35-R-90	✓	✓	✓			✓	✓	✓	✓	✓	
	D1/39F		✓									
	D8/09-i		✓									
	D1/46K, D1/46F						✓	✓		✓		
	D8/08-i	✓										
	D1/32K, D1/32F				✓	✓						
	D1/55-90						✓	✓		✓		
	D1/18-90						✓	✓		✓		
	D1/02				✓	✓						
	D1/03				✓	✓						
	D1/19				✓	✓						

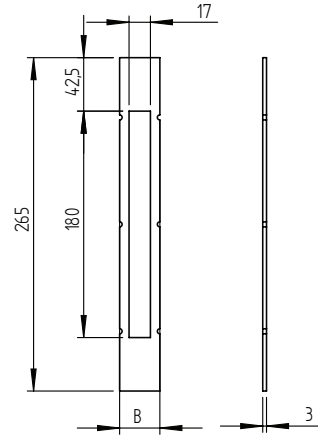

Quality	Finish	art.	B
Fe	raw	B1/34-32A	32
		B1/34-42A	42

B1/34-32A	B1/30-50...	D1/14...	B1/33-30
B1/34-42A			B1/33-40

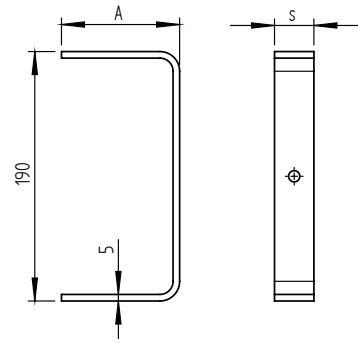
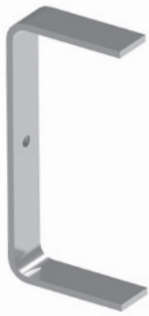

Quality	Finish	art.	A	s
Fe	raw	B1/33-30	90	30
		B1/33-40	85	40

B1/33-30	B1/30-50...	D1/14...	B1/34-32A
B1/33-40			B1/34-42A

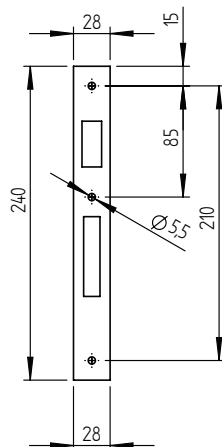

Quality	Finish	art.
Fe	raw	B1/41-28
AISI304	satin	B8/41-28

new

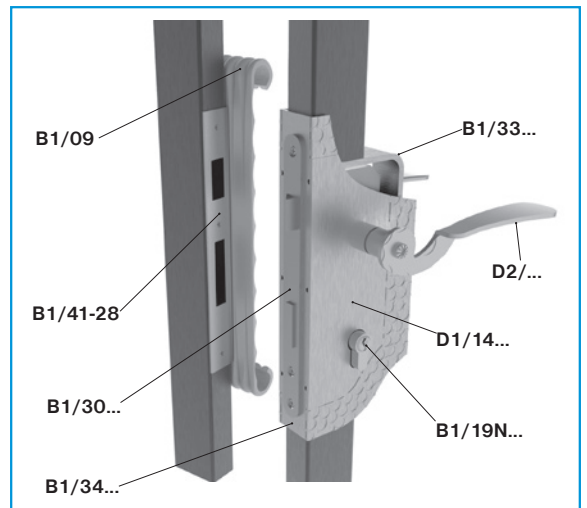

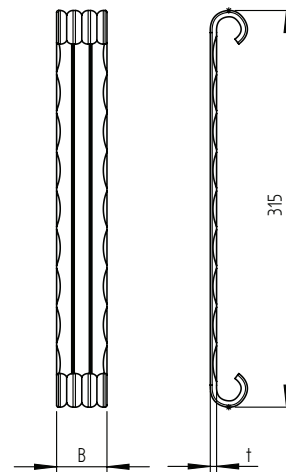
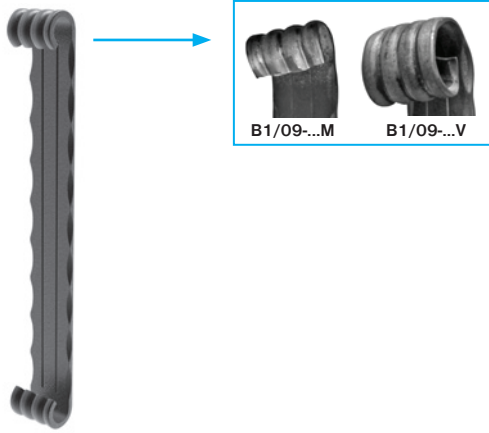

Quality	Finish	art.	B	t
Fe	raw	B1/09-40M	40	5
		B1/09-40V		
		B1/09-50M	50	3
		B1/09-50V		

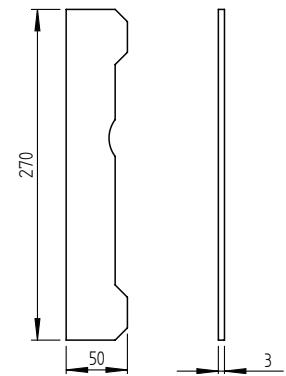

Quality	Finish	art.
Fe	raw	B1/09-50H
AISI304	raw	B8/09-50H



B1/07T...
B8/07T...

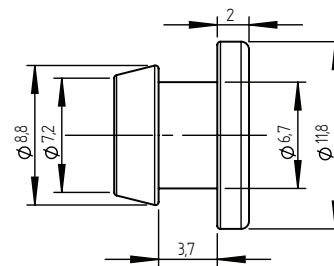

Quality	Finish	art.
Rubber	black	B1/64G

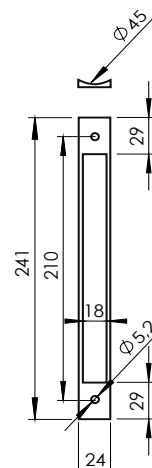

Quality	Finish	art.
PVC	black	B1/65

new





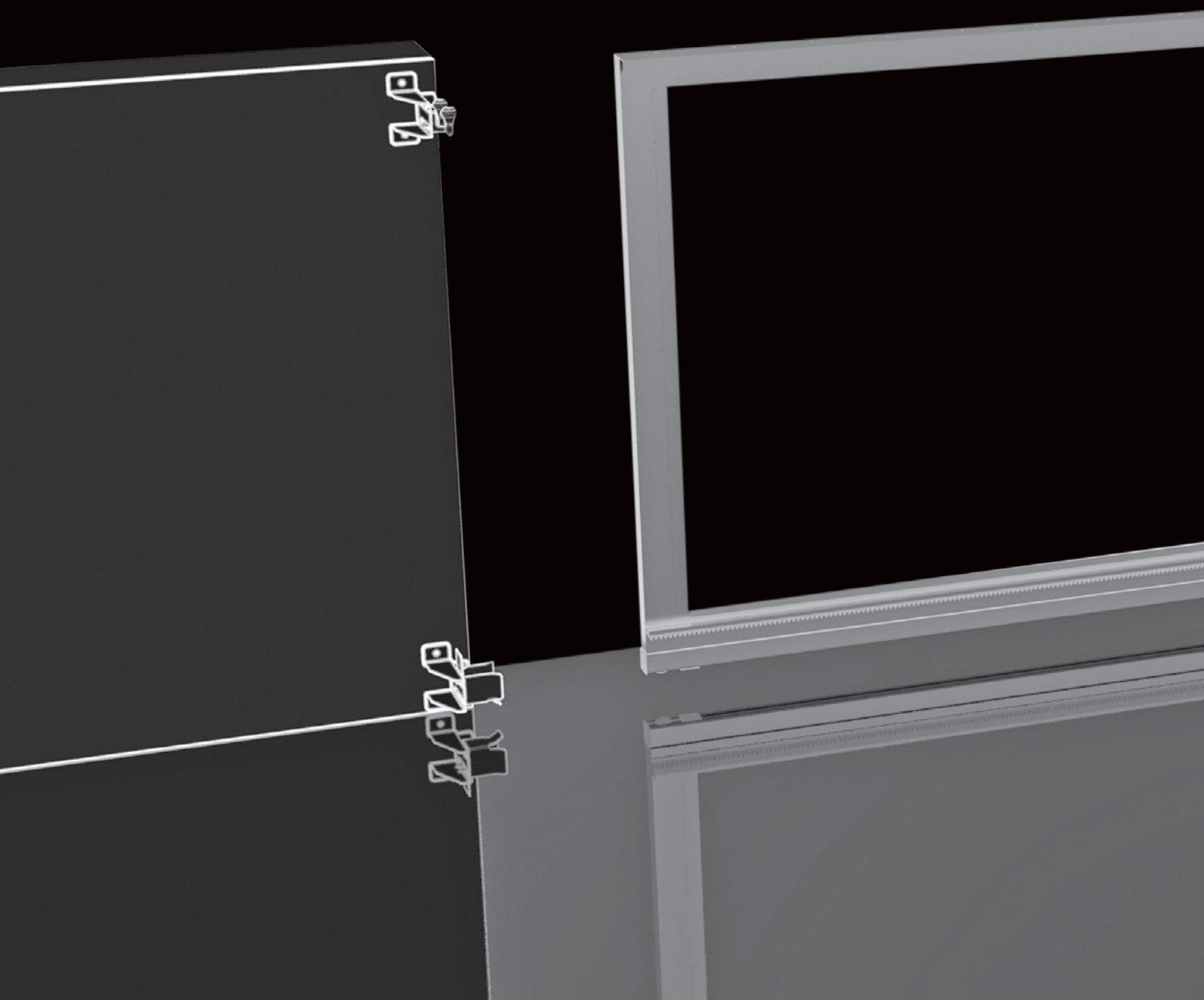

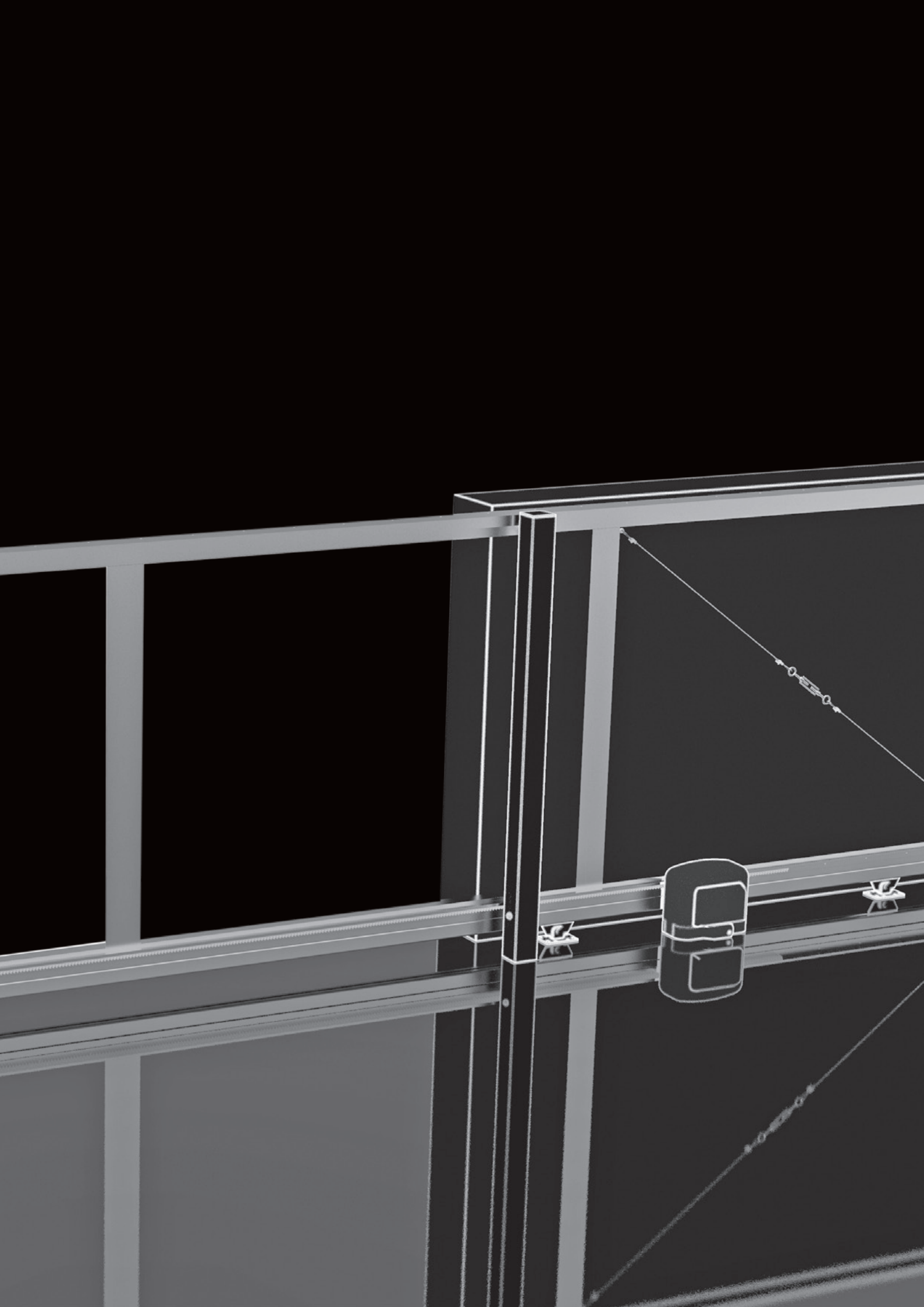
6 • HLINÍKOVÉ BRÁNY ALUMINIUM GATES

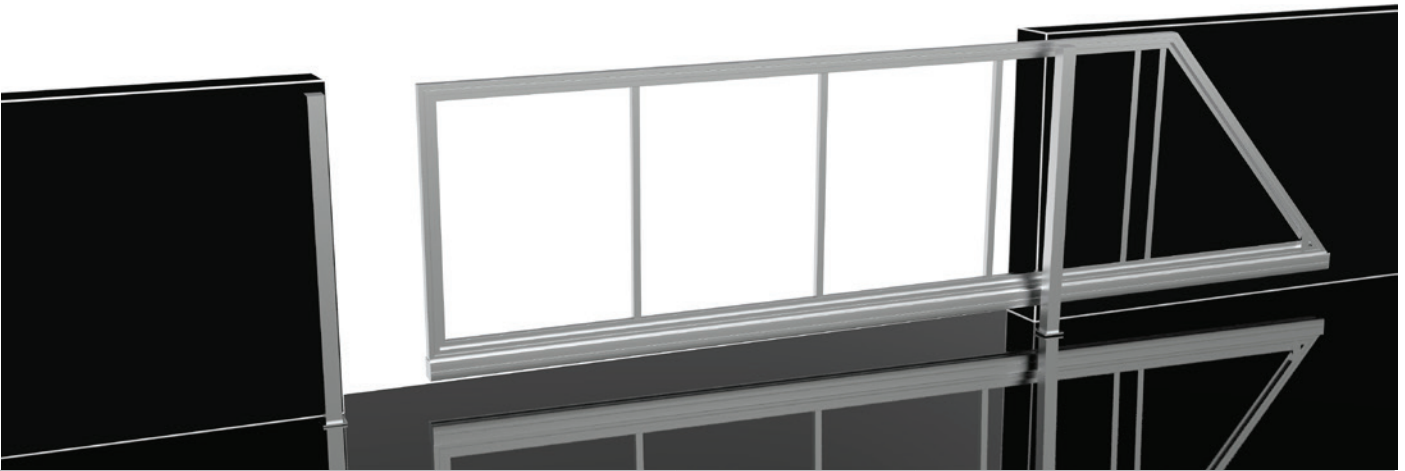
- PRÍSLUŠENSTVO
ACCESSORIES







MODEL AI 90x95 L4m/Gc200kg 					
	H/34-4-90x95-NYLON	H/14N-90x95-NYLON	H/15P-100	H/40-90x95P	H/02-90x95-AL-6000
SV-90x95-AL-ECO	2x	1x	1x	2x	-
SV-90x95-AL	2x	1x	1x	2x	1x

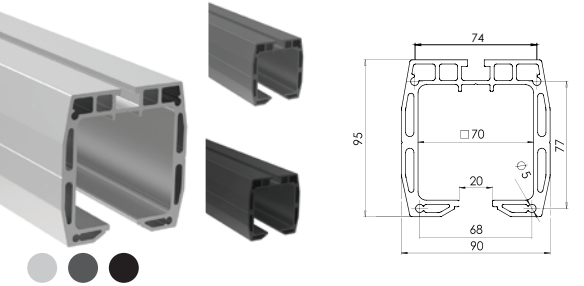

Quality	Finish	art.	Color	L
ALUMINIUM	natural	H/02-90x95-AL-6000	-	6000
		H/02-90x95-AL-BLACK-6000	black	6000
		H/02-90x95-AL-ANTHR-6000	anthracite	6000

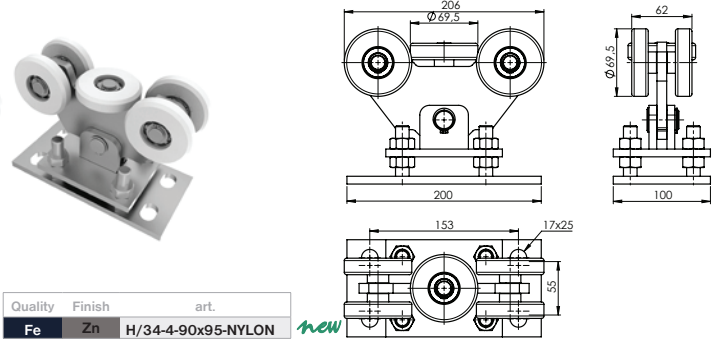

Quality	Finish	art.
Fe	Zn	H/34-4-90x95-NYLON

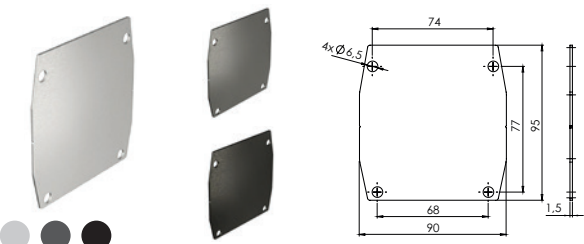

Quality	Finish	art.	Color
Fe	Zn	H/40-90x95P	-
		H/40-90x95P-BLACK	black
		H/40-90x95P-ANTHR	anthracite

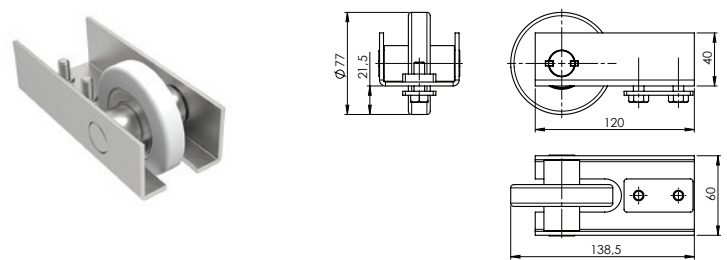



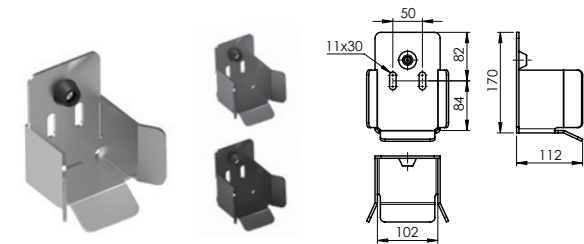

Quality	Finish	art.
Fe	Zn	H/14N-90x95-NYLON



Quality	Finish	art.	Color	A	B	h	s	H
Fe	Zn	H/15P-100	-					
		H/15P-100-BLACK	black	170	108	65	50	108
		H/15P-100-ANTHR	anthracite					
AISI304	raw	H8/15P-100	-					

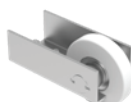

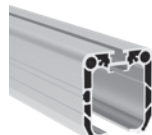
MODEL AI 90x99 L4m/Gc200kg 						
	H/34B-4-90x99-NYLON	H/34B-4G-90x99-NYLON	H8/14N-90x95	H8/15P-100	H8/40-90x99P	H/02-90x99-AL-6000
SV-90x99-AL-ECO	1x	1x	1x	1x	2x	-
SV-90x99-AL	1x	1x	1x	1x	2x	1x

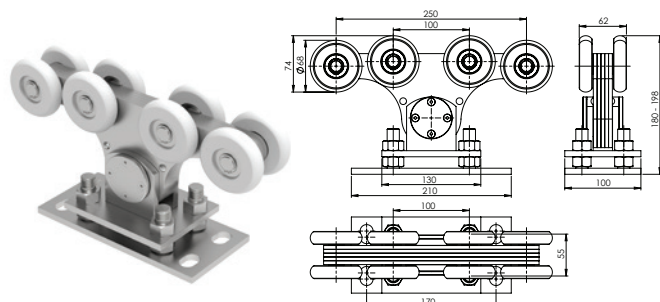

Quality	Finish	art.
Fe	Zn	H/34B-4-90x99-NYLON <i>new</i>

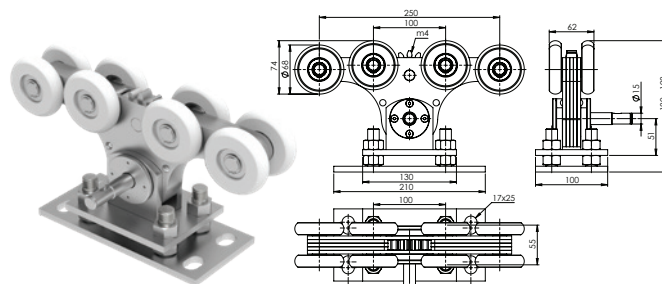

Quality	Finish	art.
Fe	Zn	H/34B-4G-90x99-NYLON <i>new</i>

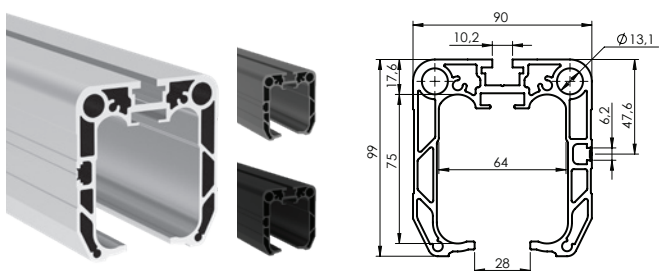

Quality	Finish	art.	Color	L
ALUMINIUM	natural	H/02-90x99-AL-6000	-	<i>new</i>
		H/02-90x99-AL-BLACK-6000	black	6000 <i>new</i>
		H/02-90x99-AL-ANTHR-6000	anthracite	<i>new</i>
		H/02-90x99-AL-7000	-	<i>new</i>
		H/02-90x99-AL-BLACK-7000	black	7000 <i>new</i>
		H/02-90x99-AL-ANTHR-7000	anthracite	<i>new</i>

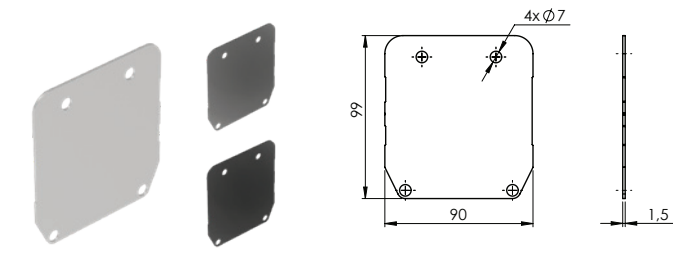

Quality	Finish	art.	Color
ALSI304	raw	H8/40-90x99P	- <i>new</i>
		H8/40-90x99P-BLACK	black <i>new</i>
		H8/40-90x99P-ANTHR	anthracite <i>new</i>

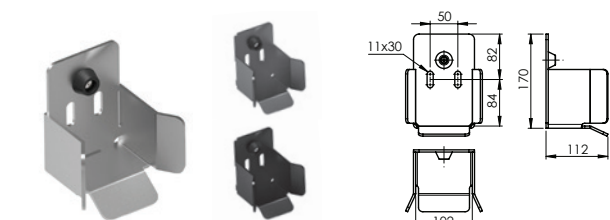

Quality	Finish	art.	Color	A	B	h	s	H
Fe	Zn	H/15P-100	-					
		H/15P-100-BLACK	black	170	108	65	50	108 <i>new</i>
		H/15P-100-ANTHR	anthracite					<i>new</i>
ALSI304	raw	H8/15P-100	-					<i>new</i>

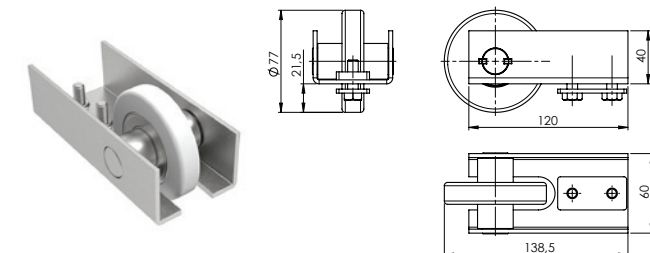

Quality	Finish	art.
ALSI304	raw	H8/14N-90x99-NYLON <i>new</i>

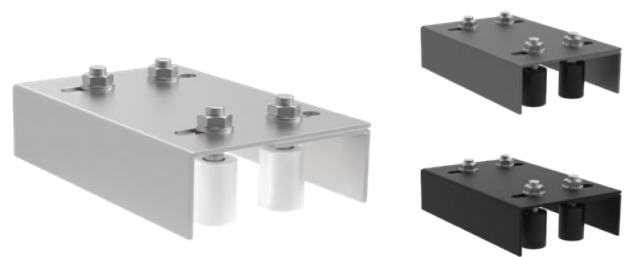
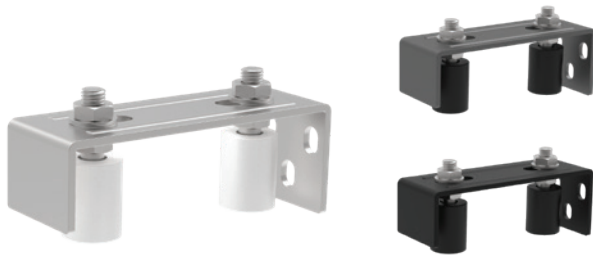

Quality	Finish	art.	Color
Fe	Zn	H/12-2S	-
		H/12-2S-BLACK	black
		H/12-2S-ANTHR	anthracite
AISI304	raw	H8/12-2S	-

*top
new
new*



Quality	Finish	art.	Color
Fe	Zn	H/12-4T	-
		H/12-4T-BLACK	black
		H/12-4T-ANTHR	anthracite
AISI304	raw	H8/12-4T	-

*new
new*

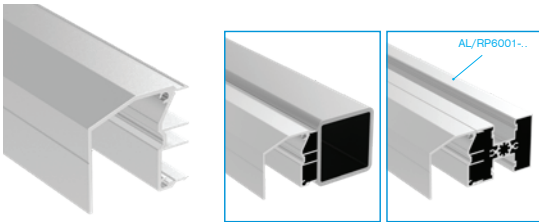

Quality	Finish	art.	
ALUMINIUM	natural	AL/RP-6005-6000-N	H8/04-32-W, H8/04L-35

new

Quality	Finish	art.
Fe	Zn	H/52-40x40
AISI304	raw	H8/52-40x40

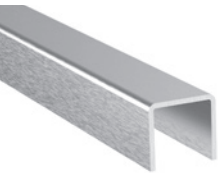

Quality	Finish	art.	b x h	t	L		
AISI304	raw	A/6900-020	28x26	2	2500	H8/04-22-W	
		A/U40x40x3-3M			3000		
		A/U40x40x3-6M			6000		
Fe	Zn	U/40x40x3-3M	40x40	3	3000	H/04-30...	
		U/40x40x3-6M			6000	H/04-32-W	
					6000	H8/04-32-W	
ALUMINIUM	natural	AL/U40x40x3-6M			6000		
AISI304	raw	A/U50x50x3-3M	50x50	3	3000	H/04-42...	
		A/U50x50x3-6M			6000		H/04G-43
		U/50x50x3-3M			3000		H/04L-42
Fe	Zn	U/50x50x3-6M			6000		
ALUMINIUM	natural	AL/U50x50x3-6M			6000		

*new
new*

*new
new
new*

new



Quality	Finish	art.	Color
Fe	Zn	H/53	-
		H/53-BLACK	black
		H/53-ANTHR	anthracite
AISI304	raw	H8/53	-

*top
new
new*



Quality	Finish	art.
AISI304	raw	H8/04-22-W

Quality	Finish	art.
Fe	Zn	H/04G-43
AISI304	raw	H8/04G-43

*top
new*

Quality	Finish	art.
Fe	Zn	H/04L-35
AISI304	raw	H8/04L-35

new

ACCESORIES MIX



Quality	Finish	art.	Color
Fe	Zn	H/37-60P	-
		H/37-60P-BLACK	black
		H/37-60P-ANTHR	anthracite
AISI304	raw	H8/37-60P	-

new

new

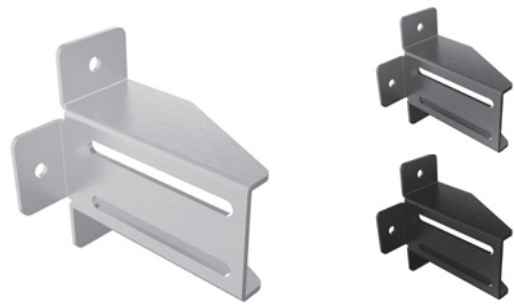

Quality	Finish	art.	Color
Fe	Zn	H/16-46x130	-
		H/16-46x130-BLACK	black
		H/16-46x130-ANTHR	anthracite
AISI304	raw	H8/16-46x130	-

new

new

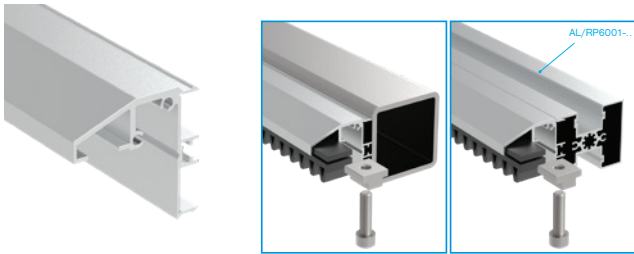

Quality	Finish	art.
ALUMINIUM	natural	AL/RP6004-6000-N

new

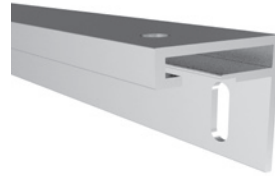

Quality	Finish	art.
ALUMINIUM	natural	H/01PVC-AL-K



Quality	Finish	art.	Color
Fe	Zn	H/10B-60x130	-
		H/10B-60x130-BLACK	black
		H/10B-60x130-ANTHR	anthracite
AISI304	raw	H8/10B-60x130	-

new

new

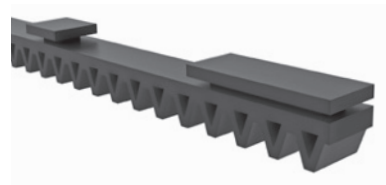

Quality	Finish	art.	Gmax (kg)
NYLON	raw	H/01PVC-AL	300

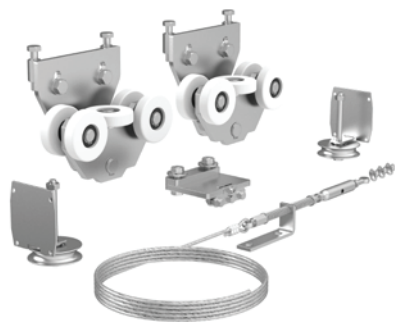

Quality	Finish	art.	max L
Fe	Zn	TS-C2-8-AL	8000

new



art.	G max	G opt
ROAD400-ZKIT	400kg	200kg

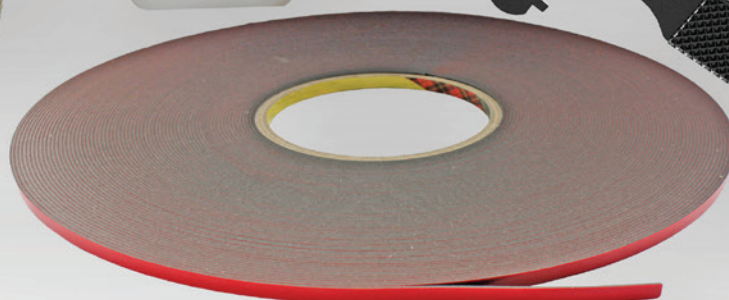



Quality	Finish	art.	M	L
AISI304	raw	A-DIN 914-A2 M5x5		5
		A-DIN 914-A2 M5x6	5	6
		A-DIN 914-A2 M5x8		8
		A-DIN 914-A2 M6x6	6	6
AISI316		A4-DIN 914 M5x5	5	5

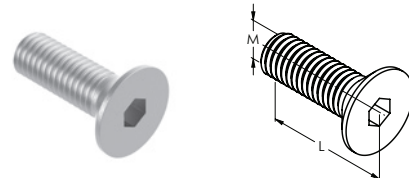

Quality	Finish	art.	M	L
steel 8.8	Zn	DIN 7991 M8x20-Zn	8	20
		DIN 7991 M12x30-Zn	12	30
AISI304	raw	A-DIN 7991-A2 M5x12		12
		A-DIN 7991-A2 M5x16	5	16
		A-DIN 7991-A2 M5x20		20
		A-DIN 7991-A2 M6x8		8
		A-DIN 7991-A2 M6x14		14
		A-DIN 7991-A2 M6x16	6	16
		A-DIN 7991-A2 M6x20		20
		A-DIN 7991-A2 M6x40		40
		A-DIN 7991-A2 M6x60		60
		A-DIN 7991-A2 M8x12		12
		A-DIN 7991-A2 M8x16		16
		A-DIN 7991-A2 M8x30		30
		A-DIN 7991-A2 M8x35	8	35
		A-DIN 7991-A2 M8x50		50
		A-DIN 7991-A2 M8x70		70
		A-DIN 7991-A2 M8x80		80
AISI316	raw	A4-DIN 7991 M5x16	5	16
		A4-DIN 7991 M6x14		14
		A4-DIN 7991 M6x40	6	40
		A4-DIN 7991 M8x20		20
		A4-DIN 7991 M8x30		30
		A4-DIN 7991 M8x70	8	70
		A4-DIN 7991 M8x100		100
		A4-DIN 7991 M10x20	10	20
		A4-DIN 7991 M12x30	12	30



Quality	Finish	art.
AISI304	raw	A-DIN 916-A2 M10x14
AISI316		A4-DIN 916 M10x14

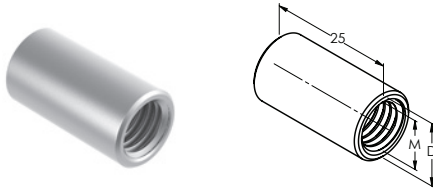

Quality	Finish	art.	M	D
AISI304	raw	A-DIN 6334V M8x25-A2	8	11
		A-DIN 6334V M10x25-A2	10	13

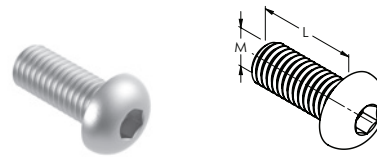

Quality	Finish	art.	M	L
steel 8.8	Zn	DIN 7380 M10x20 8.8-Zn	10	20
AISI304	raw	A-DIN 7380-A2 M5x12	5	12
		A-DIN 7380-A2 M6x12	6	12
		A-DIN 7380-A2 M8x10		10
		A-DIN 7380-A2 M8x12	8	12
		A-DIN 7380-A2 M8x20		20
		A-DIN 7380-A2 M10x20	10	20
AISI316	raw	A4-DIN 7380 M5x12	5	12
		A4-DIN 7380 M5x16		16
		A4-DIN 7380 M6x12	6	12
		A4-DIN 7380 M8x20	8	20
		A4-DIN 7380 M10x20	10	20

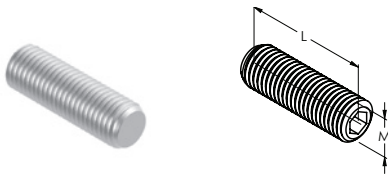

Quality	Finish	art.	M	L
AISI304	raw	A-DIN 913-A2 M5x10	5	10
		A-DIN 913-A2 M6x10		10
		A-DIN 913-A2 M6x12	6	12
		A-DIN 913-A2 M8x16		16
		A-DIN 913-A2 M8x20		20
		A-DIN 913-A2 M8x25		25
		A-DIN 913-A2 M8x30	8	30
		A-DIN 913-A2 M8x40		40
		A-DIN 913-A2 M8x80		80
		A-DIN 913-A2 M10x12		12
		A-DIN 913-A2 M10x35	10	35
		A-DIN 913-A2 M10x100		100
AISI316	raw	A4-DIN 913 M5x5	5	5
		A4-DIN 913 M5x10		10
		A4-DIN 913 M6x10	6	10
		A4-DIN 913 M6x12		12
		A4-DIN 913 M10x12		12
		A4-DIN 913 M10x16	10	16
A4-DIN 913 M10x55		55		

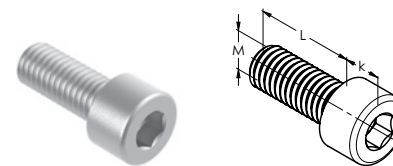

Quality	Finish	art.	M	L	k
AISI304	raw	A-DIN 912-A2 M5x20	5	20	5
		A-DIN 912-A2 M8x20	8	20	8
		A-DIN 912-A2 M10x45	10	45	10
		A-DIN 912-A2 M12x25	12	25	12
AISI316	raw	A-DIN 912-A2 M12x35	12	35	12
		A4-DIN 7984 M8x12	8	12	5

new
new
new

new
new

ACCESSORIES

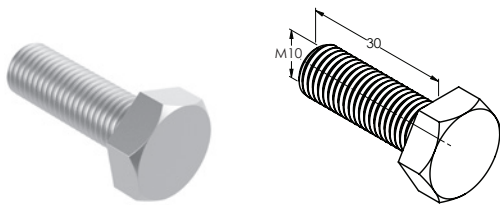

Quality	Finish	art.
steel 8.8	Zn	DIN 933 M10x30 8.8-Zn
AISI316	raw	A4-DIN 933 M10x30

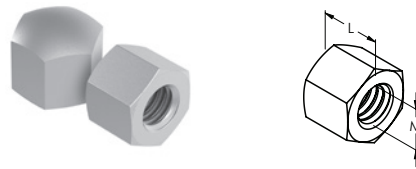

Quality	Finish	art.	M	L
AISI304	raw	A-DIN 917 M8	8	10
		A-DIN 917 M10	10	12

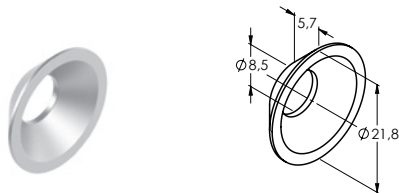

Quality	Finish	art.
AISI316	raw	A14/08-WASHER



Quality	Finish	art.	M	L
AISI304	raw	A-DIN 439B-A2 M8	8	4
		A-DIN 934 M8		6,5
		A-DIN 934 M10	10	8
		A-DIN 934 M12	12	10
		A-DIN 934 M16	16	13
AISI316	raw	A4-DIN 439B M8	8	4
		A4-DIN 934 M10	10	8

new

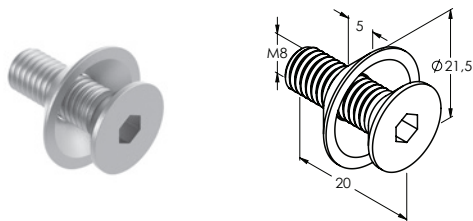

Quality	Finish	art.
steel 8.8	Zn	W-DIN 7991 M8x20-P
AISI316	raw	W-DIN 7991-A4 M8x20-P

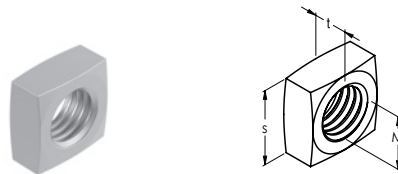

Quality	Finish	art.	M	s	t
AISI304	raw	A-DIN 562 M6	6	10	3,2
		A-DIN 562 M8	8	13	4
		A-DIN 562 M10	10	17	5

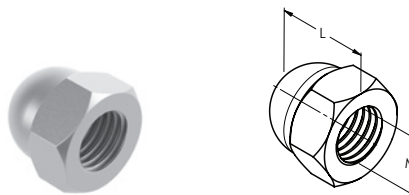

Quality	Finish	art.	D	d	t
steel	Zn	DIN 125 10-Zn	20	10	2
		DIN 9021 10-Zn	30		2,5
		WIT-SHB M8-Zn	23	9	5
		WIT-SHB M10-Zn	26	12	
		WIT-SHB M12-Zn	28	14	
AISI304	raw	A-DIN 125-A2 M5	10	5	1
		A-DIN 9021-A2 M8	30	8	2,5
		A-DIN 125-A2 M8	16	8	1,6
		A-DIN 125-A2 M10	20	10	2
		A-DIN 125-A2 M12	24	12	2,5
		A-DIN 433-A2 M12	20	12	2
		A4-DIN 9021 M8	24	8,4	2
		A4-DIN 9021 M16	50	17	2,5
		A4-WIT-SHB M8	23	9	5
		A4-WIT-SHB M10	26	12	
A4-WIT-SHB M12	28	14			

new

new

new

Quality	Finish	art.	M	L
AISI304	raw	A-DIN 1587-A2 M6	6	12
		A-DIN 1587-A2 M8	8	15
		A-DIN 1587-A2 M10	10	18
		A-DIN 1587-A2 M12	12	22
AISI316	raw	A4-DIN 1587 M10	10	18

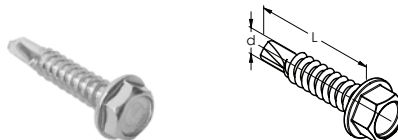

Quality	Finish	art.	d	L
AISI304	raw	A-DIN 7504K 5,5x25	5,5	25

new



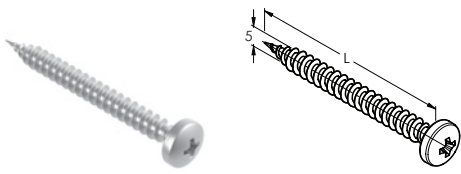

Quality	Finish	art.9	L
AISI304	raw	A-PH 5x20	20
		A-PH 5x35	35

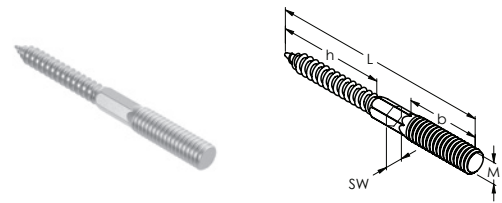

Quality	Finish	art.	M	L	b	h	SW
AISI304	raw	A-DIN 9210 M6x60-A2	6	60	20	37	-
		A-DIN 9210 M8x60-A2	8	100	42	48	✓
		A-DIN 9210 M10x100-A2	10	100	30	57	✓
AISI316	raw	A4-DIN 9210 M6x100	6	100	-	-	✓
		A4-DIN 9210 M8x60	8	60	20	37	-
		A4-DIN 9210 M8x100	8	100	42	48	✓



Quality	Finish	art.	L
AISI304	raw	A-DIN 7505A 5x20	20
		A-DIN 7505A 5x35	35

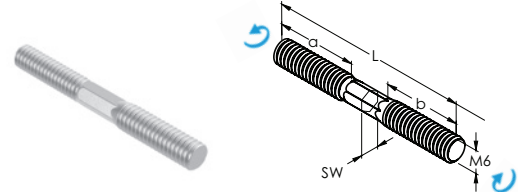

Quality	Finish	art.	M	L	a	b	SW
AISI316	raw	A4-DUAL M6/M6	6	65	30	30	✓
		A4-DUAL M10/M10	10	-	-	-	✓

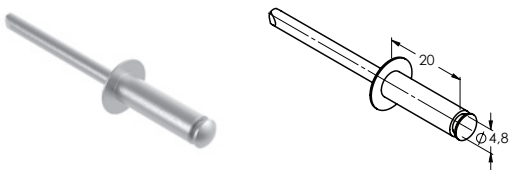

Quality	Finish	art.
AISI304	raw	A-DIN 7337-A2 4,8x20

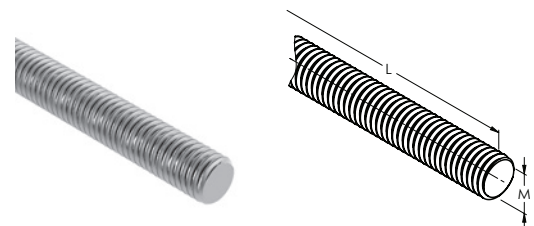

Quality	Finish	art.	M	L	ETA opt.1
steel 8.8	Zn	Q5/08-VM250-M10-...	10	-	✓
		Q5/08-VM250-M12-...	12	-	✓
AISI304	raw	A-DIN 975 M6	6	-	-
		A-DIN 975 M8	8	-	-
		A-DIN 975 M10	10	1000	-
		A-DIN 975 M12	12	-	-
		A-DIN 975 M16	16	-	-
AISI316	raw	A4-DIN 975 M10	10	-	-
		A5/08-VM250-M10-...-A4	10	-	✓
AISI304	raw	A5/08-VM250-M12-...-A4	12	-	✓
		A-DIN 975 M8-100	-	100	-
		A-DIN 975 M8-120	-	120	-
		A-DIN 975 M8-150	-	150	-
		A-DIN 975 M8-200	-	200	-
		A-DIN 975 M10-100	-	100	-
		A-DIN 975 M10-120	-	120	-
		A-DIN 975 M10-150	-	150	-
		A-DIN 975 M10-200	-	200	-
		A-DIN 975 M12-100	-	100	-
		A-DIN 975 M12-120	-	120	-
		A-DIN 975 M12-150	-	150	-
A-DIN 975 M12-200	-	200	-		



Quality	Finish	art.	M	L
AISI304	raw	A-FTT-M5	5	12
		A-FTT-M6	6	14
		A-FTT-M8	8	16,5
		A-FTT-M10	10	19



Quality	Finish	art.	M
steel	Zn	WOOD/M8-D	8
		WOOD/M10-D	10

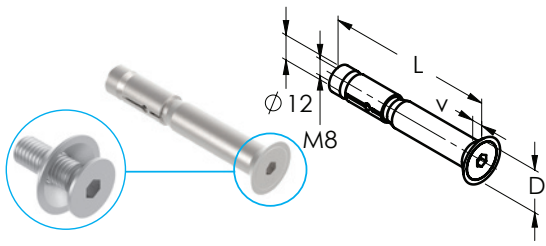

Quality	Finish	art.	L	D/v
steel	Zn	Q5/08-HAZ-M8-80SK/S	80	20,5/5
		Q5/08-FH12-50	125	22/5,8
		Q5/08-12-125		
AISI316	raw	A5/08-HAZ-M8-80SK/A4	80	20,5/5
		A5/08-12-125	125	22/5,8

top
new
new

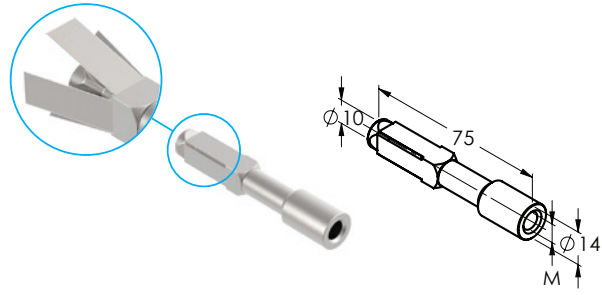

Quality	Finish	art.	M
steel	raw	Q11/FPX-M8	8
		Q11/FPX-M10	10

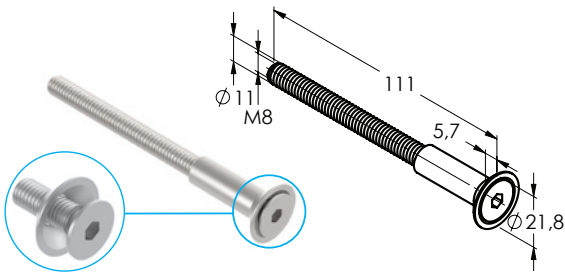

Quality	Finish	art.
AISI304	raw	A5/08-105x11xM8
AISI316		A14/08-105x11xM8

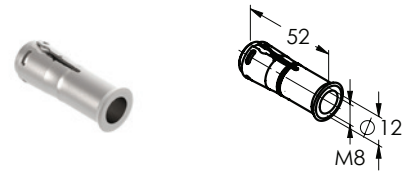

Quality	Finish	art.
steel	Zn	Q5/08-TNTR08-8x52

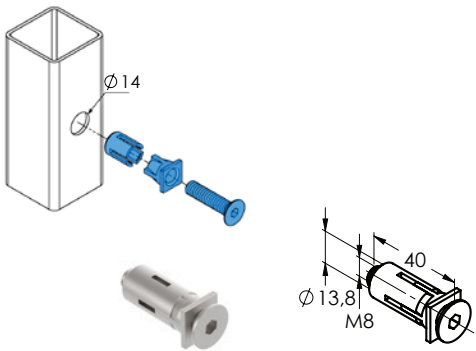

Quality	Finish	art.
steel	Zn	Q5/09-Quick-Fix QF5

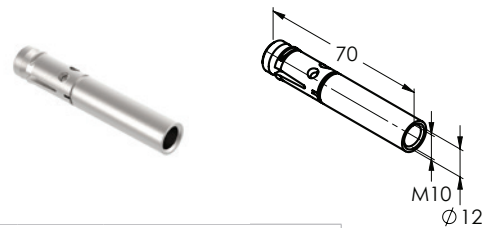

Quality	Finish	art.
steel	Zn	Q5/08-FAZ-IG-M10-70/S
AISI316	raw	A5/08-FAZ-IG-M10-70/A4



A19/04-PVC A19/04-PVC-L A19/04-PVC-BLACK

Quality	Finish	art.
PVC	raw	A19/04-PVC
	polish	A19/04-PVC-L
	black	A19/04-PVC-BLACK

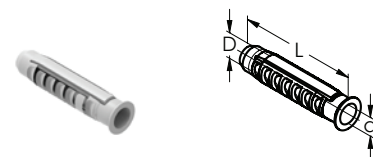

Quality	Finish	art.	D	d	L
NYLON	gray	Q5/07-8 NYLON	8	2,5-4	40
		Q5/07-10 NYLON	10	3-6	50
		Q5/07-12 NYLON	12	4-8	60

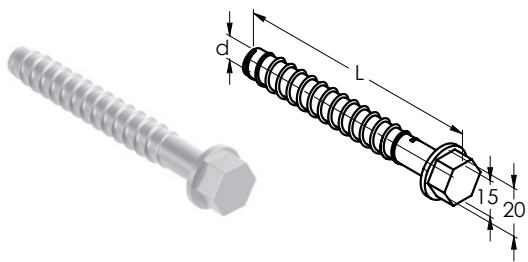

Quality	Finish	art.	d	L
steel 5.8	Zn	Q5/08-BS-S-10-90/S	10	90
AISI316	raw	A5/08-BS-S-10-90/A4		
steel 5.8	Zn	Q5/08-BS-S-12-110/S	12	110
AISI316	raw	A5/08-BS-S-12-110/A4		

new

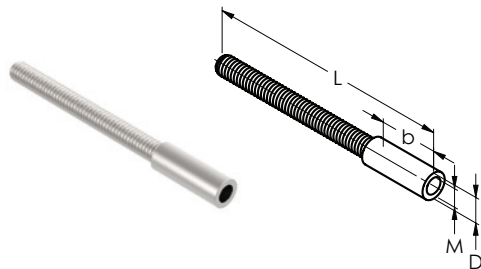

Quality	Finish	art.	M	L	D	b
AISI304	raw	A19/27-M8	8	11	15	15
		A19/27-M10	10	13		
		A19/27-M12	12	15		

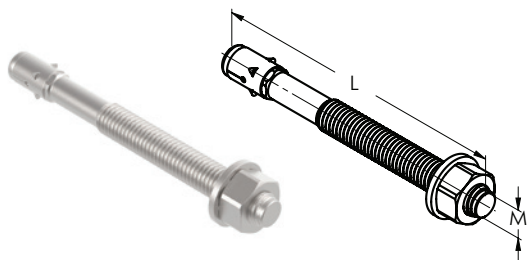

Quality	Finish	art.	M	L
steel	Zn	Q5/06-8x100CE	8	92
		Q5/06-10x120CE	10	120
	raw	Q5/08-FBN12-30	12	126
	Zn	Q5/06-16x123CE	16	123
		Q5/06-16x138CE	16	138
AISI304	raw	A-Q5/06-10x120CE	10	120

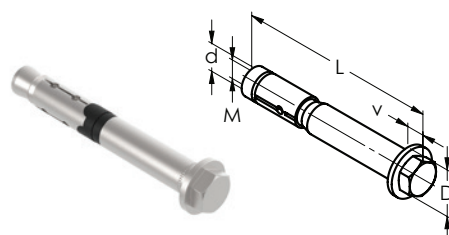

Quality	Finish	art.	M	L	d	D/v
steel	Zn	Q5/08-HAZ-M8-85S/S	8	85	12	20/7,5
	raw	Q5/08-FH15/25 S	10	89	15	25/9,5
		Q5/08-HAZ-M10-106S/S		106	15	25/9,5
AISI316	raw	A5/08-HAZ-M8-85S/A4	8	85	12	20/7,5
		A5/08-HAZ-M10-106S/A4	10	106	15	25/9,5

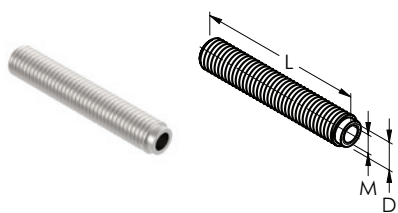

Quality	Finish	art.	M	L	D
steel 5.8	Zn	Q5/08-VHG-M8-100/S	8	100	12
		Q5/08-VHG-M10-80/S	10	80	16
		Q5/08-VHG-M12-125/S	12	125	20
AISI316	raw	A5/08-VHG-M8-100/A4	8	100	12
		A5/08-VHG-M10-80/A4	10	80	16
		A5/08-VHG-M12-125/A4	12	125	20



Quality	Finish	art.
PVC	raw	A12/12-PVC
		A12/12-35-PVC

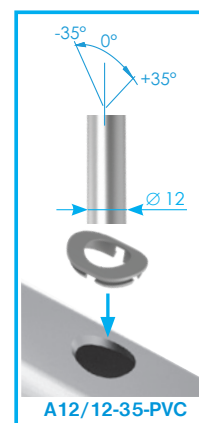



art.	ml	quality	description
Q5/01GF-300 Nordic			-20°C +10°C
Q5/01GF-400 Nordic		vinylester	
Q5/01GF-300			-10°C +30°C
Q5/01GF-400			

top



art.	ml	quality	description
Q5/01B-300			-10°C +40°C
Q5/01B-400		vinylester	-10°C +40°C
Q5/01B-400 Winter			-20°C +20°C

new



art.	ml	quality	description
Q5/01GFP-300			
Q5/01GFP-400		Polyester	-5°C +30°C



art.	ml	quality	description
Q5/05TR-310		Silicone	-5°C +40°C



art.	ml	quality	description
Q5/01-WIT-UH300...	320	uretan vinylester	-5°C +40°C
Q5/01-WIT-VM250...	300	vinylester	-10°C +40°C



Q5/04-250

art.	M	L
Q5/04	17	215
Q5/04-250	8	250

new



art.	description
Q5/03-300	300ml, hobby



art.	description
Q5/03-400	400ml, profi



art.	description
Q5/01-16x130	mesh

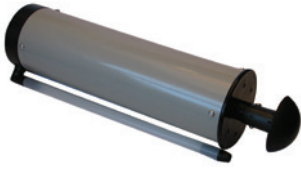

art.	description
Q5/02	blow pump



art.	t	b	L
Q9/03-3x12	3	12	16,5

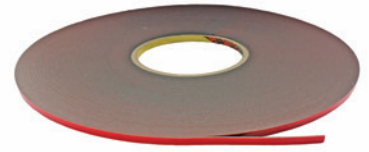

art.	t	b	L
Q9/03-0,2x9	0,2	9	50
Q9/03-0,5x9	0,5	9	33
Q9/03-2x6	2	6	16,5

new



art.	∅	description
Q1/B02-INOX	3-45	Pipe cutting

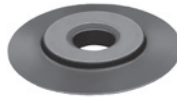

art.	compatibility
Q1/B02-INOX-RK	Q1/B02-INOX

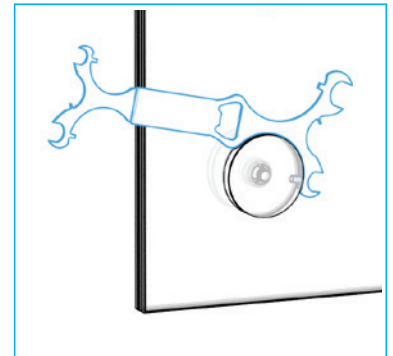
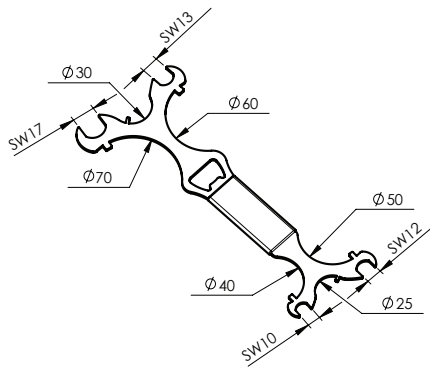

Quality	Finish	art.
AISI304	raw	A19/model741-8

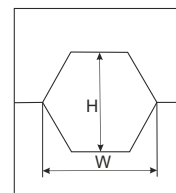

art.	Mould size	W	H
Q8/95	4	4	3
	6	5	3,5
	8	6	4,5
	10	6,5	5,4
	16	7,3	6,4
	25	9	7,4
	35	11	9,2
	50	13	10,8
70	15	12,6	



new

art.	description	operation
Q8/LP-7x4,5	riveting punch	2 steps



new

art.	description	operation
Q8/LP-7x4,5-B	riveting punch	1 step

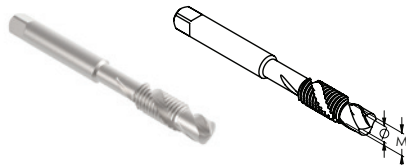
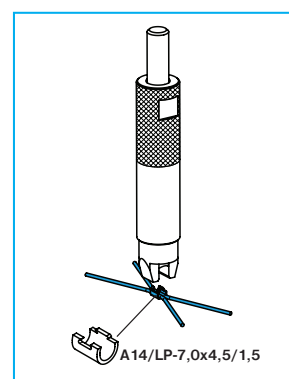

Quality	art.	M	Ø
HSS-C05	A-DRILL-M5	5	4
	A-DRILL-M6	6	4,8
	A-DRILL-M8	8	6,4

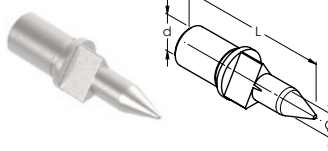

Quality	art.	M
HSSE	A/FDRILL-M5C	5
	A/FDRILL-M6C	6
	A/FDRILL-M8C	8
	A/FDRILL-M10C	10

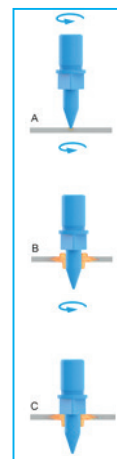

new

art.	description	ml
J08/08	cutting/drilling oil	400



art.	description
Q1/RN01-125x1	cutting disc
Q1/RN01-150x1,6	
Q1/RN01-230x2	

top new



art.	description
Q1/L01-125-40	flap disc
Q1/L01-125-60	
Q1/L01-125-80	
Q1/L01-125-120	

new

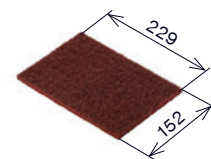

art.	granularity
Q1/G01	360



Q/INOX-INSTALL-SET



Q/INOX-INSTALL-SET-B

new

art.								
Q/INOX-INSTALL-SET	1x	-	-	1x	1x	1x	1x	1x
Q/INOX-INSTALL-SET-B	-	1x	1x	2x	2x	1x	1x	2x



art.	g	gap	description
A/Glue-10g-C	10	0,2	INOX



art.	g	gap	description
A/Glue-20g	20	0,2	all purpose superfast



art.	g	gap	description
A/GLUE-50g-C	50	0,2	INOX
A/GLUE-50g-D		0,4	INOX



new

art.	ml	description
Q5/05-MAMUT	290	instant fix



new

art.	ml
GS/Cleaner-Glass	200



new

art.	ml
GS/Cleaner-Metal	200



A/ACTIVATOR



CA/ACTIVATOR



CA/LAK

art.	g	description
A/ACTIVATOR-50g	50	for A/Glue..
CA/ACTIVATOR	1000	corten effect
CA/LAK		lacquer for corten

*new
new
new*



art.	ml	description
A/spray-WS	400	INOX

top



art.	ml	description
A/Cleaner-500ml	500	INOX



ACCESSORIES



Art.
kat-Forged-2024/25

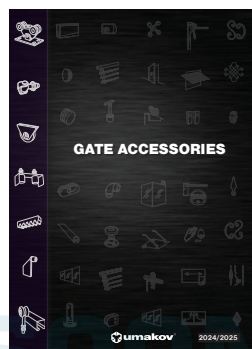

Art.
kat-Gates-2024/25



Art.
kat-Automations-2023/24



Art.
KAT-ALU-SYSTEMS-2024/25



Art.
KAT-GLASS RAILINGS-2024/25



Art.
KAT-POST RAILINGS-2024/25

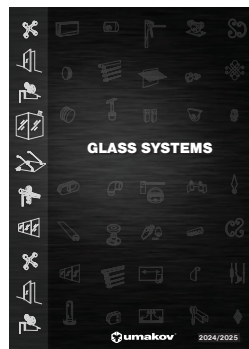

Art.
KAT-GLASS SYSTEMS-2024/25

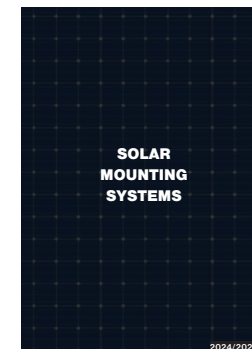

Art.
KAT-SOLAR-SYSTEMS-2024/25

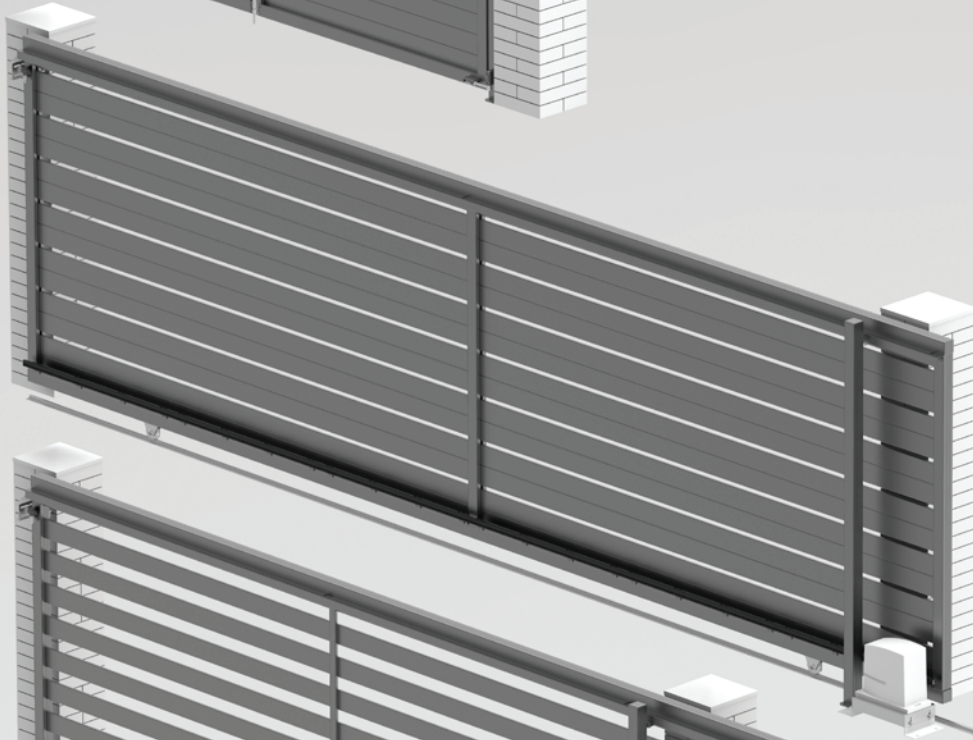
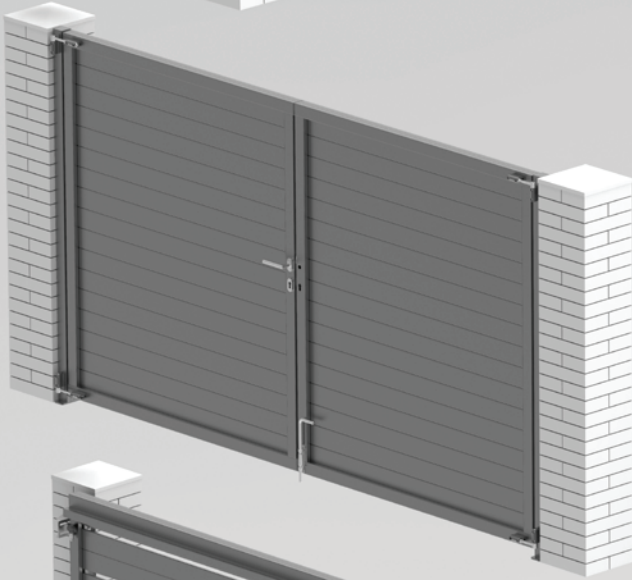
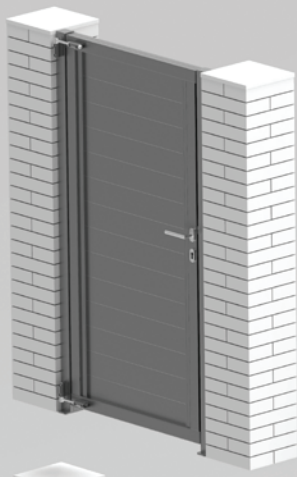

ALUMINUM fence systems

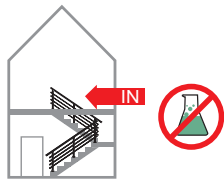

INOX			ALUMINIUM	ZAMAK
AISI304	AISI316	S.S. 2205	✓	✓

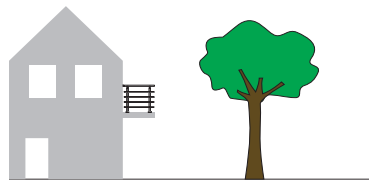

INOX			ALUMINIUM	ZAMAK
✓	✓	✓	✓	✗

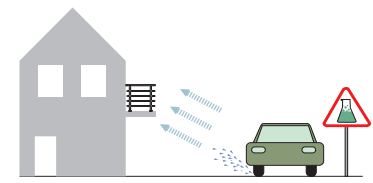

INOX			ALUMINIUM	ZAMAK
✗	✓	✓	✓	✗



INOX			ALUMINIUM	ZAMAK
✗	✓	✓	✓	✗

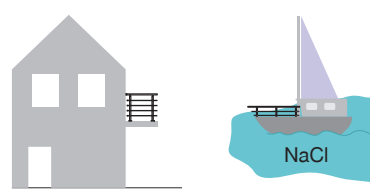

INOX			ALUMINIUM	ZAMAK
✗	✓	✓	✓	✗



INOX			ALUMINIUM	ZAMAK
✗	✗	✓	✗	✗

* only mirror finish (polished)

material						
AISI304	nerezová oceľ	stal nierdzewna	rozsdamentes acél	stainless steel	Edelstahl	INOX
AISI316						
S.S. 2205						
CORTEN	corten oceľ	corten stal	corten acél	corten steel	Cortenstahl	corten
ALUMINIUM	hliník	aluminium	aluminium	aluminium	Aluminium	aluminium
ZAMAK	zliatina Zn+Al	stop cynku i aluminium	Zn+Al ötvözet	ZAMAC	Zinkdruckguss	alliage Zn+Al
Fe	železo	želazo	vas	iron	Eisen	fer
Zn	zinok	cynk	cink	zinc	Zink	zinc
Brass	mosadz	miedź	sárgaréz	brass	Messing	laiton
PVC	polyvinyl chloride					
PETG	polyethylene terephthalate glycol					
Rubber	guma	guma	gumi	rubber	Gummi	gomme
Beech	buk	buk	bükk	beech	Buche	hêtre
Oak	dub	dąb	tölgy	oak	Eiche	chêne
Spruce	smrek	świerk	lucfenyő	spruce	Fichte	épicéa
VSG/ESG	sklo	szklo	üveg	glass	Glas	verre
finish/effect						
satín	brus K320	szlif K320	szálciszolt K320	brushed K320	geschliffen K320	brossé K320
silver	strieborný	srebro	ezüst	silver	Silber	argent
polish	lesk	polerowany	tükör polírozott	polished	poliert	poli
raw	surový	surowy	nyers	raw	roh	brossé
natural	nebrúsený	nezliffovaný	natúr	rough	ungeschliffen	non-brossé
INOX	nerez	nierdzewny	rozsdamentes	inox	Edelstahl	inox
ELOX	eloxovaný	anodowany	eloxált	elox	Eloxiert	anodisé
	potrebné úpravy	niezbędne przystosowanie	szükséges módosítás	necessary modification	Anpassung ist notwendig	modification nécessaire
	nezmontované	niezłożone	nem összeszerelt	not assembled	unmontiert	non assemblé
≈	približný rozmer	przybliżone wymiary	közeltő méretek	approximate dimension	die Abmessungen sind ungefähr	dimensions approximatives
top new	bestseller	bestseller	legjobban eladott	best seller	Bestseller	best-seller
	novinka	nowość	új	new	Neuheit	nouveau
	RAL color					
	PVD = (physical vapor deposition) coating PVD-L = polished surface finish					
	LED					

- INOX AISI 304**
- vhodný do prostredia bez chlóru a oxidu siričitého
INOX AISI 316
- vhodný do prostredia s vysokým obsahom chlóru, oxidu siričitého, vysokej vlhkosti, do prímorských regiónov
INOX S.S. 2205 - vhodný do prostredia s vysokým obsahom chlóru, oxidu siričitého, vysokej vlhkosti s prítomnosťou soli na pobreží a na voľnom mori.
- INOX AISI 304**
- suitable for the environment without chlorine and sulphur dioxide load
INOX AISI 316
- suitable for the environment with a high content of chlorine, sulphur dioxide load, high humidity, coastal regions
INOX S.S. 2205
- Suitable for environments with a high content of chlorine, sulfur dioxide, high humidity with salt on the coast and on the high seas.
- INOX AISI 304**
- przeznaczone dla środowiska bez dwutlenku siarki oraz chloru
INOX AISI 316
- przeznaczone dla środowiska o wysokiej zawartości dwutlenku siarki oraz chloru, wysokiej wilgotności oraz w regionach nadmorskich
INOX S.S. 2205
- Nadaje się do środowisk o wysokiej zawartości chloru, dwutlenku siarki, o wysokiej wilgotności, o dużym zasoleniu, w strefach nadmorskich, lub w bezpośrednim kontakcie z wodą morską.
- INOX AISI 304**
- alkalmazható olyan környezetben, ahol nincs klór és kén-dioxid terhelés
INOX AISI 316
- alkalmazható olyan környezetben, ahol magas a klór-, vagy kén-dioxid terhelés, magas a páratartalom, tengerparti régiókban
INOX S.S. 2205
- „Alkalmazható magas klór-, kén-dioxid-, sós nedvességtartalmú környezetben, valamint tengerparton és a nyílt tengeren”.
- INOX AISI 304**
- geeignet in Umgebung ohne Chlor und Schwefeldioxid
INOX AISI 316
- geeignet in Umgebung mit einem hohen Gehalt an Chlor, Schwefeldioxid oder in Umgebung mit hoher Luftfeuchtigkeit, in Küstenregionen
INOX S.S. 2205
- geeignet für Umgebungen mit hohem Gehalt an Chlor, Schwefeldioxid und hoher Luftfeuchtigkeit mit Salz an der Küste und auf hoher See
- INOX AISI 304**
- Convenable pour les environnements sans chlore et/ ou bioxyde de soufre
INOX AISI 316
- Convenable pour les environnements avec un contenu élevé de chlore et/ ou de bioxyde de soufre, une grande humidité, régions maritimes
INOX S.S. 2205
- Convenable au milieu avec un contenu élevé du dioxyde de soufre, ainsi qu'au milieu humide contenant du sel, tel que le bord de mer ou la mer ouverte.

TEST / CERTIFICATE						
				STATIC STUDIO		
					TESTED BY RISE SWEDEN	

právo na technické, tvarové a rozmerové zmeny vyhradené / rights to technical, shape and dimensional changes reserved
pre najnovšie informácie navštívte našu webovú stránku www.umakov.sk / for latest information please visit our web site www.umakovshop.com

umakov.sk





 +421 51 488 19 00
info@umakov.sk

 umakov.sk
objednavky@umakov.sk

 +421 908 944 153
+421 910 262 707
+421 908 986 081

 **SERVIS**
+421 910 262 820
+421 911 383 645
servis@umakov.sk

 **REKLAMÁCIE**
+421 911 915 952
reklamacie@umakov.sk

 **ÚČTOVNÉ ODDELENIE**
+421 902 928 245
+421 911 750 326
fakturacia@umakov.sk

 **MARKETING**
+421 915 781 139
marketing@umakov.sk

 **KROMPACHY**
Hornádska 337
053 42

 **BRATISLAVA**
Rožňavská 1
831 04

 **BANSKÁ BYSTRICA**
Zvolenská cesta 17
974 05

 +421 911 455 347
krompachy@umakov.sk

 +421 917 739 412
+421 904 644 378
ba@umakov.sk

 +421 905 304 548
bb@umakov.sk

umakov.cz





 +420 212 240 751
info@umakov.cz

 umakov.cz
objednavky@umakov.cz

 +420 608 743 164
+420 775 455 079
+420 608 313 799

 **SERVIS**
+420 775 061 735
+421 910 262 820

 **REKLAMACE**
+421 911 915 952

 **ÚČETNÍ ODDELENÍ**
+421 902 928 245
+421 911 750 326

servis@umakov.cz

reklamace@umakov.cz

fakturace@umakov.cz

 **PRAHA - OTICE**
Otice 40
251 63 Strančice

 **ŘÍČANY U BRNA**
Nám. Osvobození 63
664 82

 **HRADEC KRÁLOVÉ**
Náchodská 607
503 01

 +420 608 313 799
praha@umakov.cz

 +420 608 743 164
brno@umakov.cz

 +420 778 001 899
hk@umakov.cz

umakov.pl





 +48 32 202 19 29
info@umakov.pl

 umakov.pl
zamowienie@umakov.pl

 +48 500 110 199
+48 668 494 940
+48 517 534 197

 **GDAŃSK**
+48 735 419 155
gdansk@umakov.pl

 **RADOM**
+48 664 855 695
radom@umakov.pl

 **NOWY SACZ**
+48 510 696 236
nowysacz@umakov.pl

 **POZNAŃ**
+48 602 335 611
poznan@umakov.pl

 **Ruda Śląska**
Al. Rodziny Gurtlerów 81
41-700

 +48 517 534 197
umakov@umakov.pl

umakov.hu



 +36 306 446 653
info@umakov.hu

 umakov.hu
megrendeles@umakov.hu

 +36 306 446 653
+36 301 610 011
+36 307 572 009

 **BUDAPEST**
Kármán Tódor utca 1. A. ép. 1. ajtó
2142 Nagytarcsa

 +36 305 662 474
hungary@umakov.hu



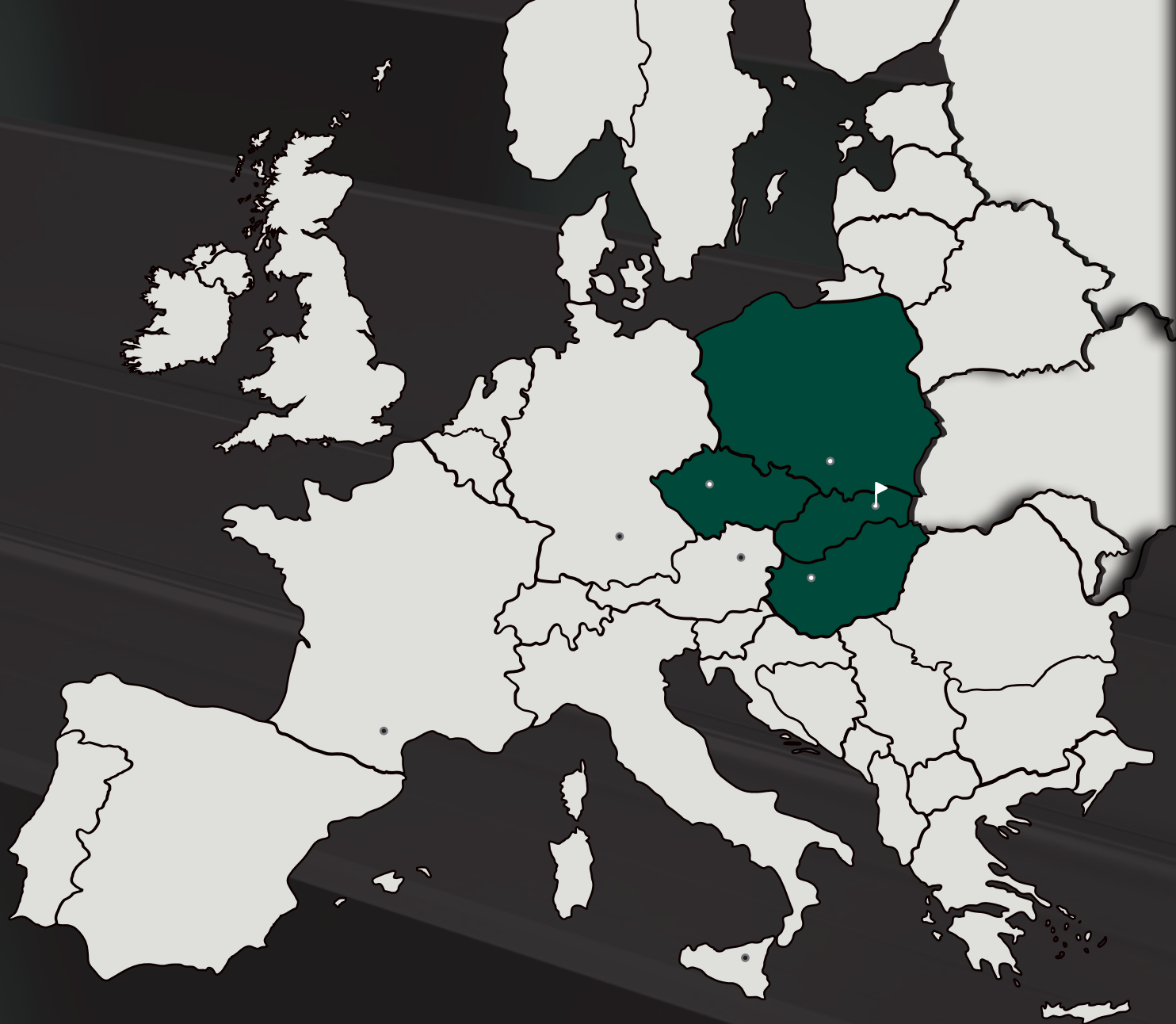

▶ UMAKOV SK

www.umakov.sk
info@umakov.sk

+421 51 488 19 00

▶ UMAKOV CZ

www.umakov.cz
info@umakov.cz

+420 212 240 751

▶ UMAKOV PL

www.umakov.pl
info@umakov.pl

+48 32 202 19 29

▶ UMAKOV HU

www.umakov.hu
info@umakov.hu

+36 306 446 653

👤 UMAKOV DE / AT

www.umakov.de
info@umakov.de

+421 907 684 761

👤 UMAKOV FR

www.umakov.fr
info@umakov.fr

+33 6.46.33.03.51

👤 UMAKOV IT

www.umakov.it
info@umakov.it

+39 348 349 0444

👤 UMAKOV WORLD

www.umakovshop.com
info@umakovshop.com

+421 915 093 533